

# Water Treatment System Diagram

August 1, 2011  
Tokyo Electric Power Company

Desalination facilities

Added device

➡ Cesium absorption  
➡ Coagulation settling

The flow of the process can be changed from Coagulation settling to Cesium absorption by valve operation.

Reactor building

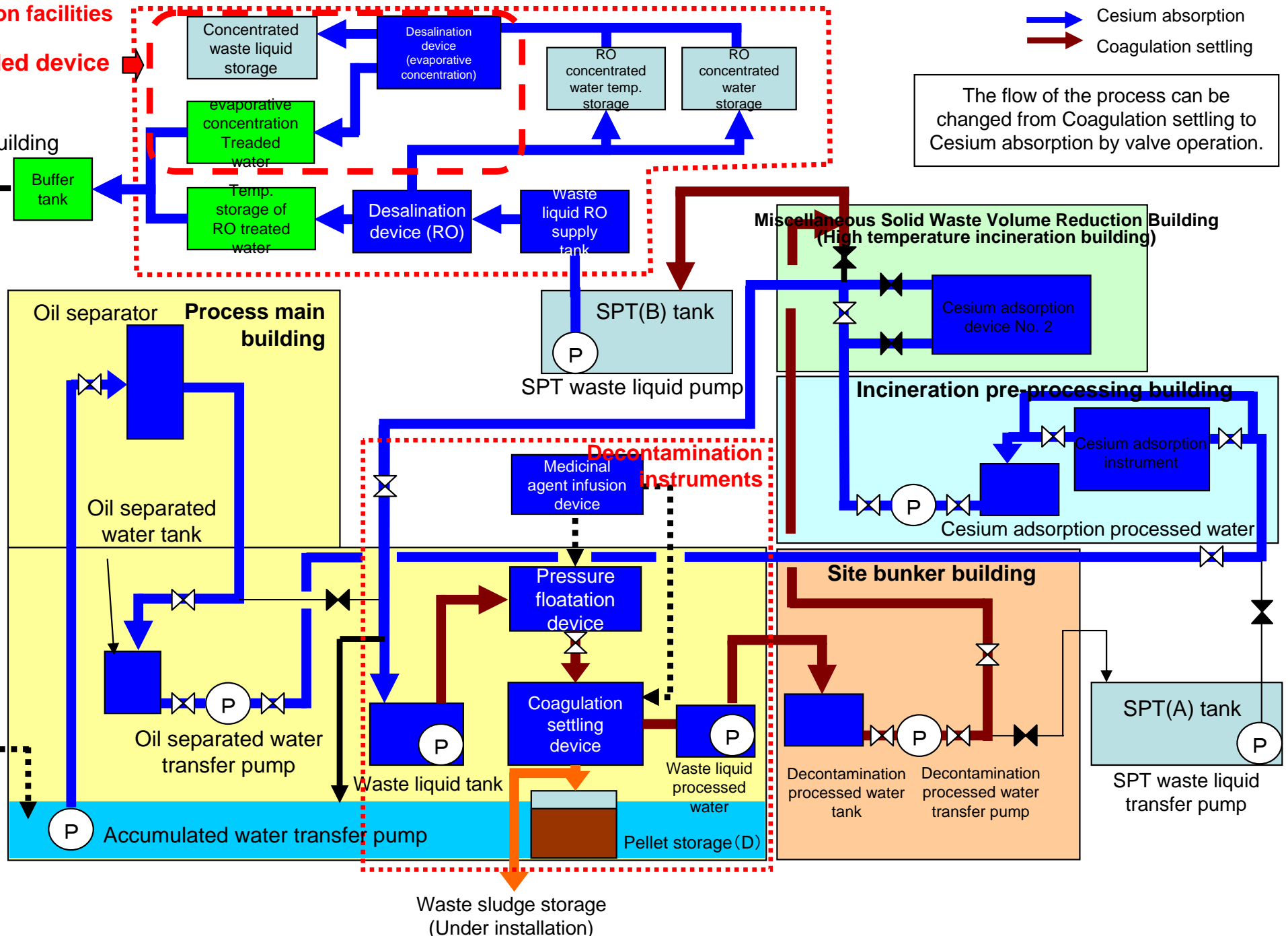
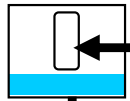

Process: Process main building → Oil separator → Cesium absorption instrument → Decontamination instrument → Desalination instruments