<Reference>

October 29, 2011

Tokyo Electric Power Company

**Recovery and processing of radioactive
accumulated water at Fukushima Daiichi
Nuclear Power Station**

- Water processing facility (removal of
radioactivity) -**

Overall structure of water processing

- Installed to account for the risk of environmental pollution by leakage and radiation exposure by the large quantity of highly radioactive accumulated water
 - Prevent leakage of accumulated water → transfer and store radioactive substances
 - Prevent dispersion of radioactive substances → absorb and immobilize or condense
 - Mitigate generation of accumulated water → re-circulate

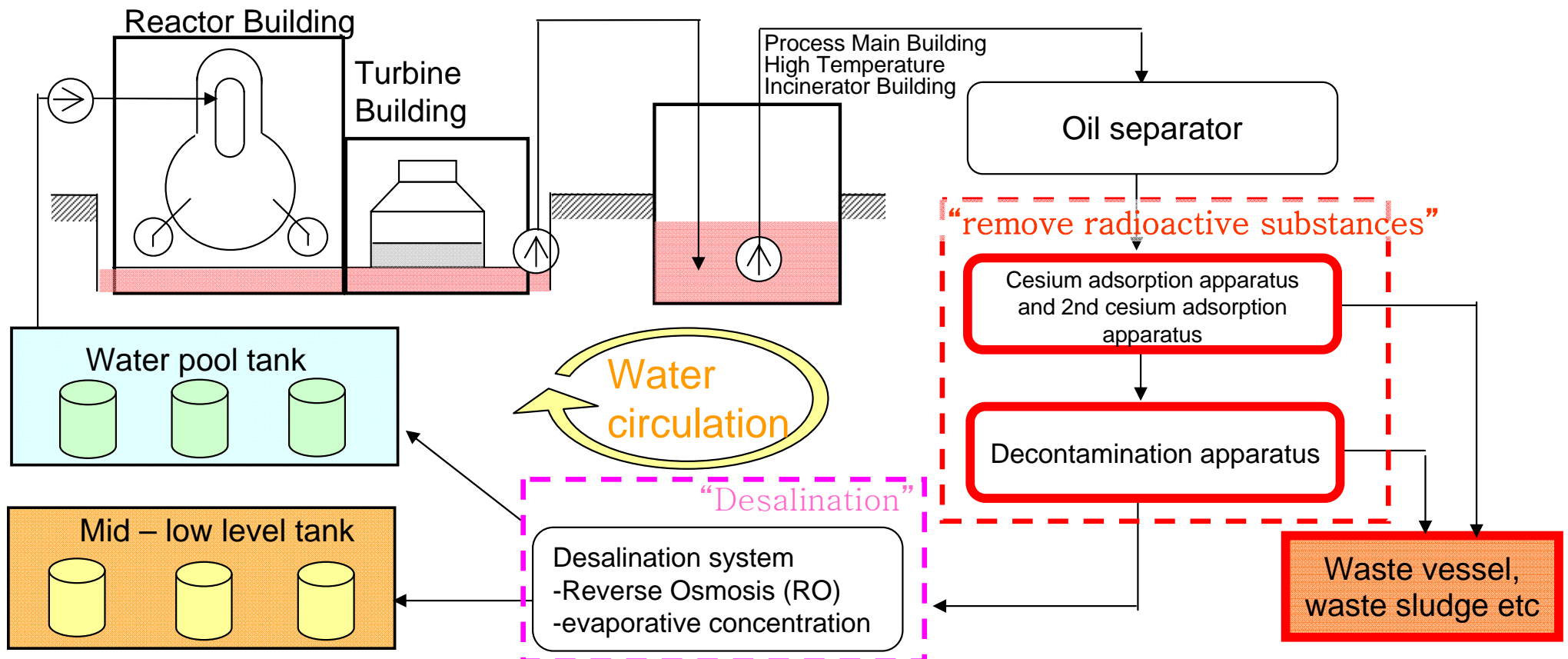

Cesium adsorption apparatus (Kurion)

- Cesium adsorption facility decontaminates by three kinds of adsorption towers.
- There are 4 series. By adjusting pumps to the apparatus, pumps of each series and valves, the processing volume can be adjusted between 15m³/h and 50m³/h. (can be operated with low processing volume, below 20m³/h with 1 series operation)

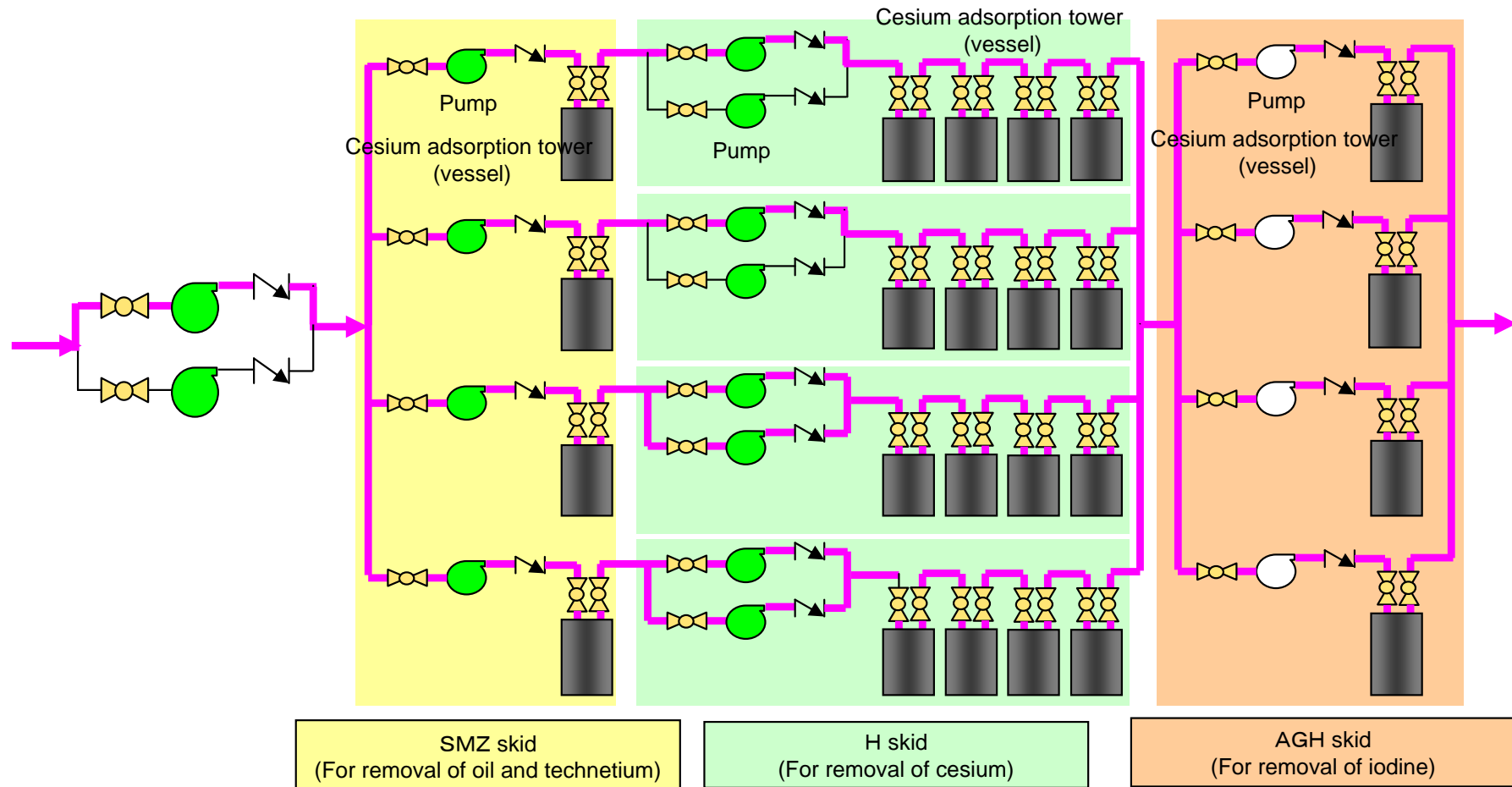

2nd Cesium adsorption apparatus (SARRY)

- 2nd Cesium adsorption apparatus decontaminates by two kinds of filters and adsorption tower.
- There are 2 series. By adjusting pumps of each series and valves, the processing volume can be adjusted between 25m³/h and 50m³/h.

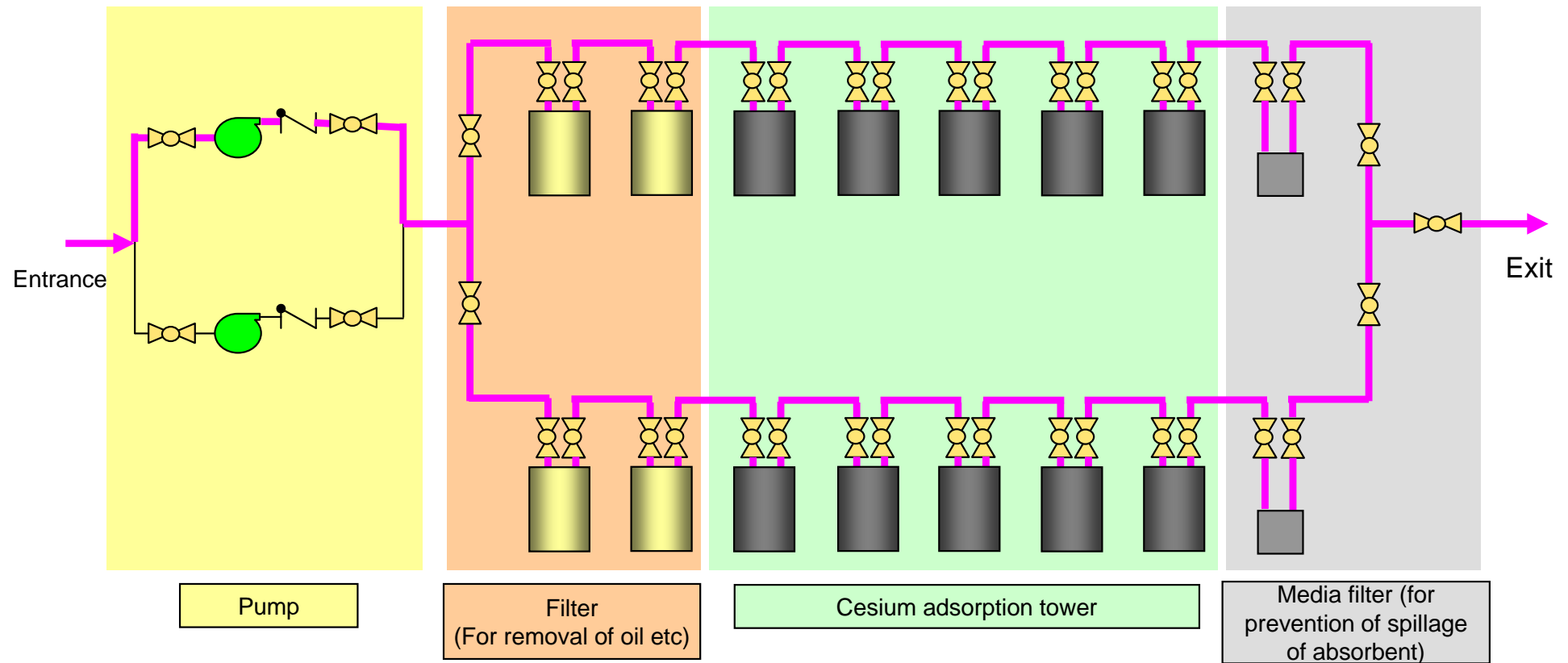

Immobilization and condensation of radioactive substances① (adsorption tower)

■ Removal by adsorption tower

- Remove radioactive substances and contaminants by coursing accumulated water through adsorption tower filled with absorbent
- As a basic design, zeolite is used as absorbent to remove oil, technetium (Tc), cesium (Cs) and iodine (I).
 - ◆ Purify water by using ion-exchange effect of zeolite and absorbing radioactive substances such as cesium.
 - ◆ Zeolite is a generic term for those with relatively large voids in the crystal structure of aluminosilicate. Inorganic materials and have excellent resistance to radiation.
 - ◆ Using zeolite proven at Three Mile power station in the U.S. and improved zeolite.



Example of zeolite



- The structure of zeolite is, (i) aluminum (valence +3) and silicon (+4 valence) share oxygen (valence -2) with each other, (ii) around the silicon is electrically neutral, (iii) around aluminum is valence -1, (iv) to neutralize this negative charge, cations can enter the framework.
- Different cations are likely to be captured by different composition and spatial structure. Use zeolite that selectively captures Cs⁺.

Cations in the framework is replaced with Cs.

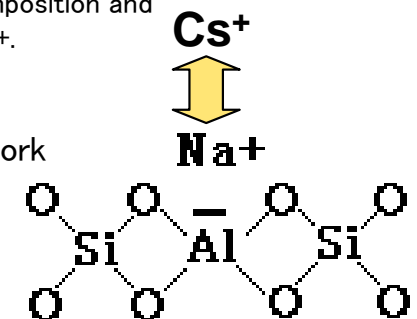

Radioactive waste (Waste vessel)

- Radioactive-removed adsorption towers (vessels) are utilized as containers for storage containers for radioactive waste including adsorbed radioactive materials.
 - Stored in waste vessels (iron containers) + concrete containers
 - In addition, radiation dosage is reduced by sandbags at the storage area.
- Removal of radioactive materials and salt is smoothly carried out by circulating injection cooling operation and the vessel replacement interval is extended. The occurrence rate of amount of waste materials is reduced.

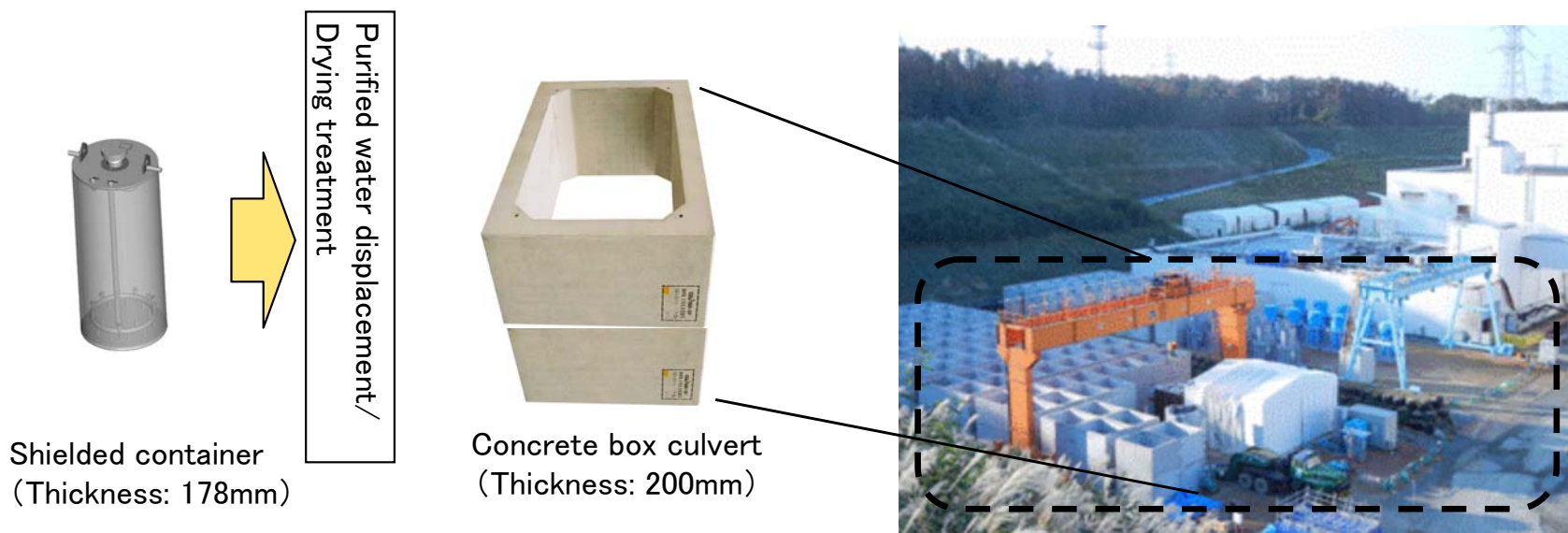

Decontamination instruments (Areva)

- Decontamination instruments are composed of pressure floatation device (removal of oil, etc.), coagulation settling facility (multi-flow, acti-flow) and disk filter (prevention of outflow of suspended solids, etc.), and can do bypass operation of the individual instrument, depending on conditions of decontamination and instruments.
- The instruments are automatically in a standby mode when the inflow disappears, and start the process when a certain amount of inflow comes.

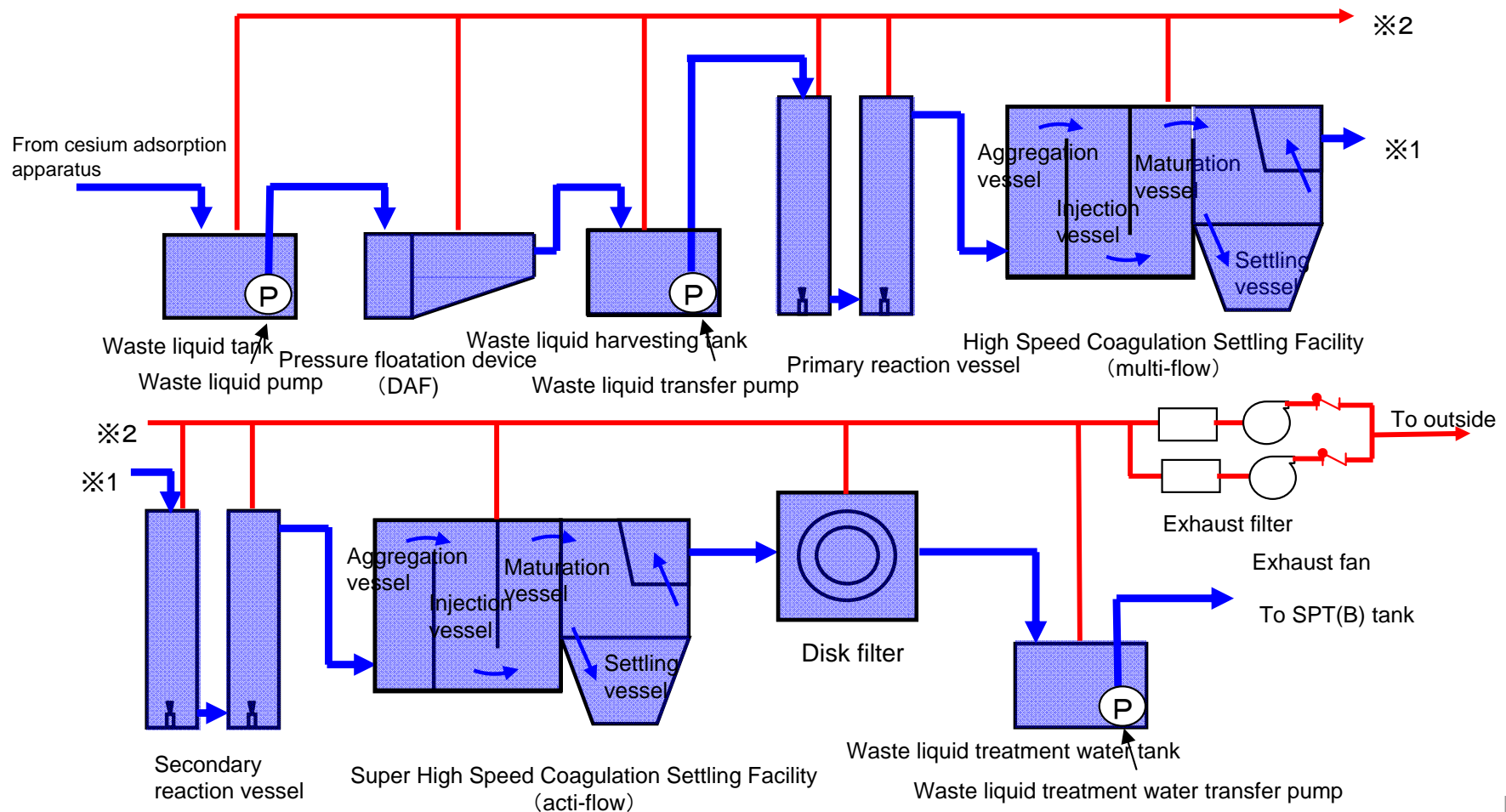

Immobilization and condensation of radioactive substances ② (coagulation settling)

■ Removal by coagulation settling

- Adsorb radioactive substances such as cesium (Cs) by adsorbent solution and settle out by flocculant. Separate into the sunken waste sludge and treated supernatant water and discharge only supernatant water.
 - ◆ The adsorbents are examined and selected from proven adsorbents in Areva
 - ◆ The optimal flocculants are selected and blended by water treatment technology and experience of Veolia and experiments.

Experimental example of coagulation settling

Differences of settling status with following flocculants indicated by the elapsed time differences against the same contaminated substance

- ①: Only inorganic flocculant
- ②: Inorganic and organic flocculants
- ③: ② and silicate flocculant

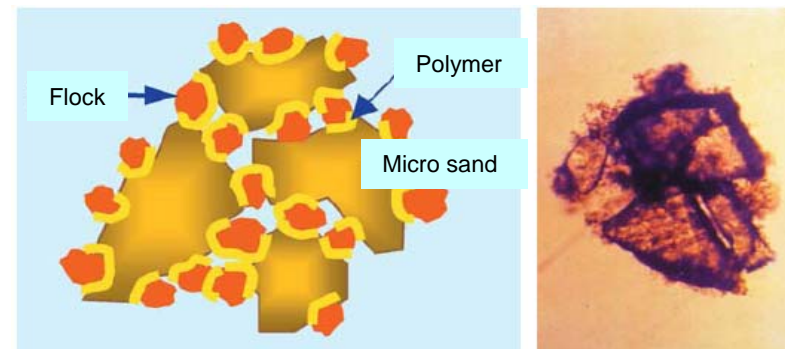
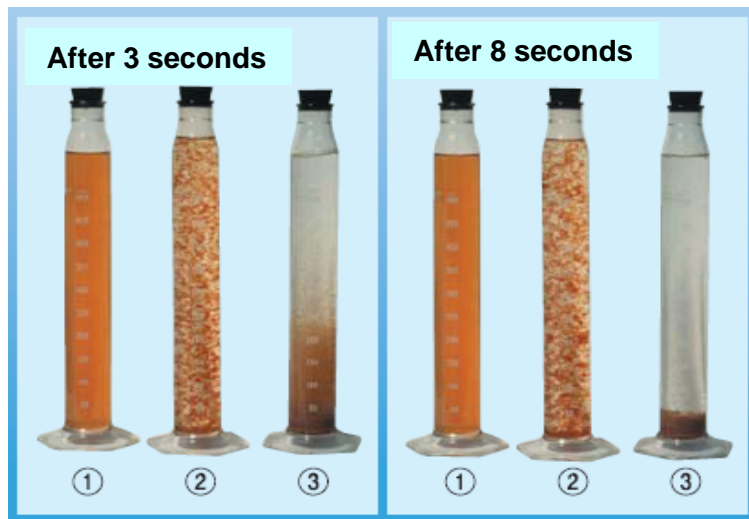

Example of contaminated substance (Flock)

Radioactive waste (Waste sludge)

- Waste sludge is temporarily stored in the radioactive waste (pellet) storage in the process main building.
 - Store in the pellet storage in the basement of the building (of 1m thick concrete).
(approx. 580m³ as of Oct 25)
 - It is assumed that there is no discharge of the waste sludge to outside of the building because the pellet storage has no direct contact surface to the ground and walls and floor of the building are located around the storage.
- The waste sludge will be transferred and stored in the iron tank (25mm thick) installed in the cell room (of 1m thick concrete) of sludge storage facility under construction in the future. [Storage capacity 630m³ No expansion plan]



Iron storage tank for sludge in progress
(External appearance)



Iron storage tank for sludge in progress
(Inside)

Transition of the water treatment facility (1/4) Till adoption decision of the apparatus

- March 11 Inflow of seawater
- March 24 3 workers from the cooperating companies who were engaged in the cable installation work on the first floor and in the first basement of the turbine building, Unit 3 were exposed to over 170 mSv of radiation. (Because they worked with their feet soaked in high-dose contaminated water)
- March 24~27 Conducted sampling of the accumulated water of Unit 1 to 4. Existence of high-dose radiation was verified from the result of analyses. Started consideration of the removal.
- In early April Suggestion from Areva
→ Decided adoption of decontamination instruments by the prospect for commencement of operation in a short period, decontamination capability based on the experience and the processable water quantity and so on.
- In mid-April Suggestion from Kurion
→ Planned to purchase only cesium adsorbent at first, but decided adoption of complete set of the cesium adsorption apparatus by introduction from EPRI and domestic company.
- In early May Suggestion from TOSHIBA
→ Decided introduction of 2nd cesium adsorption apparatus to treat a large volume of contaminated water promptly and to increase the processable capacity of the water treatment facility.



Kurion
Cesium adsorption apparatus
June 8, 2011
Photo by TEPCO

Areva
Decontamination instruments
(pressure floatation device)
June 1, 2011
Photo by TEPCO



Transition of the water treatment facility (2/4) Track record of water treatment facility installation

- April 30 Decided installation of the water treatment facility composed of oil separation apparatus, cesium adsorption apparatus, decontamination instruments and water desalinations (RO) and started construction
- June 14 Start of test operation
- June 17 Start of operation



**H skid
(Cesium adsorption tower)**
June 6, 2011
Photo by TEPCO



**Super high speed coagulation settling decontamination facility
(Decontamination instrument)**
June 15, 2011
Photo by TEPCO



**Disk filter
(Decontamination instruments)**
June 5, 2011
Photo by TEPCO



**Reaction vessel
(Decontamination instrument)**
June 7, 2011
Photo by TEPCO

Transition of the water treatment facility(3/4) -The 2nd cesium adsorption apparatus construction

- July 26: Start of installation of adsorption towers of the 2nd cesium adsorption apparatus
- August 16: Start of test operation
- August 18: Start of operation



Vessel Transfer
June 1, 2011
Photo by TEPCO



Crane for vessel replacement
August 2, 2011
Photo by partner company



Cesium adsorption towers and media filter
August 2, 2011
Photo by partner company

Transition of the water treatment facility(4/4) - Facility improvement and example -

- June 10: Leakage from the pipe connections at the Cesium adsorption apparatus were found.
 - Caulked by sealant with radiation hardness.
- June 17: Whole water treatment system was suspended due to the signal of the intermittent operation in the decontamination instruments.
 - Change the logic at the intermittent operation.
- June 22: Dose of radiation were increased near the exit of AGH skid at the Cesium adsorption apparatus
 - All valves were inspected. An error of the open and closed indicator was found and modified.
- July 10, 12, and 13: Chemical leakage due to the damage of chemical injecting line connection at the decontamination instruments.
 - Replace the connection material from vinyl chloride to stainless.
- August 4 and 7: Suspension of the chemical injection pump of the decontamination instruments and automatic start failure of backup equipment.
 - Change the rotations of the pump and the logic of signal of back-up equipment.
- September 8: Pressing an emergency stop button in mistake for an alarm of a control panel nearby it at the 2nd Cesium adsorption apparatus
 - Retraining the operation procedure and precautions. Sharing the cases.



Although several failures and troubles occurred at the beginning of the operation, we achieved stable operation by taking measures to prevent a recurrence of the troubles.

Decontamination of Radioactive substances

Situation of Radioactive substances

- At the development stage (From the result of analysis of Turbine building and Vertical shaft)
 - ◆ Highly concentrated radioactive--dose level more than 1,000mSv/h
 - Main nuclide----Although the concentration differs from reactors, we assume the ^{131}I 、 ^{134}Cs 、 ^{137}Cs are main nuclide based on its concentration.
- Decontamination
 - ◆ We plan the removal of main nuclide

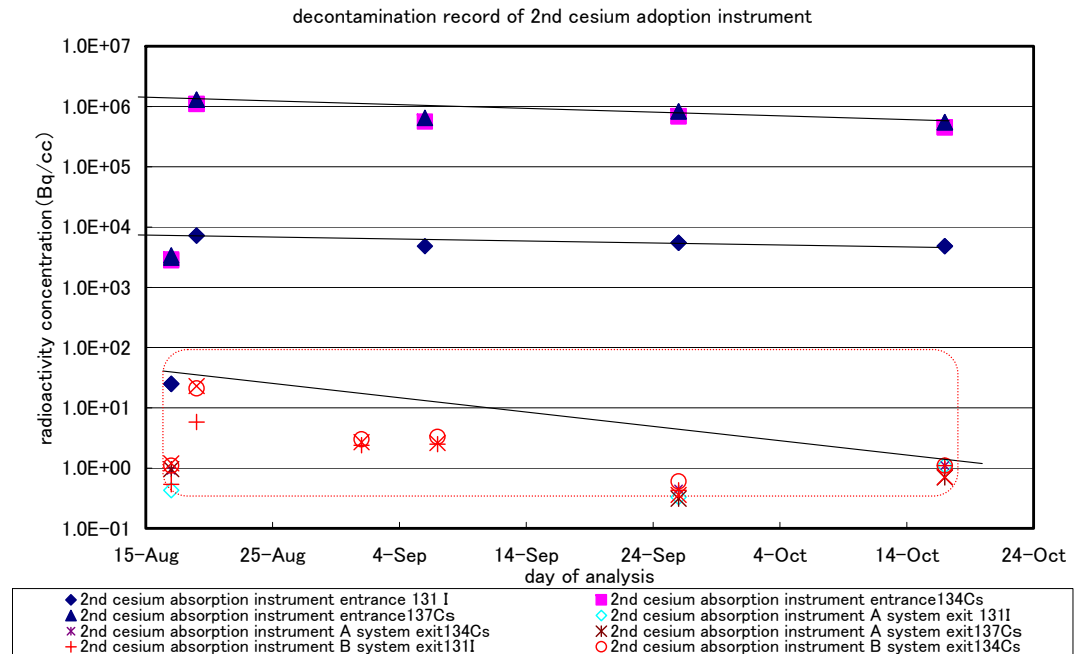
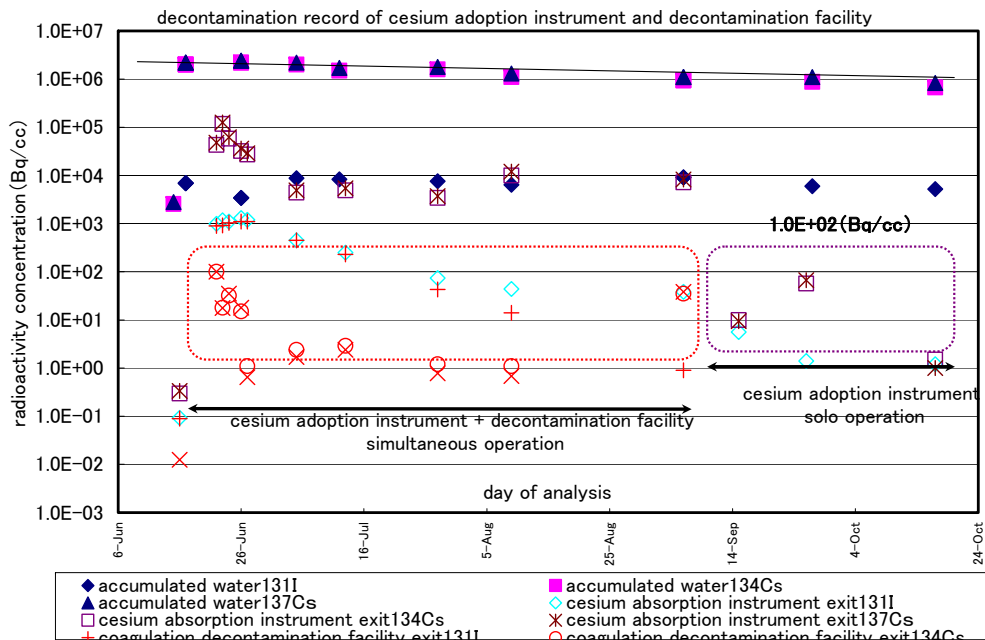

-Cesium level of the accumulated water is declining.
-The level of concentration both consolidated and individual operations are lower than $1.0\text{E}+02\text{Bq}/\text{cm}^3$. It can meet the criteria to transfer to the Desalination system.
-The concentration level of 2nd Cesium adsorption apparatus is declining after the decontamination.

Processing volume and storage volume

- Processing volume ····· Maximum record is up to $\sim 71 \text{ m}^3/\text{h}$ ($1,692 \text{ m}^3/\text{d}$)
 - Keep the water level in the building by securing the amount of cooling water and processing influent water
- Storage Volume ····· $77,000 \text{ m}^3$ with a total btw. No.1 and No.4, $17,000 \text{ m}^3$ with a total of Process Main Building and High Temperature Incinerator (HTI) Building (as at October 25)
 - Storage at the building of Reactor, Turbine, Process Main and HTI.
 - The storage volume decreased approx. $94,000 \text{ m}^3$ which was approx. $120,000 \text{ m}^3$ in late June.
- The water level of the turbine building of Unit 2, 4 were kept at around OP3m.

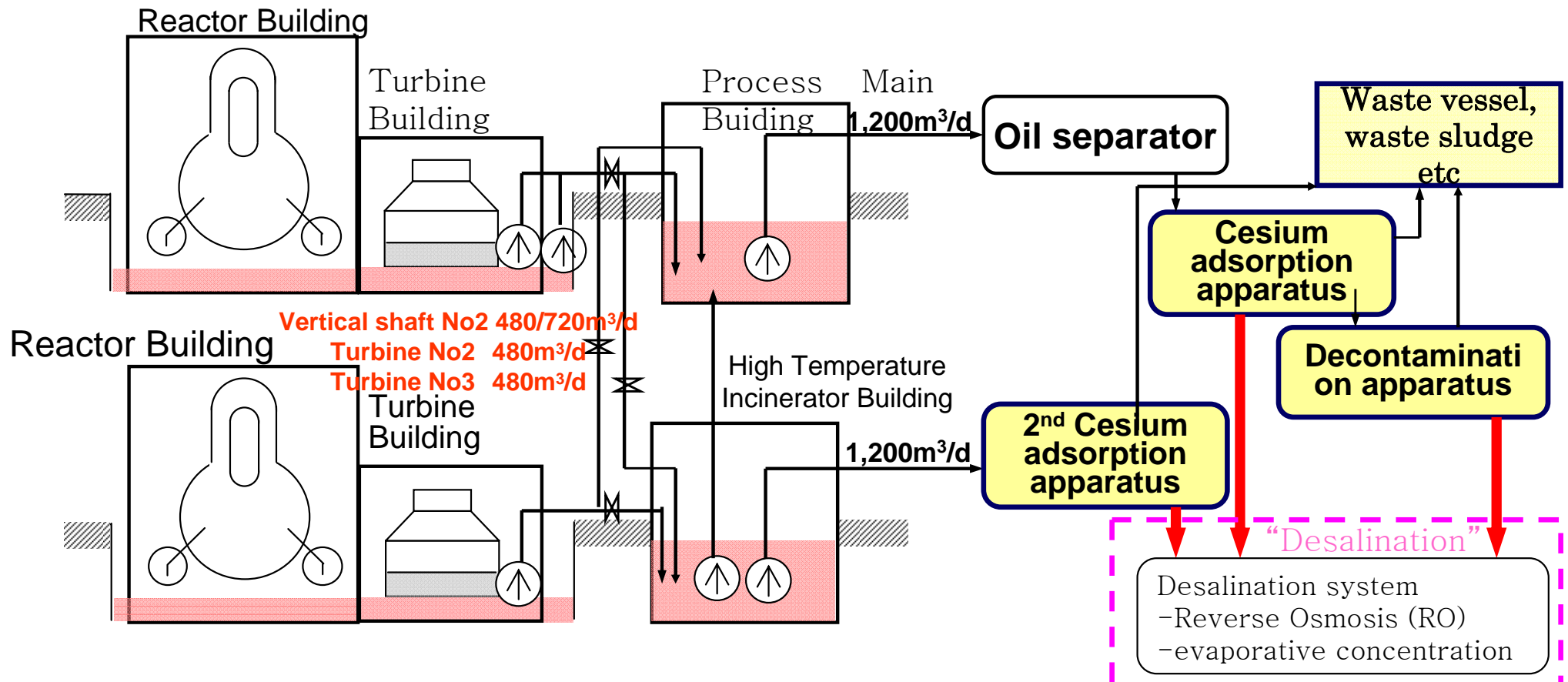

Water processing record

- Processed and desalinated approx 140,000m³ (October 25)
 - June 14 Commenced test-run of Cesium adsorption apparatus and decontamination apparatus
 - June 17 Put above apparatuses in operation
 - August 16 Commenced test-run of 2nd cesium adsorption apparatus
 - August 18 Put the above apparatus in operation

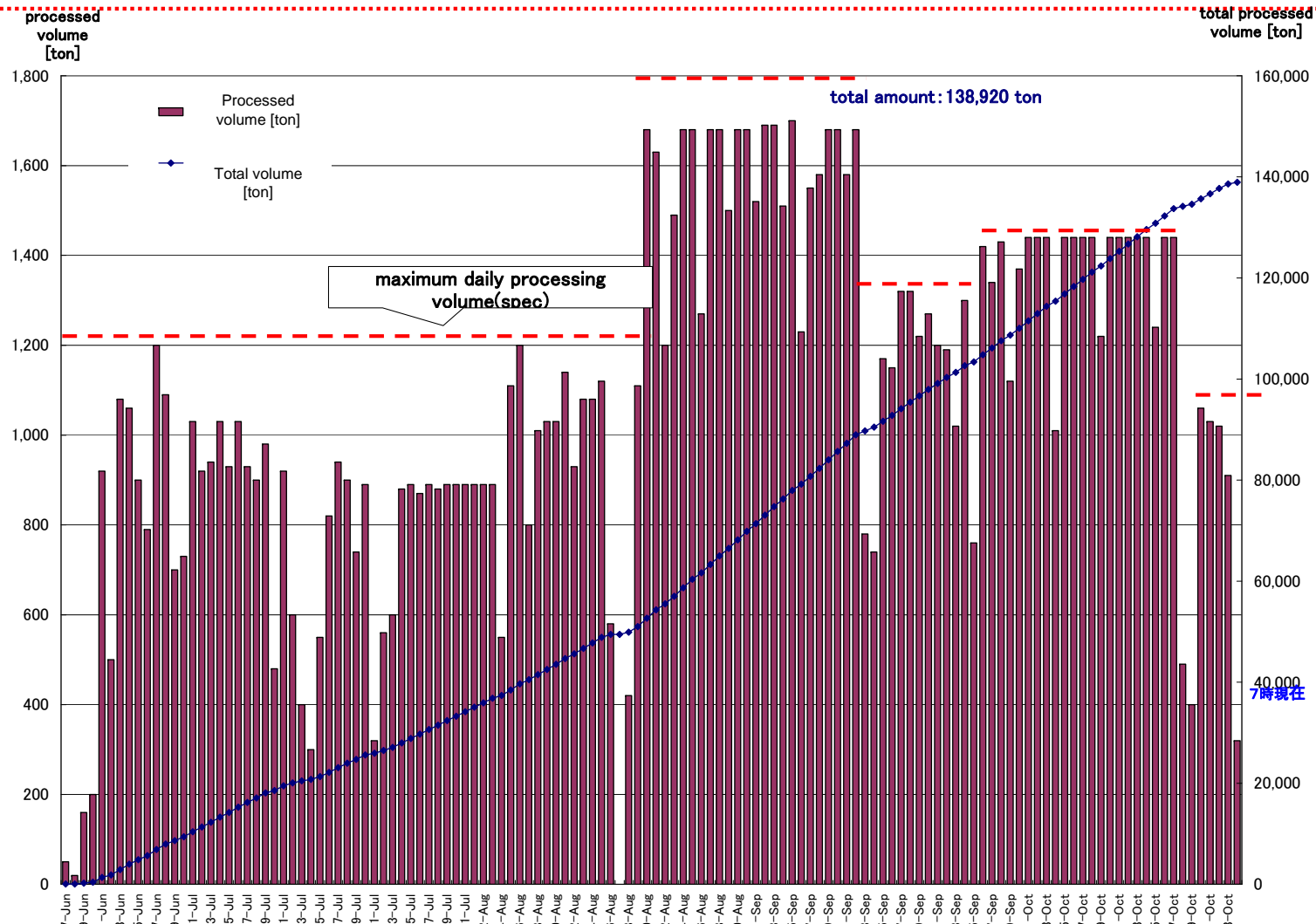

The status of water processing and future policy

Water level in buildings and processing volume

- Water level in Turbine Building is on a declining trend and maintaining around OP3m.
- Water levels in Process Main Building and High Temperature Incinerator Building are stable.
- Processing around 50m³/h.

In order to suppress generation of radioactive waste, our policy for the moment is to mainly use 2nd cesium adsorption facility and use Cesium adsorption facility as backup on a standalone basis. Coagulator is further backup.

Water level trend in Turbine Building of Units 2 and 3, Process Main Building and Miscellaneous Solid Waste Volume Reduction Treatment Building

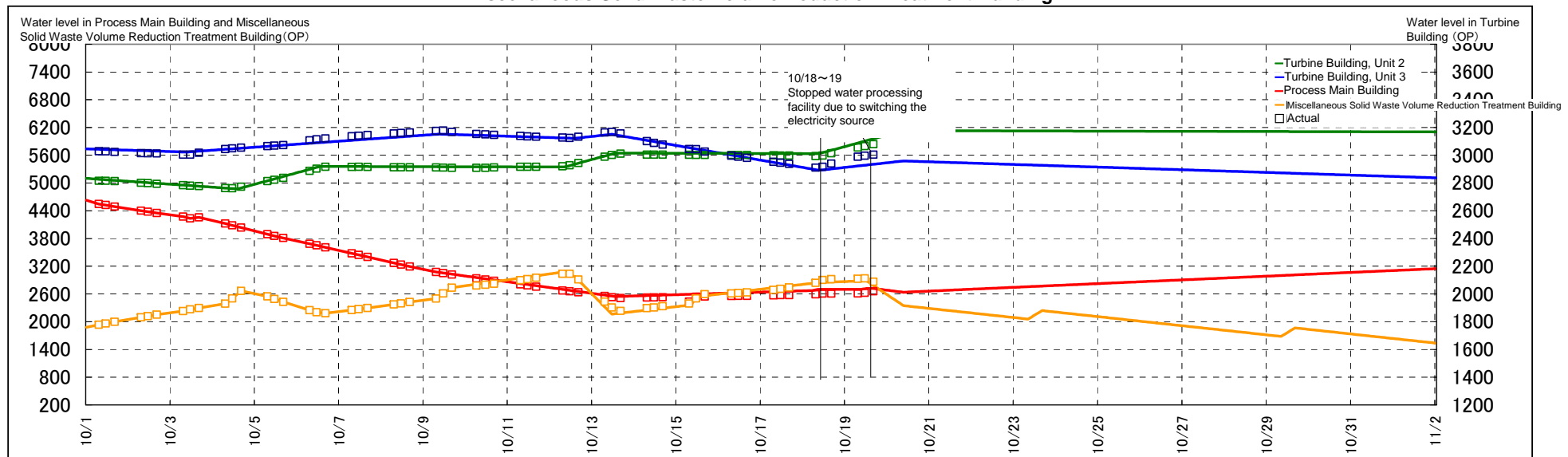

Future facility measures for water processing

- Corrosion protection
 - Installation of sacrificial electrodes, the implementation of anti-corrosive paint, evaluation of corrosion and installation.
 - Although demineralization is progressing, evaluate the design to confirm whether the facility withstands future use and conduct repair work.
- Measures for hydrogen gas
 - Hydrogen gas is generated by water radiolysis.
⇒ Installation of exhaust ventilation, scavenging facility (e.g. compressors), drying and replacement
- Measures for radioactive substances
 - In order to remove radioactive substances further, we are studying and selecting new processing equipments.



**Exhaust ventilation apparatus,
decontamination facility**



**Compressor,
decontamination facility**