

Unit 4 Spent Fuel Pool Alternative Cooling System Suspended at Fukushima Daiichi Nuclear Power Station (Occurred on June 30, 2012)

< Reference >

July 2, 2012

Tokyo Electric Power Company

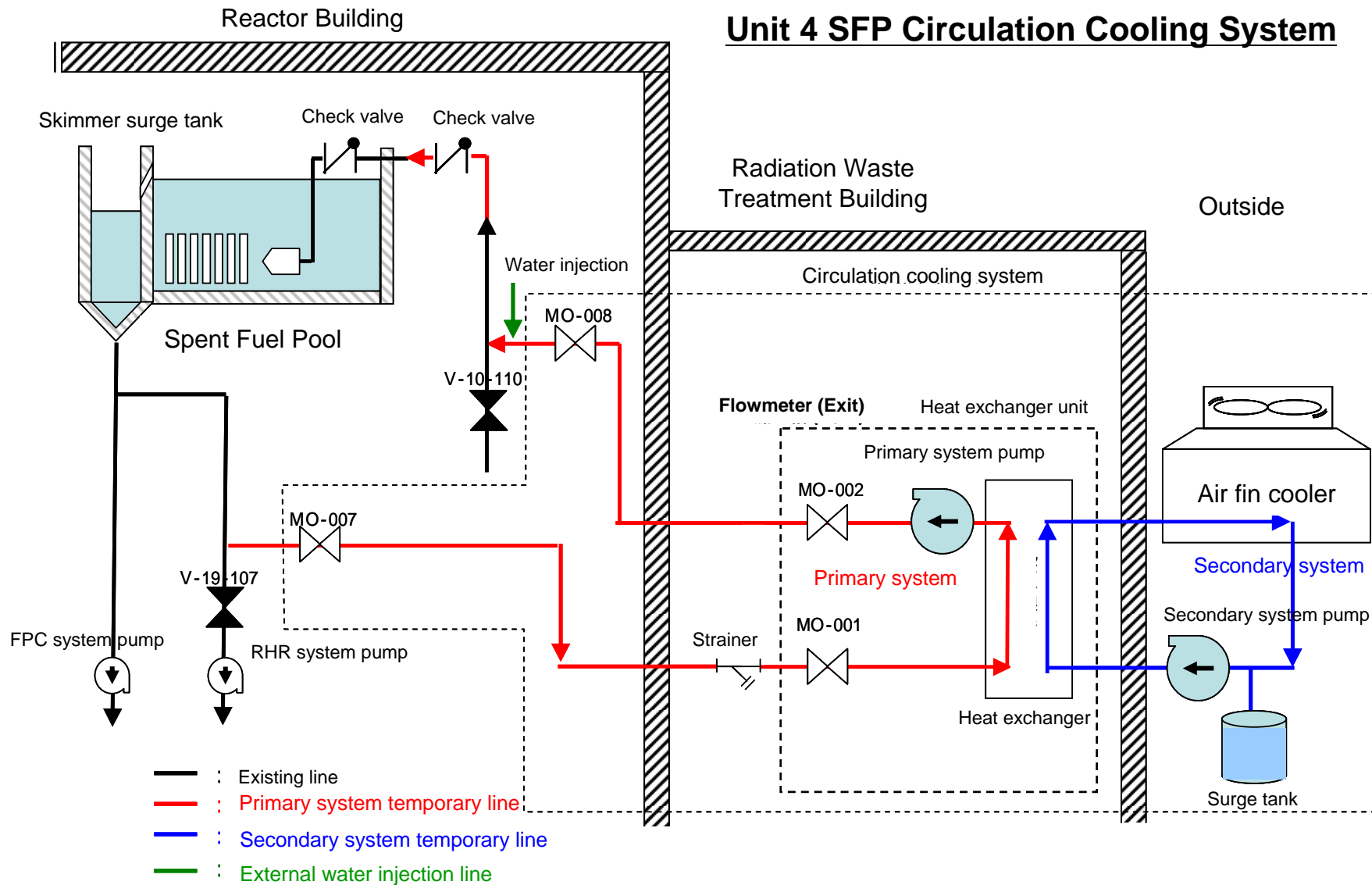

Power Supply to UPS (Uninterruptible Power System)

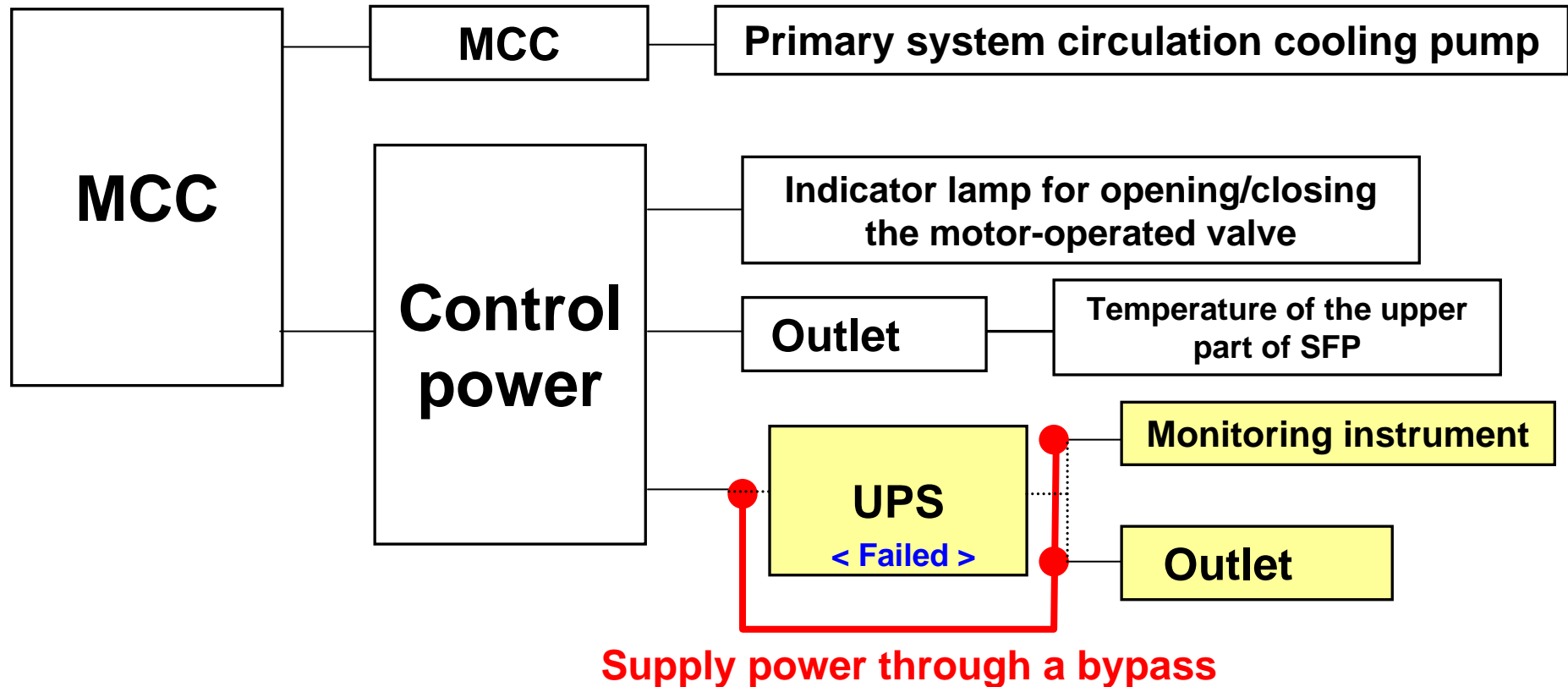

Upon investigation, it was confirmed that a system trip occurred as a result of UPS failure causing the loss of power supply to the monitoring instrument. The cooling system was recovered by supplying power to the monitoring instrument through a bypass. After replacing the failed UPS, power supply through UPS will be recovered.