

< Reference >  
July 5, 2012

Tokyo Electric Power Company

# **“Development of Remote Decontamination Technology” Result of Unit 2-3 Reactor Building Investigation**



**東京電力**

---

TEPCO

# Site Investigation Items and Schedule

## 1. Purpose

Investigate the decontamination condition of the Reactor Building and acquire data useful for the “development of remote decontamination technology”.

## 2. Investigation Items

The items below will be investigated in Unit 1-3 Reactor Building.

-Radiation source and dose rate investigation by a robot → Radiation doses of Unit 2 and 3 are provided in the report (Unit 1 radiation dose was reported on May 25.)  
Gamma camera and dosimeter to be used.

-Decontamination condition investigation by workers

Samples of dust, peeling paint and drilling core will be analyzed at JAEA Oarai Research and Development Center. (Unit 1 sample has been sent on June 22, Unit 2-3 samples will be sent on July 18.)

## 3. Site Investigation Schedule

Item	Unit	May					Jun.						Jul.			Aug.								
		14	18	21	28	31	1	7	11	13	14	15	21	25	28	29	30	Early	Mid	End	Early	Mid	End	
Gamma camera/ Dose rate	1	■																						
	2				■																			
	3							■																
Decontamination condition	1							■																
	2							■																
	3													■										
Decontamination sample analysis	1																	■						
	2																							
	3																							

Analysis completion of Unit 2-3 samples is not yet determined

# Dose Rate Measurement Result: Unit 2 Reactor Building 1st Floor

Dose rate measurement result

[Unit: mSv/h]

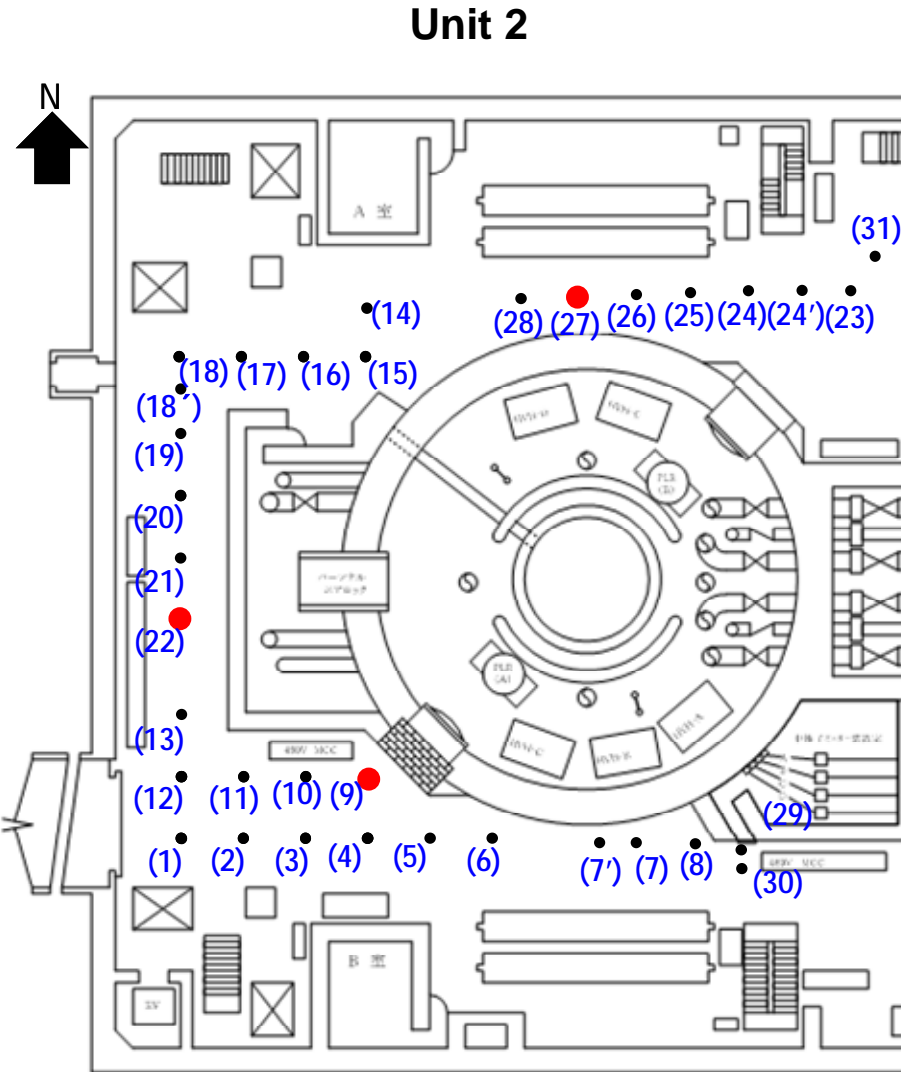

Point	5cm above the floor	150cm above the floor	Point	5cm above the floor	150cm above the floor
[1]	6.9	12.7	[18]	8.9	8.9
[2]	13.4	18.2	[18]	5.5	6.8
[3]	19.5	18.4	[19]	6.8	8.5
[4]	14.1	17.9	[20]	7.2	12.4
[5]	10.5	18.5	[21]	6.6	10.8
[6]	14.6	30.3	[22]	7.7	10.8
[7]	15.5	-	[22] Wall	8.4	8.4
[8]	10.8	-	[23]	9.8	11.6
[9]	14.7	21.6	[24]	13.7	14.4
[9] Wall	14.5	10.8	[24]	12.6	16.8
[10]	14.3	15.9	[25]	16.0	15.7
[11]	10.9	17.3	[26]	18.2	15.2
[12]	10.3	15.7	[27]	40.8	14.3
[13]	11.0	16.5	[27] Wall	15.4	12.0
[14]	7.2	10.8	[28]	23.8	15.4
[14]	13.7	12.3	[29]	10.5	-
[15]	9.2	8.7	[30]	10.3	-
[16]	7.8	8.7	[31]	8.9	11.0
[17]	7.4	9.8	-	-	-

# Dose Rate Measurement Result: Unit 3 Reactor Building 1st Floor

Dose rate measurement result \*50mSv/h or more: indicated in red [Unit: mSv/h]

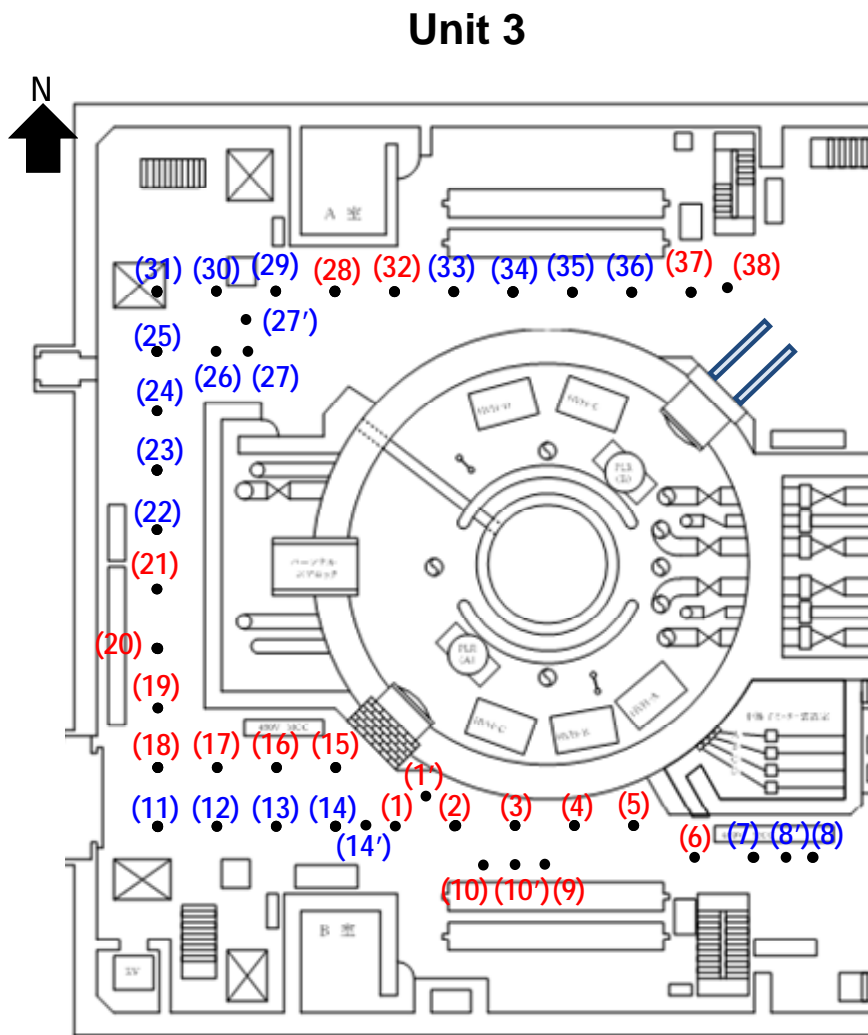

Point	5cm above the floor	150cm above the floor	Point	5cm above the floor	150cm above the floor
[1]	82.1	44.7	[19]	94.0	98.7
[1']	74.3	51.6	[20]	73.2	65.3
[2]	97.4	78.0	[21]	68.8	49.2
[3]	89.1	73.5	[21] Wall	65.4	42.4
[3] Wall	72.3	77.9	[22]	40.0	35.1
[4]	81.7	91.4	[23]	35.2	24.1
[5]	65.5	64.9	[24]	21.7	21.4
[6]	60.0	25.7	[25]	33.5	24.5
[7]	15.9	16.2	[26]	21.7	24.9
[8]	15.7	15.8	[27]	21.7	27.5
[8']	18.5	17.8	[27']	17.7	24.4
[9]	87.8	85.2	[28]	73.0	35.5
[10]	91.5	74.5	[29]	24.1	25.7
[10']	92.5	95.8	[30]	18.2	27.8
[11]	66.8	69.9	[31]	31.7	34.1
[12]	29.2	53.8	[32]	63.8	36.7
[13]	46.2	57.6	[33]	36.7	40.1
[14]	30.3	44.1	[34]	29.4	37.5
[14']	27.7	41.3	[34] Wall	27.1	37.4
[15]	69.8	41.3	[35]	27.7	41.7
[15] Wall	53.7	40.4	[36]	47.7	72.5
[16]	50.6	40.6	[37]	203.1	124.7
[17]	180.9	57.4	[38]	59.7	85.2
[18]	102.0	79.8	-	-	-

# Gamma Camera Images (Example): Unit 2 Reactor Building 1st Floor

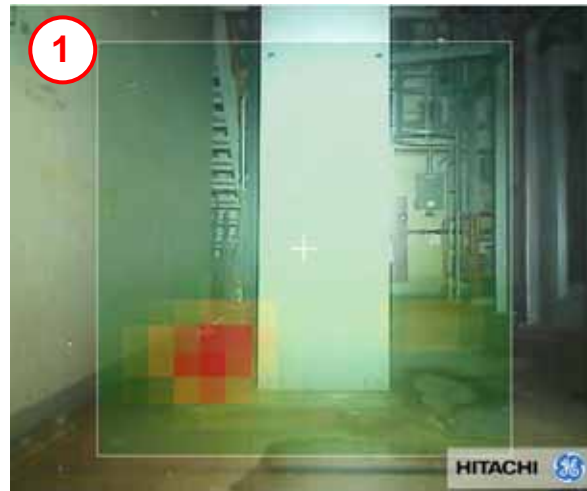
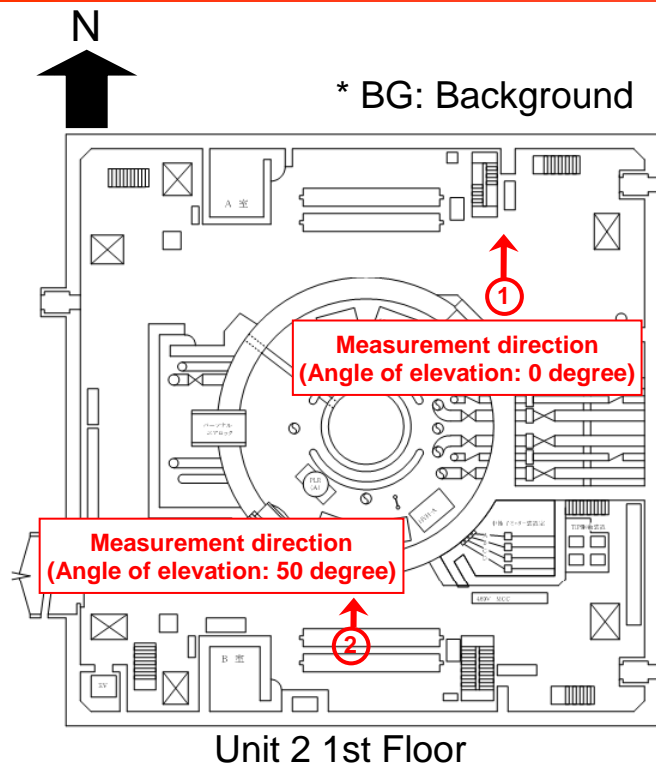

Image acquired at north side aisle before BG correction  
(Angle of elevation: 0 degree)



Image acquired at north side aisle after BG correction  
(Angle of elevation: 0 degree)



Image acquired at south side aisle before BG correction  
(Angle of elevation: 50 degree)

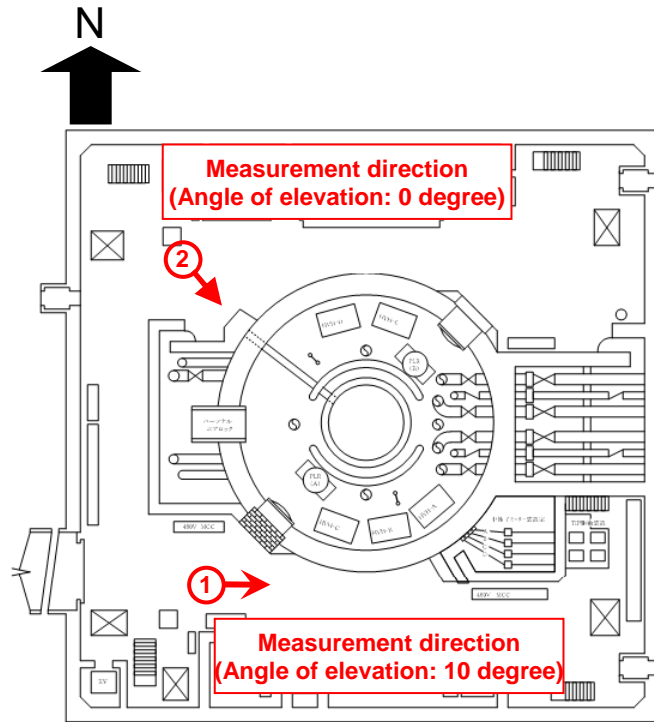

Image acquired at south side aisle after BG correction  
(Angle of elevation: 50 degree)

## Dose rate calculation

1. Calculate the ray count from the radiation source after BG correction.
2. Implement distance correction to calculate the ray count at 50cm from the radiation source surface.
3. Multiply the ray count after correction by the dose rate conversion factor to calculate the dose rate.

# Gamma Camera Images (Example): Unit 3 Reactor Building 1st Floor



Unit 3 1st Floor

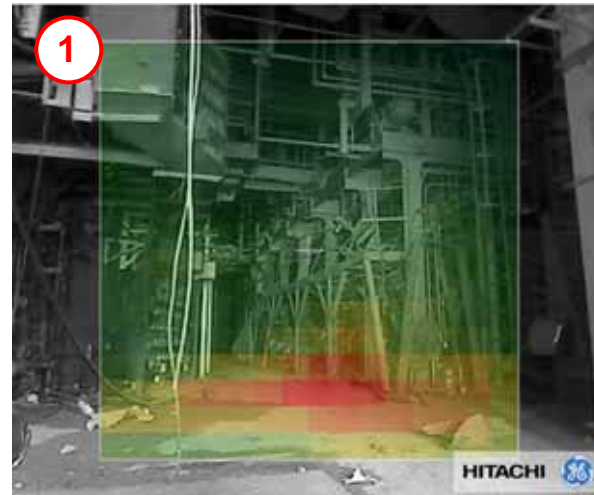

Image acquired at the large carry-in entrance  
before BG correction  
(Angle of elevation: 10 degrees)



Image acquired at the large carry-in entrance  
after BG correction  
(Angle of elevation: 10 degrees)



Image acquired at the northwest corner  
before BG correction  
(Angle of elevation: 0 degrees)



Image acquired at the northwest corner  
after BG correction  
(Angle of elevation: 0 degrees)

## Unit 2-3 Gamma Camera/Dose Rate Measurement

---

### Dose rate distribution

[Unit 2]

- No significant difference in the dose rate distribution among different areas (Range: 10-20mSv/h).
  - As is the case with Unit 1, the dose was higher at 150cm from the floor compared to 5cm from the floor.
- Assumed cause: the nuclides included in the steam that leaked from PCV are attached on the floor, walls and ceiling as there was no hydrogen explosion at Unit 2.

[Unit 3]

- There was a significant difference in the dose rate distribution among different areas (Range: 20-100mSv/h).
  - In about 50% of the entire area, the dose was higher at 5cm from the floor compared to 150cm from the floor.
- Assumed cause: Radiation sources are scattered on the floor as the debris and dust generated by the hydrogen explosion have not yet been removed.

### Radiation hot spot

- At Unit 3, the areas where debris and dust are accumulated are radiation hot spots.
- There are no radiation hot spots on the walls of Unit 2 and 3.

# Contamination Sample Analysis

---

## Purpose of Analysis

1. Confirm the validity of the sample (stable cesium: Cs133) used for decontamination testing in terms of the amount attached on the surface and the permeability .
2. Understand the contamination conditions (elemental composition, etc.) of each unit in order to select the optimum decontamination method.

## Analysis Items (JAEA Oarai Research and Development Center)

- nuclides analysis and all / measurements of the contamination sample (dust, paint and concrete core)
- Confirm the level of contaminant permeability into the concrete core as well as the range of contaminant spreading in the planar direction by utilizing an imaging plate (sensitive film).
- Observe the sample surface with an electron microscope and analyze the chemical composition utilizing an elemental analyzer in order to confirm Cesium and its distribution on the border between the paint and concrete and in cracks.



# [Reference] Existing Data on Unit 2 Reactor Building 1st Floor

Unit 2 R/B 1st Floor

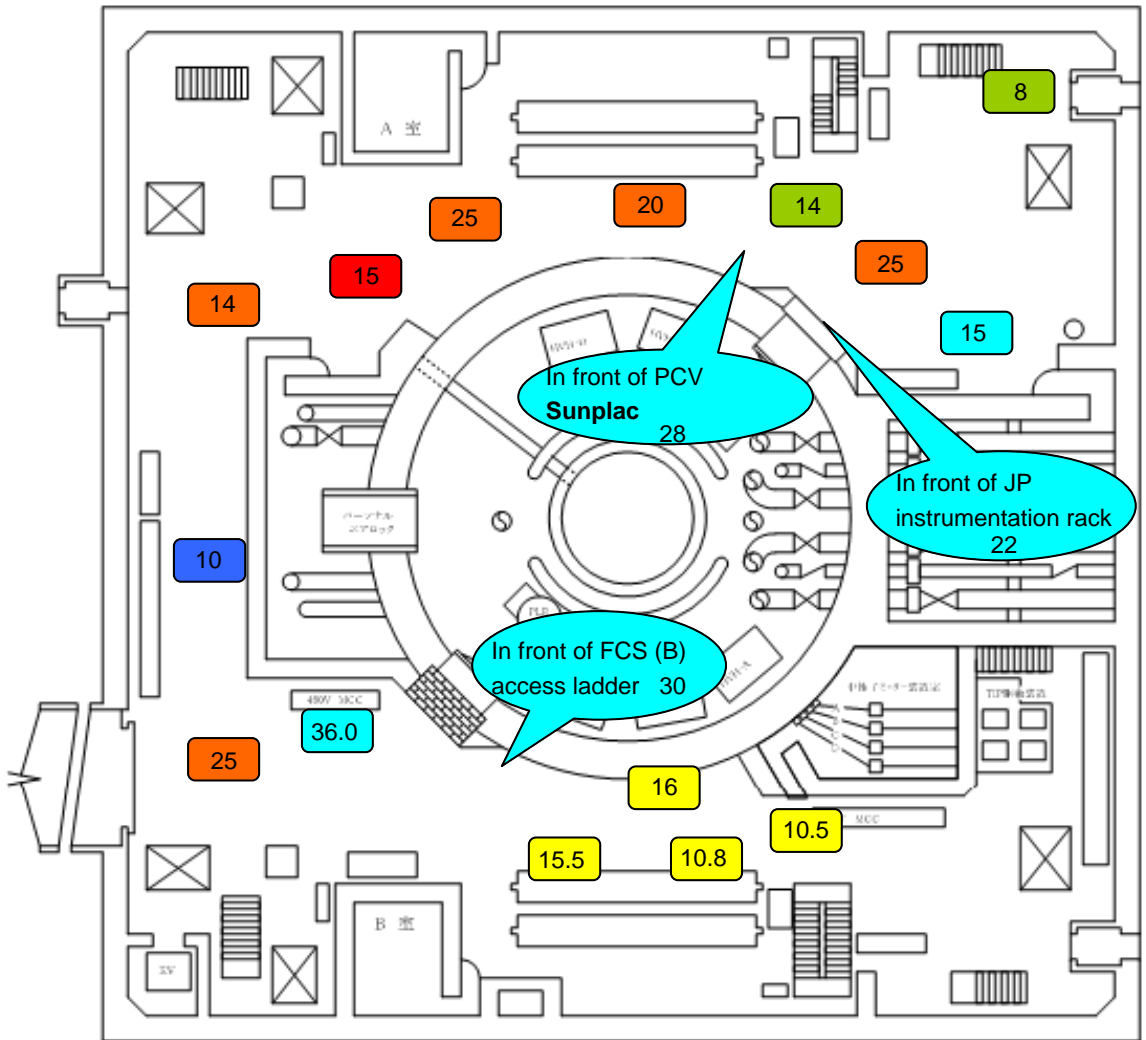

June 2011

October 2011

November 2011

December 2011

May 2012

June 2012

# [Reference] Existing Data on Unit 3 Reactor Building 1st Floor

Unit 3 R/B 1st Floor

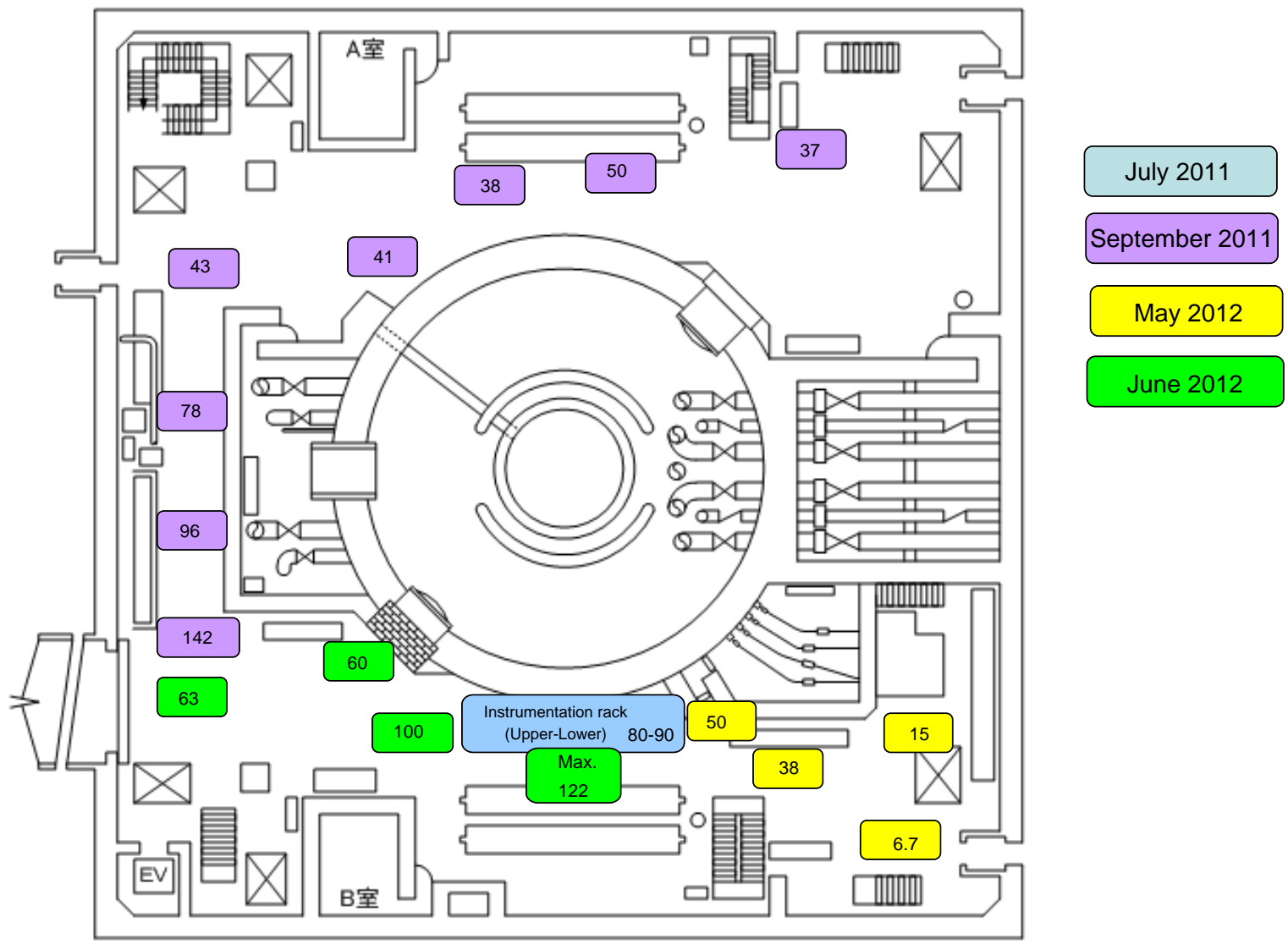

# [Reference] Dose Rate Measurement Result: Unit 1 Reactor Building 1st Floor

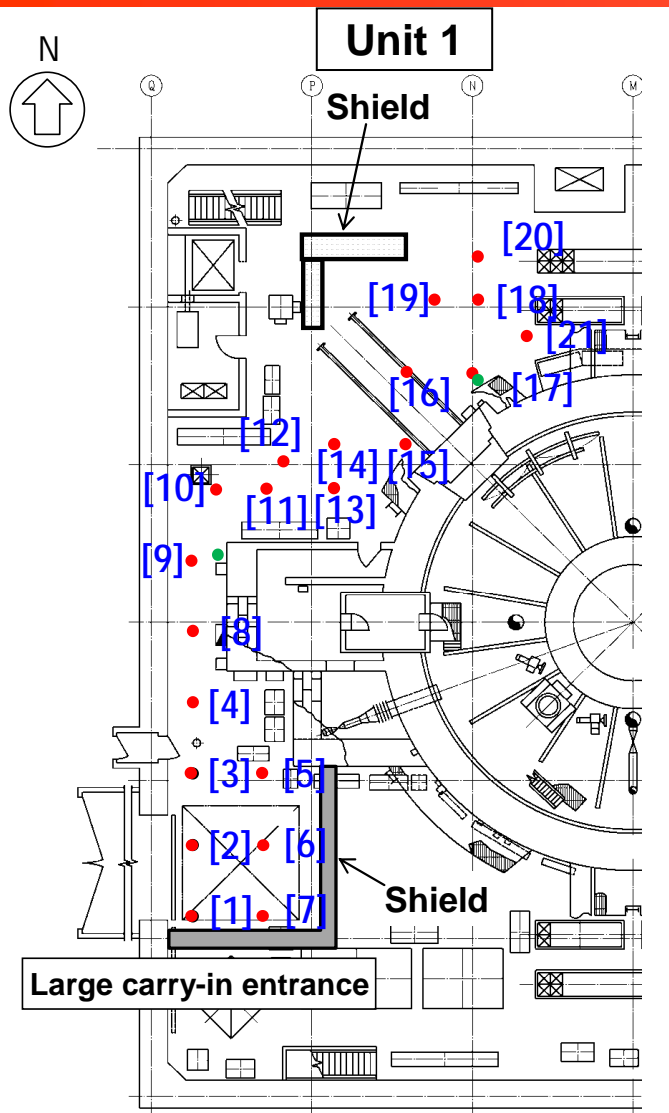

- Dose rate measurement point
- Dose rate measurement point (Wall)

**dose rate measurement result**

[Unit: mSv/h]

Point	Dose rate (50mm from the floor)	Dose rate (1,500mm from the floor)	Point	Dose rate (50mm from the floor)	Dose rate (1,500mm from the floor)
[1]	5.9	7.9	[12]	4.5	5.1
[2]	6.0	8.1	[13]	4.4	4.6
[3]	5.2	8.1	[14]	4.3	4.4
[4]	4.5	6.2	[15]	4.4	4.4
[5]	13.1	8.4	[16]	4.5	4.5
[6]	6.5	8.9	[17]	5.2	4.1
[7]	5.9	6.2	[17] Wall	5.1	4.0
[8]	4.3	5.1	[18]	5.1	4.9
[9]	2.5	3.8	[19]	3.3	4.0
[9] Wall	2.6	3.2	[20]	7.1	4.8
[10]	3.2	4.4	[21]	4.0	4.4
[11]	3.7	4.0			

**The dose rates at 1,500mm from the floor are slightly higher compared to 50mm from the floor.**

# [Reference] Gamma Camera Images (Example): Unit 1 Reactor Building 1st Floor

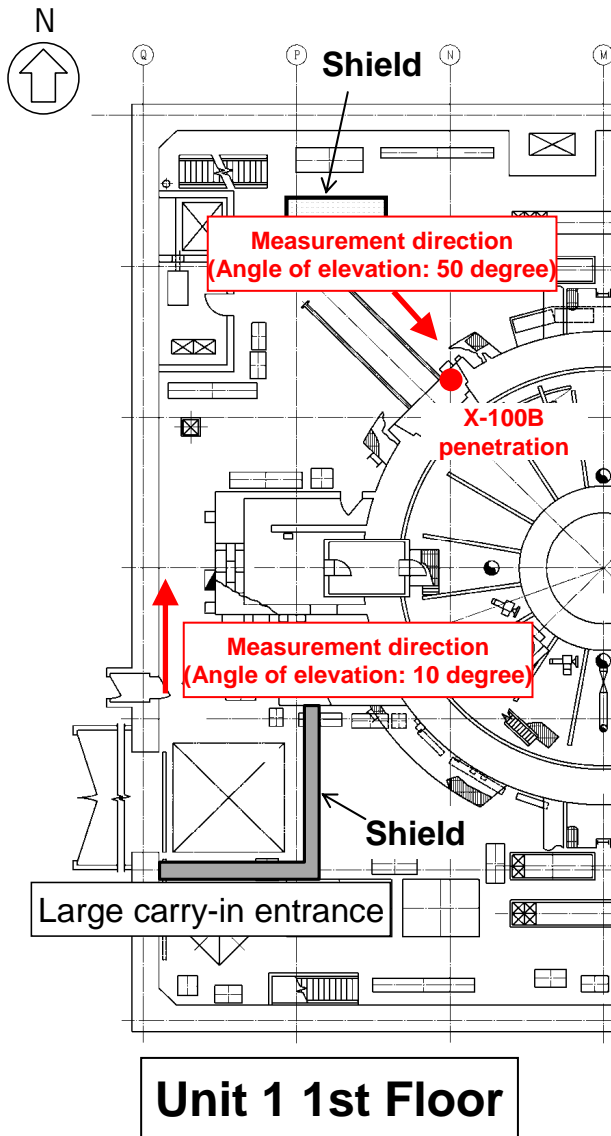

West side aisle (Unprocessed)



West side aisle (Processed)

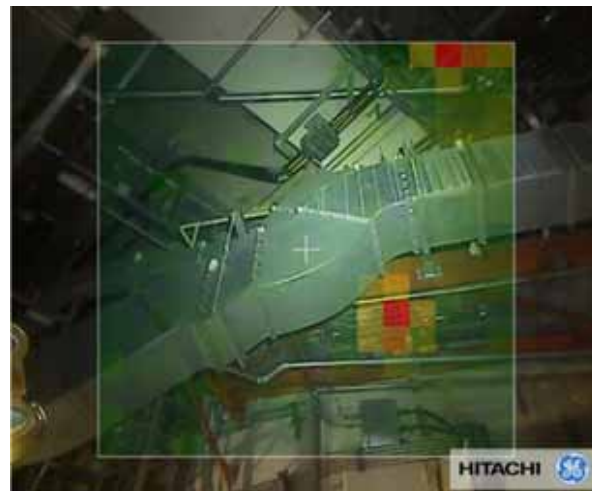

X-100B penetration (Unprocessed)



X-100B penetration (Processed)