

Permanent installation of a power panel (P/C 1D-2) in Unit 1 Seawater Heat Exchanger Building (December 27)

The power panel (P/C 1D-2) damaged by the Tsunami in Unit 1 Seawater Heat Exchanger Building was replaced with a newly manufactured power panel and has been permanently installed on December 27 after function check was completed.

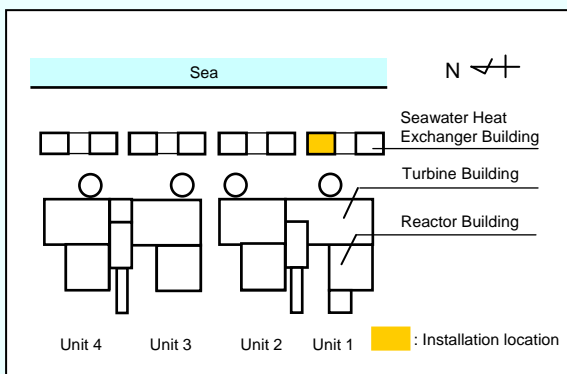

Function check [Permanent installation completed on December 27, 2012] (Photo taken on December 27, 2012)

Carry-in and installation of the auxiliary facilities of emergency diesel generator (A system) in Unit 1 Reactor Building Annex (December 12)

As for the emergency diesel generator (A) which was damaged by the Tsunami in Unit 1 Reactor Building Annex, the newly manufactured auxiliary facilities have been carried in and installed on December 12.

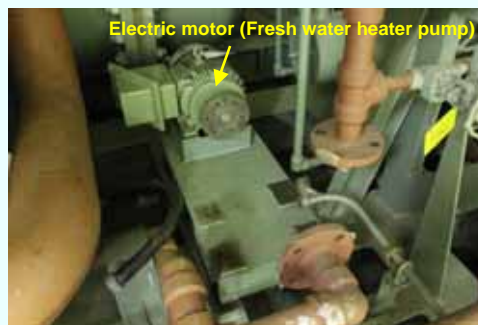
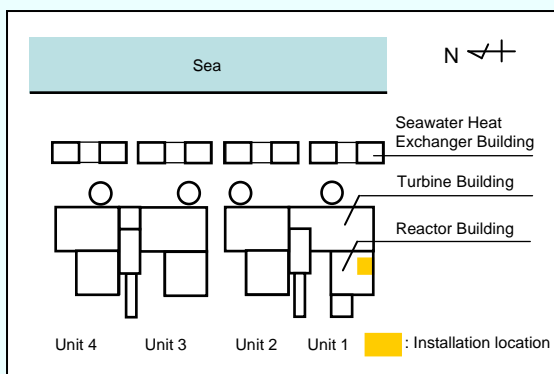

Electric motor installation (Fresh water heater pump*1) (Photo taken on December 11, 2012)



Electric motor installation (Oil pump for diesel engine valve system*2) (Photo taken on December 14, 2012)

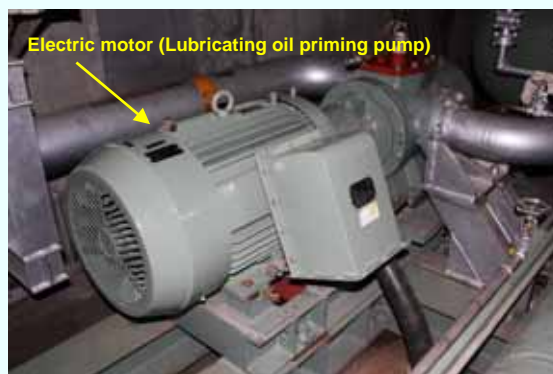

Electric motor installation (Lubricating oil priming pump*3) [Installation completed on December 12, 2012] (Photo taken on December 14, 2012)

*1 Fresh water heater pump: Used for cooling the high temperature parts of the diesel engine such as the cylinder.

*2 Oil pump for diesel engine valve system: Used for feeding lubricating oil to the sliding portion of the diesel engine valve system (Suction/exhaust valves and the link mechanism to open and close these valves).

*3 Lubricating oil priming pump: Used for feeding lubricating oil to the piston, main bearing, generator bearing, etc. while the diesel engine is suspended (in stand-by state)

Carry-in and installation of the charger and battery for the DC power supply (H system) in Unit 1 Reactor Building Annex (December 18)

As for the charger and battery for the DC power supply (H system) which were damaged by the Tsunami in Unit 1 Reactor Building Annex, the newly manufactured charger and battery have been carried in and installed on December 18.

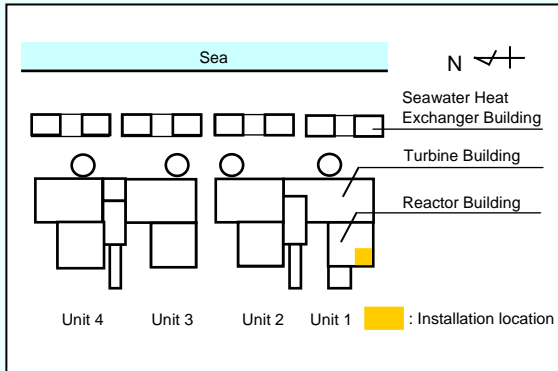

Charger (Main generating line panel) being carried in (Photo taken on November 21, 2012)



Charger panel installation
[Installation completed on December 3, 2012]
(Photo taken on December 25, 2012)



Battery installation
[Installation completed on December 18, 2012]
(Photo taken on December 25, 2012)

Carry-in and installation of the electric motor of the high pressure reactor core spray system component cooling system in Unit 1 Seawater Heat Exchanger Building (December 13)

The electric motor of the high pressure reactor core spray system component cooling system which was damaged by the Tsunami in Unit 1 Seawater Heat Exchanger Building was replaced with a newly manufactured one. The new electric motor has been carried in and installed on December 13.

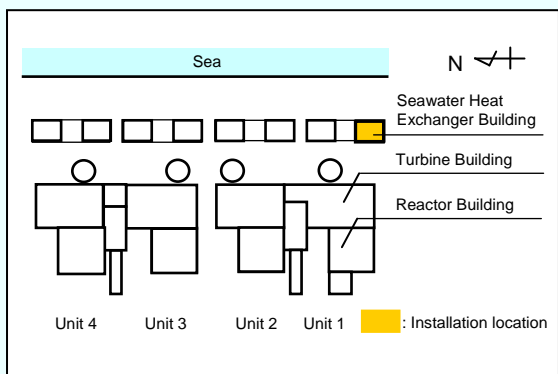

Electric motor installation [Completed on December 13, 2012] (Photo taken on December 13, 2012)

Installation of the electric motor of the high pressure reactor core spray system component cooling seawater system in Unit 1 Seawater Heat Exchanger Building (December 26)

The electric motor of the high pressure reactor core spray system component cooling seawater system which was damaged by the Tsunami in Unit 1 Seawater Heat Exchanger Building was replaced with a newly manufactured one which has been installed on December 26.

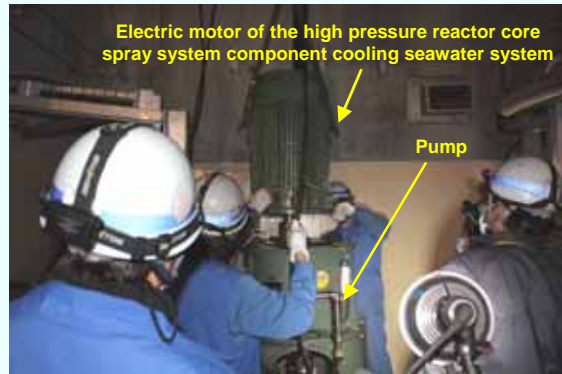
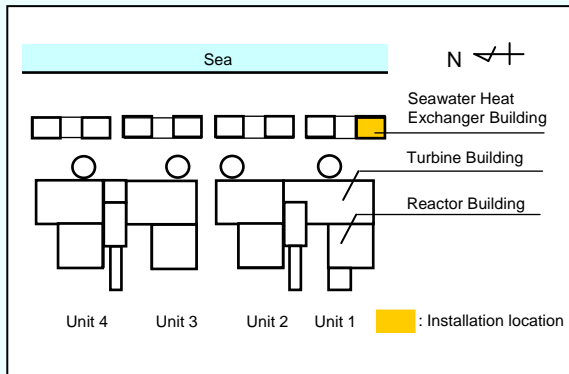

Electric motor installation [Completed on December 26, 2012]
(Photo taken on December 26, 2012)

Permanent installation of the emergency gas treatment system (A system) in Unit 1 Reactor Building Annex (December 14)

After the power panel (P/C 1C-1) in Unit 1 was permanently installed, power supply was provided to the electric motor of Unit 1 emergency gas treatment system (A system) on December 14. As the electric motor was confirmed to operate properly as a result of trial operation, Unit 1 emergency gas treatment system (A system) has been permanently installed.

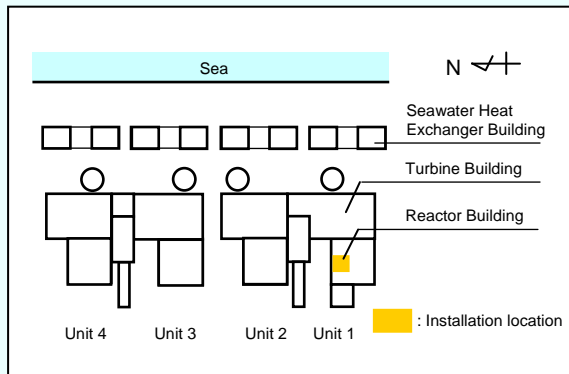

Vibration measurement being performed on the electric motor of the emergency gas treatment system (A)
[Permanent installation completed on December 14, 2012]
(Photo taken on December 14, 2012)

Permanent installation of a power panel (P/C 2D-2) in Unit 2 Seawater Heat Exchanger Building (December 25)

The power panel (P/C 2D-2) which was damaged by the Tsunami in Unit 2 Seawater Heat Exchanger Building was replaced with a newly manufactured power panel. After functional check was completed, the new power panel has been permanently installed on December 25.

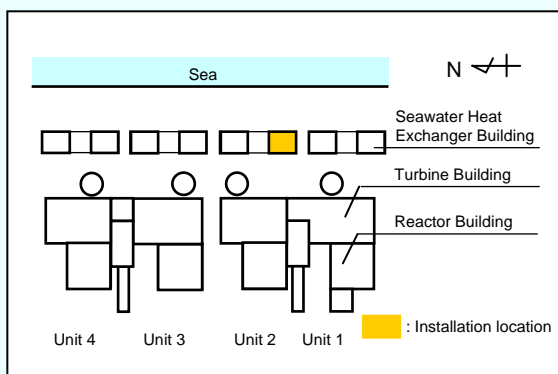

Function check [Permanent installation completed on December 25, 2012] (Photo taken on December 25, 2012)

Carry-in and installation of Units 1-2 discharge channel monitor (common facility) (December 10)

Units 1-2 discharge channel monitor which was damaged by the Tsunami was replaced with a newly manufactured one. The new discharge channel monitor has been carried in and installed on December 10. A function check is to be performed.

Overview of the discharge channel monitor

Function

The discharge channel is where the cooling water (seawater) used for transforming the steam generated in the reactor back to water, liquid waste (cleaning waste liquid, shower waste liquid, excessive plant water, etc.) and rainwater is discharged. The discharge channel monitor is installed at each discharge channel to measure the radiation dose of the liquid being discharged.

Radiation dose measurement

Seawater is continuously pumped up from the discharge channel and measured by the detector installed inside the Discharge Channel Monitor Building. The measurement results are recorded through the control board. After the measurement is done, the seawater is returned back to the water intake channel.

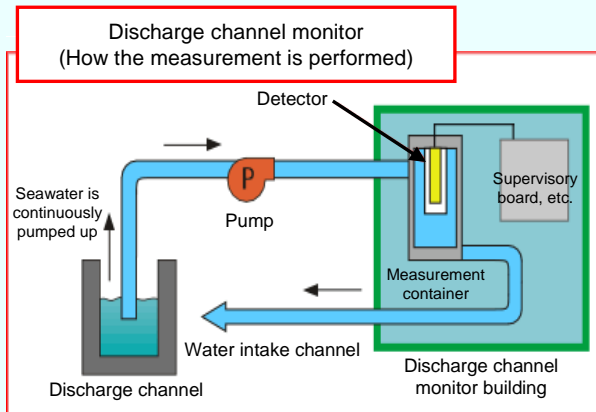
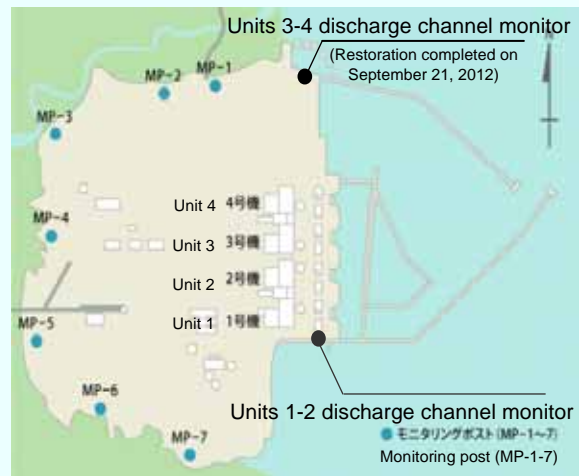

Units 1-2 discharge channel monitor (detector) installation (Photo taken on December 18, 2012)



Installation of power panel of Units 1-2 discharge channel monitor (Photo taken on December 18, 2012)



Installation of supervisory board, etc. of Units 1-2 discharge channel monitor [Installation completed on December 10, 2012] (Photo taken on December 18, 2012)