

Evaluation of integrity of suppression chamber at Unit-2

1. Background

Unit-2 was successfully depressurized at 18:02 on March 14th (2011) by the manual opening operation of main steam safety relief valves (SRVs). It was recorded that another SRV was opened upon reactor pressure increase at around 21:00 on March 14th, but the reactor pressure did not decrease; and that another SRV activation could decrease the reactor pressure at 21:20. Attachment 2-7 reviews the scenario which suggests a possibility that the repeated increase and decrease of reactor pressure over this time period could have happened even without SRV activations. In the meantime, at 21:20 on March 14th, when the reactor pressure decrease was observed, a rapid pressure increase of the containment vessel (D/W) was confirmed. Therefore, it is highly likely that the SRV actually functioned at this time and the gas remaining in the RPV was instantly discharged to the suppression chamber (S/C) and raised the containment vessel (D/W) pressure.

The reactor pressure at about 21:00 on March 14th, when it increased, was about 1.5MPa. At this time, the core damage is considered to be already ongoing. Therefore, the steam discharged upon reactor depressurization would have contained a lot of non-condensable gas, hydrogen. The reactor pressure changes might have been different in their increasing behavior due to the presence of non-condensable gas from those due to the presence of only steam. The issue of possible impacts on the S/C integrity is designated as Unit-2/Issue-10.

This document presents examination results about the possible impacts of instantaneous discharge of hydrogen-rich steam into the S/C from SRVs on the S/C integrity.

2. Estimation to Locate the S/C damage of Unit-2

2.1. Current estimation about the damage location for the S/C of Unit-2

Unlike Unit-1 and Unit-3, direct leaks from the Unit-2 PCV have not been located. But it is clear that leaks took place somewhere, since the water level in the PCV remained low while water was continuously injected to the reactor. Examination up to now suggests a high possibility that, as illustrated in Figure 1, the leak took place at a lower position of the S/C or from a line connected to the lower part of the S/C (Attachment 4). Figure 1 also shows the current S/C water level measured and the water level in the torus room where the S/C is installed.

Figure 2 gives the temperature distribution measured in the Unit-2 S/C [1]. Unlike Unit-1 and Unit-3, the temperature distributions in the Unit-2 S/C can be seen as very characteristic: Vapor phase thermometers showed relatively high values, while liquid phase thermometers showed lower values.

[1] Possible approaches for grasping plant situations, Technical Workshop for the Accident of

the Fukushima Daiichi Nuclear Power Plant, Nuclear and Industrial Safety Agency, July 23rd and 24th, 2012

2.1.1. Deliberations on temperature changes in late June 2011

A big decrease was seen in the vapor phase temperatures in late June (② in Figure 2). This corresponds to the timing after the nitrogen gas injection was started on June 28th, 2011. Since no heat source exists in the S/C, its temperature changes subject to the energy supply from the D/W. Before the nitrogen gas injection, steam would be condensed at the positions at relatively lower temperatures such as at the S/C walls and a big amount of steam would have been flowing into the S/C from the D/W. That means, while only steam was flowing into the S/C from the D/W, the steam volume was instantly reduced by condensation, causing a pressure decrease at that area and a large amount of steam flow from a high pressure space (D/W) to a lower pressure space (S/C). Upon injection of nitrogen gas, a gaseous mixture of steam and nitrogen flowed into the S/C. Since nitrogen gas does not condense, the volume change by condensation was reduced. The pressure decrease was also reduced, and consequently the amount of steam into the S/C was also reduced. Since the S/C temperature is subject to the energy supply from the D/W, the S/C temperature decreased. The temperature decrease at ② would have been thus caused.

On the other hand, the liquid phase thermometers did not show such a big temperature decrease. They certainly would have been measuring the temperature of water phase in the S/C.

Figure 3 illustrates the geometric configuration of the D/W-S/C connection. The figure also shows the water levels when the water level in the D/W was assumed high. If the water level in the D/W is high enough, the venting line between the D/W and the S/C is filled with water and no direct steam flow takes place from the D/W to the S/C. In order for the steam to flow directly to the S/C from the D/W, the D/W water level must be low enough so that water may descend into the venting line. Therefore, the measured D/W water level (shown in Figure 1) was consistent with the situation of observed temperature changes (shown in Figure 2). It was also likely that the D/W water level was this low from a fairly earlier timing when the injected water started to leak out to the containment vessel due to the RPV damage.

2.1.2. Deliberations on temperature changes in late March 2011

Before the end of March (time point ① in Figure 2), both the vapor phase and liquid phase thermometers showed almost identical readings. As seen in 2.1.1 above, water temperatures and gas temperatures should change with different behavior, i.e., before time point ①, both thermometers seemed to have measured either water temperatures or gas temperatures. At time point ①, readings of two thermometers started to deviate from each other and the liquid phase thermometers showed steeper changes. This may indicate the following: Taking the continuity of temperature changes into consideration, it seems likely that both vapor phase and liquid phase thermometers were above the water surface, as illustrated in Figure 4, until the end of March.

Since the water surface level at this time point was significantly lower than the normal level, this suggests a possibility that a good amount of S/C water inventory, existent before the accident, would have been, including the water being injected after the accident, discharged to the outside. Part of the highly contaminated water found in the turbine building after the accident might have been included in the contaminated water thus discharged from the S/C to the outside.

To sum up, the S/C water level started to rise from around the end of March and at time point ① the water seemed to have reached the level high enough to immerse the liquid phase thermometers. .

2.1.3. Deliberations on temperature changes after September 2011

An increase appeared in the S/C temperatures after water injection to the reactor started on September 14th using the core spray (CS) system. The CS injected water directly to the inner side of the RPV shroud. This means the water reached the reactor through a path different from the earlier path, i.e., through outside the RPV shroud using the low pressure coolant injection (LPCI) system or feedwater (FDW) system. As a result, the injected water reached some part of the fuel debris which had not been directly cooled. The water injected through the CS thus removed heat from the overheated debris and transferred its energy to the S/C as steam or hot water. This energy transfer can be considered to have caused the S/C temperature increase after September.

After October both vapor phase and liquid phase thermometers occasionally gave the same readings. As discussed earlier this indicates both thermometers were either underwater or in the gaseous phase.

It is not clearly known yet in which phase (water or gas) these thermometers were at these occasions. At least it seems sure the water level was changing up and down with reference to the elevation of thermometers.

It is logical that the water level is staying above the elevation of a leak position when the water level decreases by leaking out. In consequence, the leak position of Unit-2 S/C was estimated to be at a lower location, as illustrated in Figure 1.

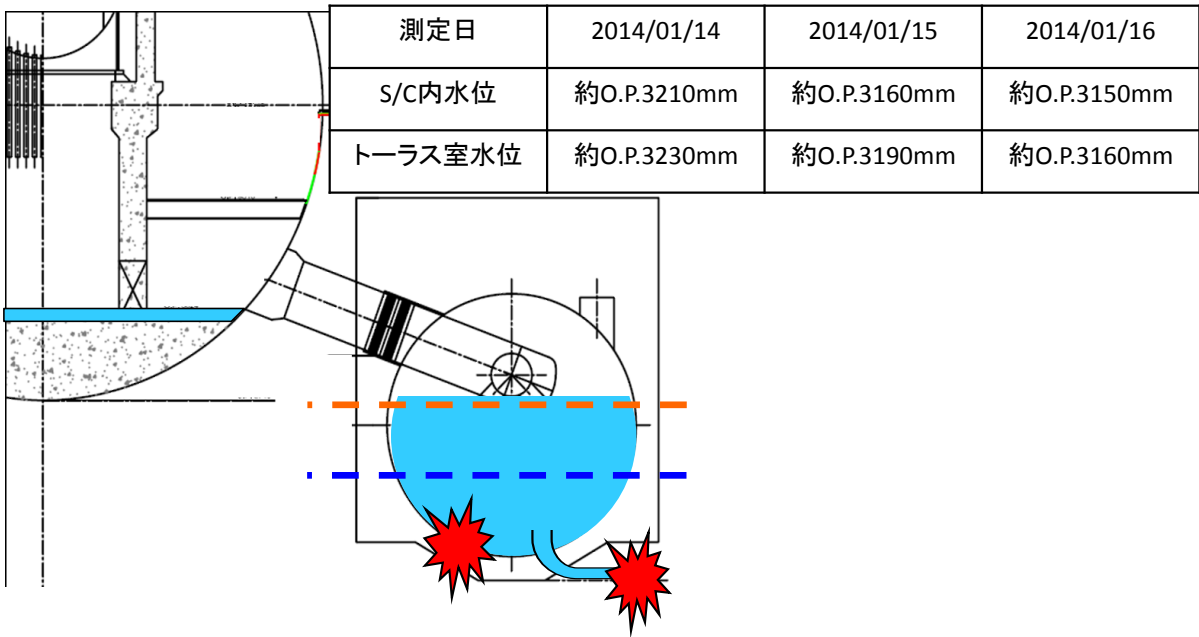

測定日	Date of measurement
S/C 内水位	S/C water level
トールス室水位	Water level in the torus room

Figure 1 Water levels in Unit-2 CV and estimated location of leaks

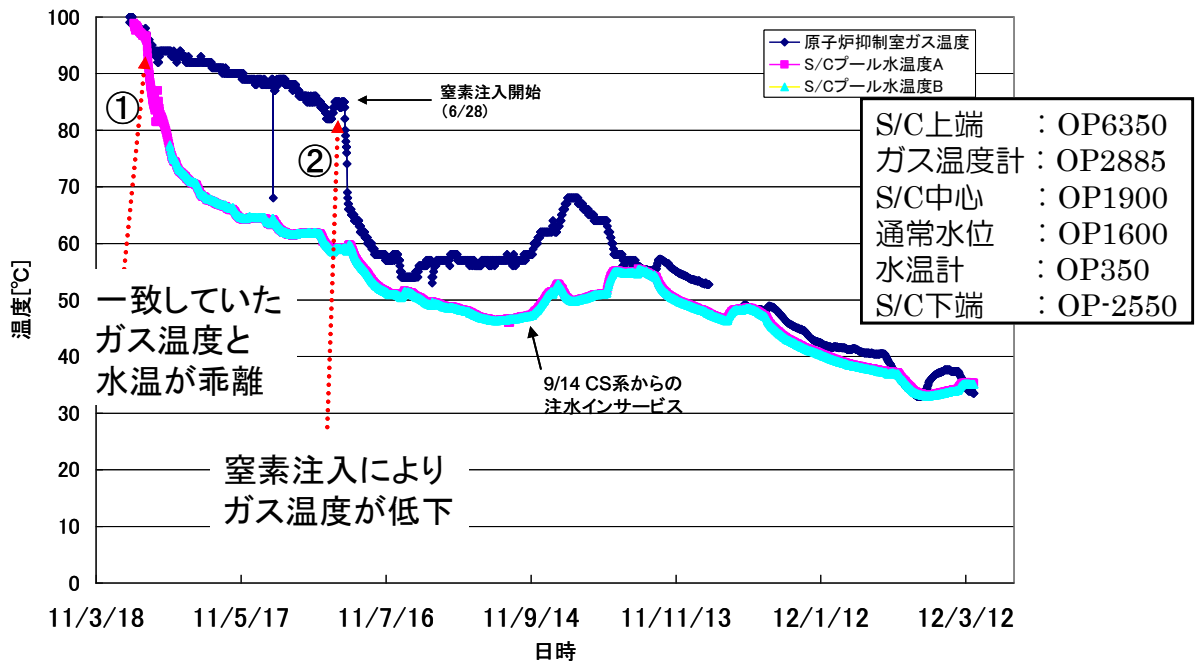

一致していたガス温度と水温が乖離	Gas/water temperatures started to deviate
窒素注入によりガス温度が低下	Gas temperature decrease due to injected nitrogen gas
窒素注入開始	Nitrogen gas injection starts
CS系からの注水インサースビス	Water injection by CS starts
圧力抑制室ガス温度	S/C gas temperatures
S/C プール水温度 A	S/C pool water temperatures A
S/C プール水温度 B	S/C pool water temperatures B
S/C 上端	S/C upper end
ガス温度計	Vapor phase thermometer
S/C 中心	S/C center
通常水位	Normal water level
水温計	Liquid phase thermometer
S/C 下端	S/C bottom end
日時	Year/month/day

Figure 2 Thermometer readings in Unit-2 S/C

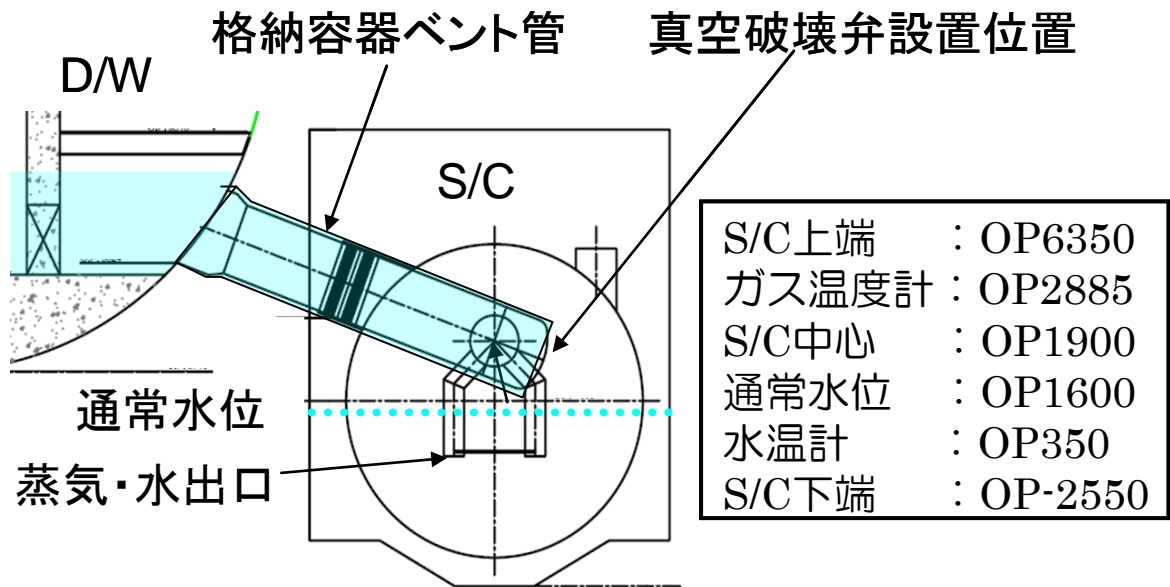

格納容器ベント管	PCV venting line
真空破壊弁設置位置	Vacuum breaker valve location
通常水位	Normal water level
蒸気・水出口	Steam/water outlet

Figure 3 D/W – S/C configuration (when the D/W water level is high)

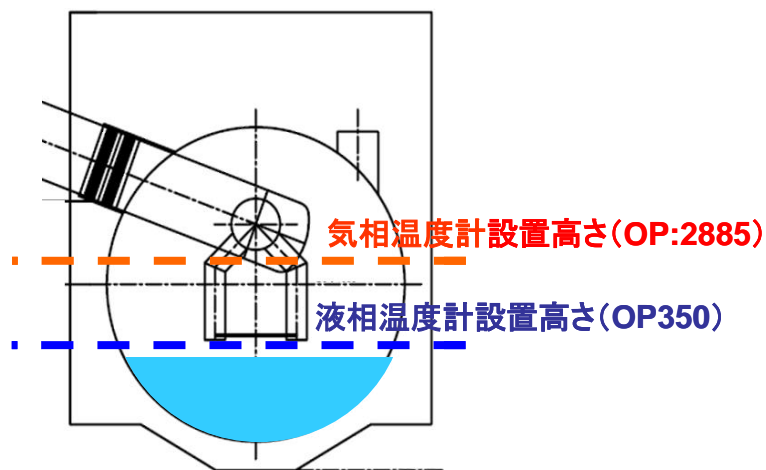

気相温度計設置高さ	Vapor phase thermometer location
液相温度計設置高さ	Liquid phase thermometer location

Figure 4 Estimated S/C water levels before the end of March

2.2. Deliberation on the S/C integrity

2.2.1. Damage to vacuum breakers

Section 2.1 above reviewed the results obtained so far concerning the S/C water level issue.

This section reviews the issue of integrity of the S/C internals, based on the temperature changes shown in Figure 2.

As discussed in 2.1.1 above, no steam directly flows into the S/C from the D/W, when the D/W water level is high enough. Even if steam flows in, it reaches the S/C through the tip (OP325) of the inverse U-type line as far as the design value is concerned, as seen in Figure 3. Since the current S/C water level is at a higher elevation above the vapor phase thermometers, both thermometers give the water temperatures, and no steam from the D/W flows directly into the S/C.

On the other hand, the situation after the end of March (2011) is considered as in the following: the liquid phase thermometers were under water, the vapor phase thermometers were in the gaseous phase, and steam was directly flowing into the S/C from the D/W. The elevation difference between the liquid phase thermometers and the steam outlet to the S/C at the tip of the inverse U-type line is very subtle, as illustrated in Figure 4. As soon as the water level increases and immerses the liquid phase thermometers, the steam outlet would be blocked almost simultaneously. However, the observed data indicated that the direct steam flow to the S/C still continued. This indicates a possibility that steam had been leaking to the S/C through a position different from the steam outlet determined by design.

Steam flow from the D/W to the S/C is designed to proceed underwater. This is so designed because, upon unusual steam generation in the D/W, the steam is to be led to the S/C for condensation, thus suppressing the PCV pressure increase. This is a matter of fact, as the Mark-I PCV is called a suppression chamber type PCV. However, if the condensation decreases the D/W pressure below the S/C pressure, the steam cannot be returned to the D/W. To let the steam in the S/C return to the D/W, a valve is installed, that is the vacuum breaker shown in Figure 3. The vacuum breaker is installed on the tip of the PCV venting line, normally in the gaseous phase. The vacuum breaker is designed to allow the flow only from the S/C to the D/W, not in the opposite direction. But if this were broken, steam could flow constantly from the D/W to S/C.

It can be estimated from the deliberations above together with the temperature changes in the Unit-2 S/C that one or more of the vacuum breakers installed on the Unit-2 S/C (16 of them had been installed in total) could have been damaged.

In the Unit-2 accident progression, possible cases of overpressure to the vacuum breakers could be (1) the rapid D/W pressure increase which might have been caused by the SRV opening operation noticed during the night of March 14th, 2011, as mentioned in Section 1 Background; or (2) deterioration of seal materials due to seawater injection or high temperature environment of the containment vessel. However, it is difficult to identify the reason as of now why the vacuum breakers lost the functions (inverse flow).

3. Summary

Examination has been done into the S/C integrity and leak location, based on the data observed at the time of the accident and the temperatures observed thereafter. In addition, steam flows from

the D/W to S/C were reviewed and a possibility of damage of vacuum breakers was examined.

- The changes in readings of vapor phase thermometers and liquid phase thermometers installed in the S/C reflect the S/C water level changes;
- It is possible that the S/C water level decreased to a fairly low level in the wake of the accident. The Unit-2 S/C might have been the source of contaminated water, which became clearly recognized from late March;
- The Unit-2 S/C water level changes are consistent with the water level changes in the torus room. Therefore, the leak hole is likely to exist at a lower position;
- From the relative geometrical configuration of the D/W and S/C, only low D/W water levels can explain the phenomena observed; and
- Vacuum breakers installed in the Unit-2 S/C might have possibly been damaged. The rapid increase of containment vessel pressure upon SRV activation at 21:00 on March 14th, 2011 could have been due to such damage.