

Status of investigation on estimating situation of cores and containment vessels

1. Introduction

The conditions of Unit-1 and Unit-3 containment vessels (PCVs), and the situation of damaged and fallen fuel were estimated, at a technical workshop held on November 30, 2011, based on comprehensive evaluation of then-available knowledge, such as temperature changes, etc. due to water injection by the core spray systems. The workshop (organized by the former Nuclear Industry and Safety Agency) was for estimating the conditions of core damage at Unit-1 to Unit-3 of the Fukushima Daiichi Nuclear Power Station.

Thereafter, TEPCO has continued estimating core and in-containment conditions and updated them by incorporating accumulated knowledge. Since JFY2016, the estimation of fuel debris distribution at Unit-1 to Unit-3 has been undertaken in collaboration with a government subsidized project of “Decommissioning and Contaminated Water Management (Upgrading Level of Grasping State inside Reactor)” being managed jointly by the International Research Institute for Nuclear Decommissioning (IRID) and the Institute of Applied Energy (IAE).

The latest illustrations for the estimated situations in cores and containment vessels incorporating new knowledge obtained thereafter by the results of accident progression analysis, field investigations, etc., are summarized in Figures 1-1 to 1-3 (the outcomes of the above Project).

This Attachment presents the information added to the estimations of the illustrations as of November 30, 2011.

Refer to Chapter 9 of the Main Body of Progress Report for the usage of O.P.

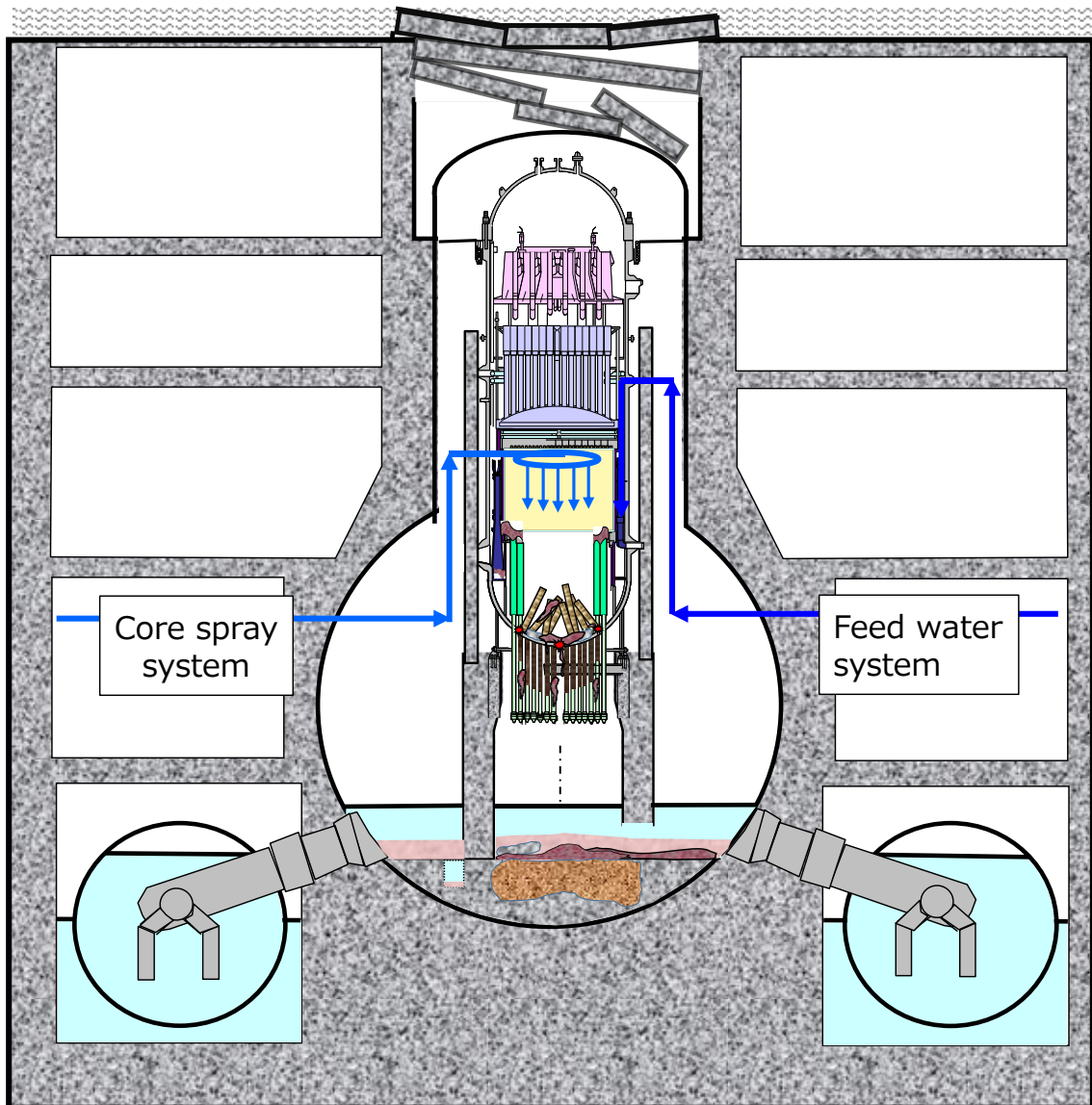

Legend

- |                          |                     |                                   |
|--------------------------|---------------------|-----------------------------------|
| Oxidized debris (porous) | Debris as particles | Concrete mixed debris             |
| Intact CRGT              | Damaged CRGT        | Intact CRD                        |
| CRD (debris inside)      | Intact shroud       | Sediments (material unidentified) |
| RPV hole due to damage   |                     |                                   |

Figure 1-1 Estimated conditions of the core and PCV of Unit-1

(Note) This figure is an image and does not represent the quantitative fuel debris conditions

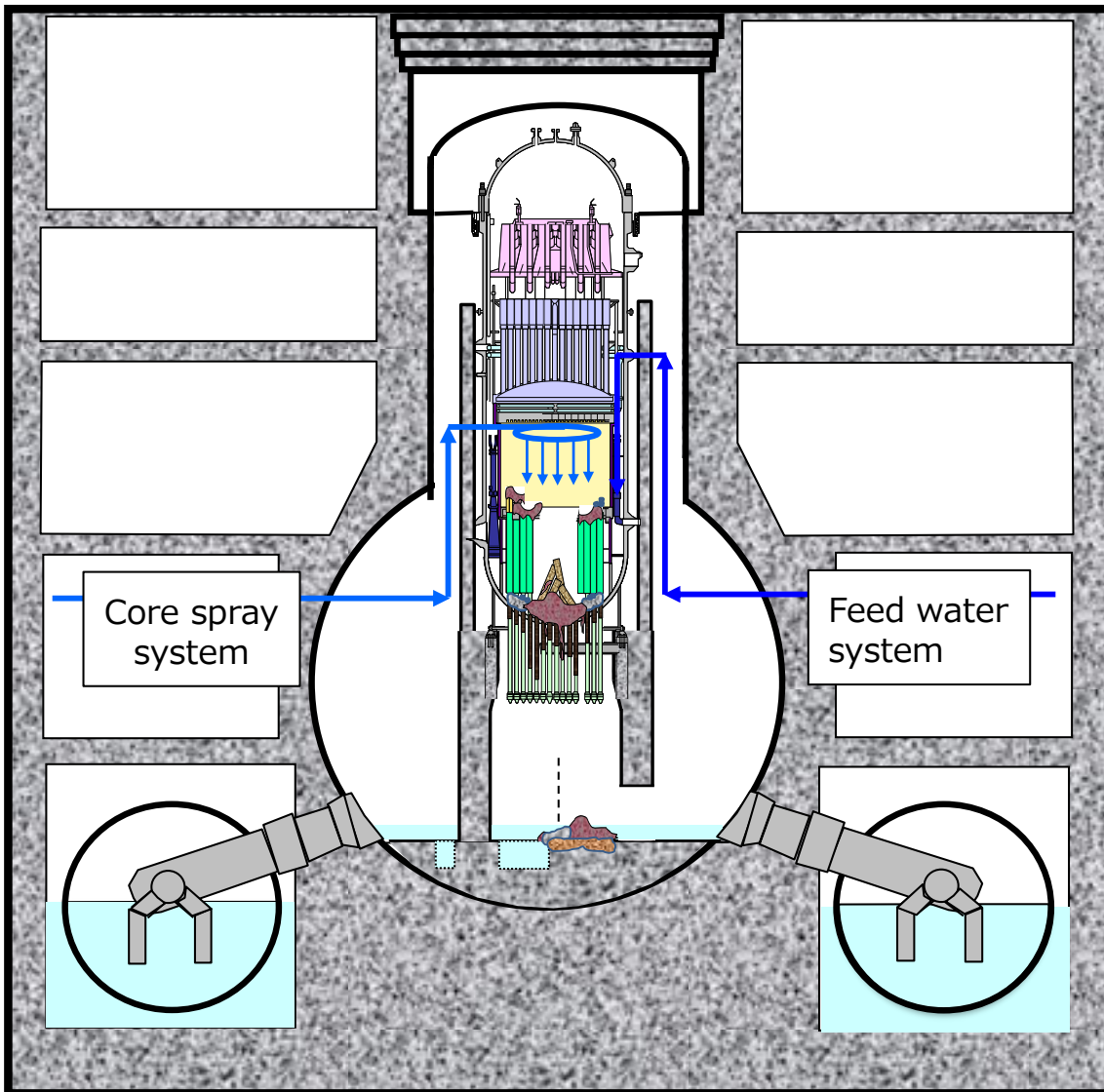

Legend











- |   |  |   |
|---|--|---|
|  Fuel rod              |  Oxidized debris (porous) |  Debris as particles |
|  Concrete mixed debris |  Intact CRGT              |  Damaged CRGT        |
|  Intact CRD            |  CRD (debris inside)      |  Intact shroud       |
|  Pellet                |  |   |

Figure 1-2 Estimated conditions of the core and PCV of Unit-2

(Note) This figure is an image and does not represent the quantitative fuel debris conditions



Legend

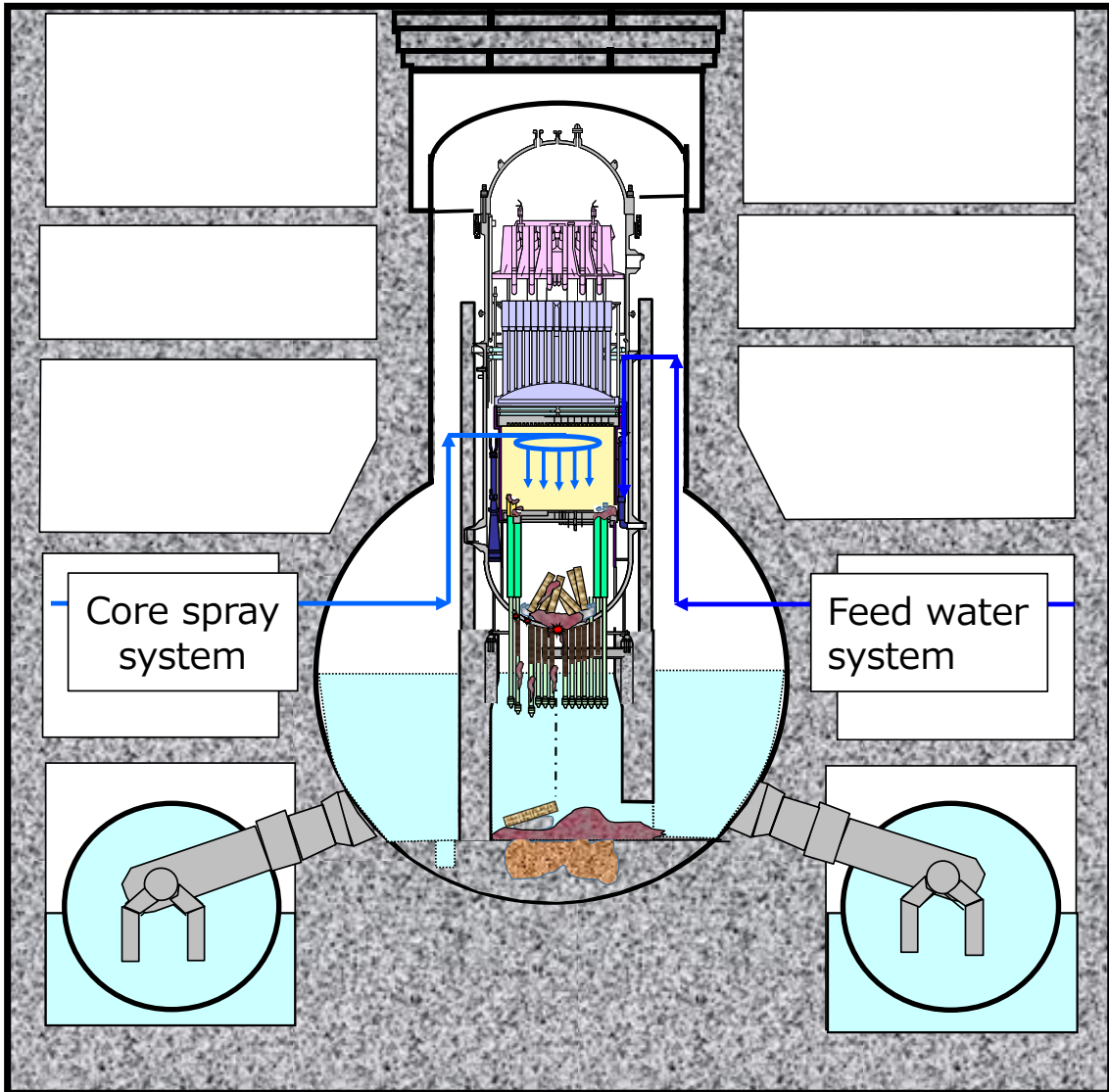









- |   |  |   |
|---|--|---|
|  Fuel rod              |  Oxidized debris (porous) |  Debris as particles |
|  Concrete mixed debris |  Intact CRGT              |  Damaged CRGT        |
|  Intact CRD            |  CRD (debris inside)      |  Intact shroud       |
|  Pellet                |  RPV hole due to damage   |   |

Figure 1-3 Estimated conditions of the core and PCV of Unit-3

(Note) This figure is an image and does not represent the quantitative fuel debris conditions

2. Conditions of Unit-1 core and PCV

(1) In-containment water level measured

In October 2012, an investigation was conducted into the status of the PCV of Unit-1, when photos were taken by cameras, the level of water retained in the PCV was confirmed, dose rates and temperatures were measured, and retained water was sampled and analyzed [1] by inserting survey devices into the containment through a hole dug at the PCV penetration (X-100B, on the first floor of the reactor building).

The level of water retained was measured by lowering the CCD camera cable down to the water surface through the grating above in the PCV. The water level was found to be about 2.8m above the D/W floor (as of October 10, 2012) (Figure 2-1).

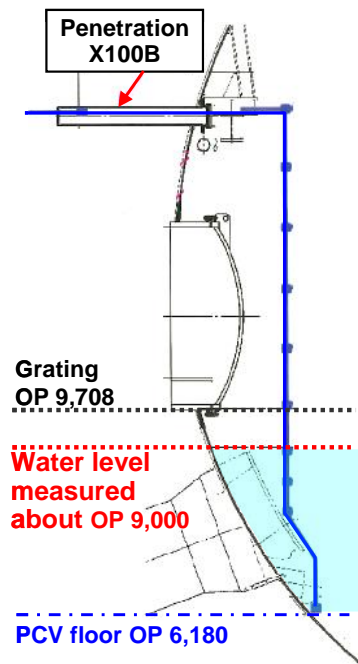

Figure 2-1 Measured level of water retained in Unit-1 PCV

(2) Test results of injecting nitrogen gas into the suppression chamber of Unit-1

In September 2012, a nitrogen gas injecting test was conducted into the suppression chamber (S/C), in which the theory was demonstrated that hydrogen gas and Kr-85 generated in the early stage of the accident and retained in the S/C upper space pushed down the S/C water level and were discharged to the D/W through the vacuum breakers. This helped to confirm that the S/C was currently almost filled with water (the level at around the lowest end of the vacuum breaker tube [2] (Figure 2-2).

This test was conducted with an intention to explain the phenomenon of the intermittent increase of hydrogen gas concentration and Kr-85 radioactivity measured by the containment gas control system of Unit-1 that has been seen since April 2012. This intermittent increase was assumed to occur in the following sequence: When the S/C water

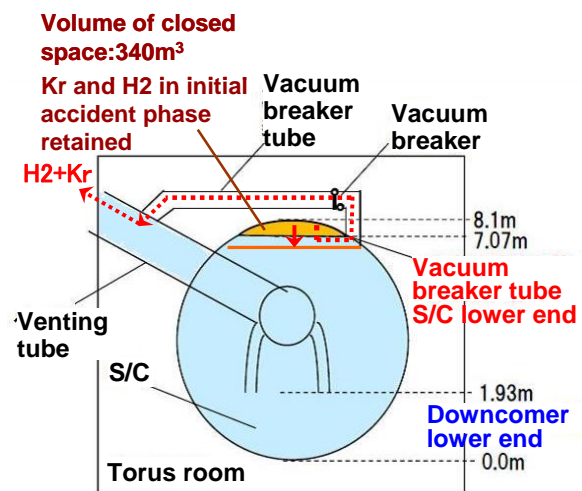

Figure 2-2 Closed space in gaseous phase inside S/C of Unit-1

[1] Handout document, 11th Steering Committee, Government – TEPCO Joint Board on Mid- and Long-term Response Policy, October 22, 2012

[2] Handout documents, 9th and 10th Steering Committees, Government – TEPCO Joint Board on Mid- and Long-term Response Policy, August 27 and September 24, 2012

level drops, residual gas left in the closed space in the upper S/C is discharged to the D/W through vacuum breakers, and then the S/C water level rises and stops the gas discharge. In this hypothesis, Kr-85 is understood to originate in the early phase of the accident, because Kr-85 is a long half-life fission product and its amount cannot be explained as being newly produced by spontaneous fission, etc.

In the test to verify the mechanism hypothesis, the S/C pressure (being monitored by the existing instrumentation) rose after the injection of nitrogen gas started into the S/C, the hydrogen gas concentration and Kr-85 radioactivity monitored by the containment gas control system started to increase, which decreased when nitrogen gas injection was halted. This is interpreted to be that the nitrogen gas injection pressurized the closed space of the S/C upper part, which lowered the S/C water level and formed a gas discharge channel to the D/W through the vacuum breakers, thus the retained gas in the space was discharged together to the D/W by the injected nitrogen gas.

Most of the hydrogen gas retained in the S/C has been purged by continuously injecting nitrogen gas into the S/C since October 2012. Further tests are now underway to verify a mechanism of hydrogen production in the S/C by water radiolysis.

(3) Investigation of the torus room of Unit-1

The torus room was investigated in February 2013, when photos were taken by cameras, dose rates and temperatures were measured, and retained water was sampled and analyzed by inserting thermometers, dosimeters and cameras through a  $\phi$  200 hole dug on the northeast corner on the first floor of the reactor building [3].

No water leaking position in the S/C has been located yet. At least, no leak was confirmed on the flange of one of the eight vacuum breakers, as far as the camera photos showed (Figure 2-3).



Figure 2-3 Camera photo of an S/C vacuum breaker in the torus room of Unit-1

(4) Investigation of the situation at the bottom of the vent tubes in the torus room of Unit-1

In the torus room investigation in November 2013, a compact automated instrumentation boat, on which a camera and dose meters were mounted, was lowered into the torus room through a

---

[3] Handout document, Progress in preparations for decommissioning of Units-1 to 4 of the Fukushima Daiichi Nuclear Power Plant, Decommissioning Measures Steering Panel, March 7, 2013

510 mm diameter hole drilled into the flooring of the first floor of the Unit-1 reactor building in the northwest corner. The boat was lowered to check visually for water leaks from the vent tube sleeve terminals, to check visually the condition of the sand cushion drain tubes, and to make dose measurements [4].

Camera imaging confirmed water leaks at the following locations (Figure 2-4).

- Vent tube X-5B (① in the figure): water flowing from the displaced sand cushion drain pipe\*
- Vent tube X-5E (④ in the figure): water flowing down on the S/C surface with 2 streams around both sides of the vent tube

\*Water leaks at ① were confirmed since the vinyl chloride pipe (connecting the sand cushion drain tube and drain funnel with an insertion-type joint) had been displaced. Water leaks could not be confirmed at locations ② to ⑧, since the drain tubes had not been displaced. The concrete seams (joints) below the sand cushion drain piping were observed to be wet all around on the concrete wall.

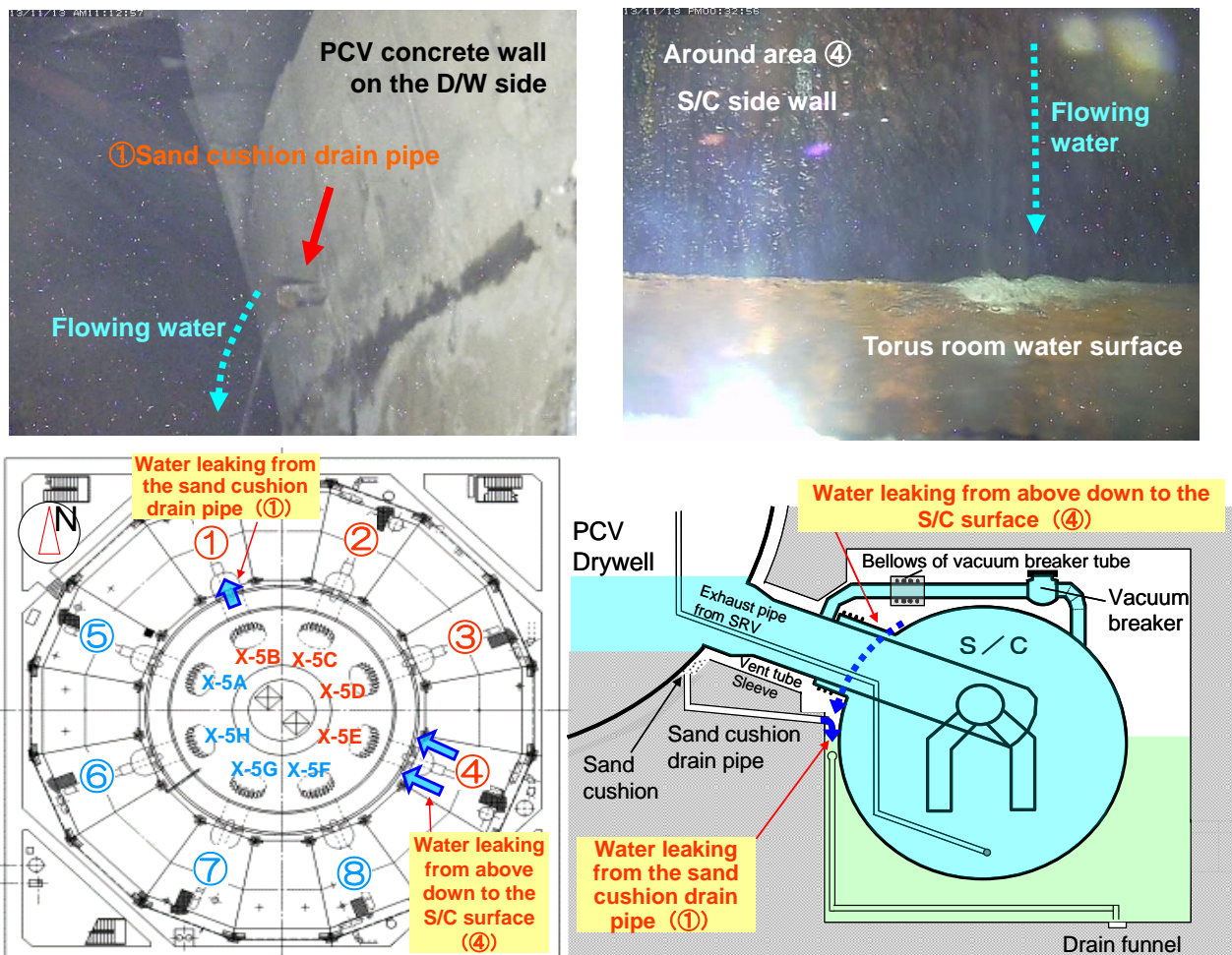

Figure 2-4 Camera images taken below the vent tubes in Unit-1 torus room (part)

[4] Handout document, Progress in preparations for decommissioning of Units 1 to 4 of the Fukushima Daiichi Nuclear Power Station, 10th Decommissioning Measures Steering Panel, November 28, 2013

Water leaks into the sand cushion occur only when water leaks directly from the drywell. The leakage is probably from a low position of the drywell below the water level (for example, the containment vessel shell, pipe penetrations, etc.). The low location of the water leaks in the drywell would indicate the possible influence of molten fuel that fell to the PCV bottom. This information is of critical significance in estimating the conditions of the core and PCV.

Meanwhile, the water leakage down to the S/C surface around both sides of the vent tube X-5E indicates the possibility of water leaks from the vacuum breaker tube (its bellows, for example) immediately above the vent tube. This elevation of the vacuum breaker tube is about the same level as that of the upper limit of PCV water level which was reached in an attempt to flood the PCV by increasing the amount of water injected in May 2011; where the PCV water level was calculated from the injected nitrogen gas pressure. The nitrogen gas pressure was stopped from changing at a specified level, which means the PCV water level was leveled off, i.e., an indication of leak hole existence at the level (Figure 2-5) [5].

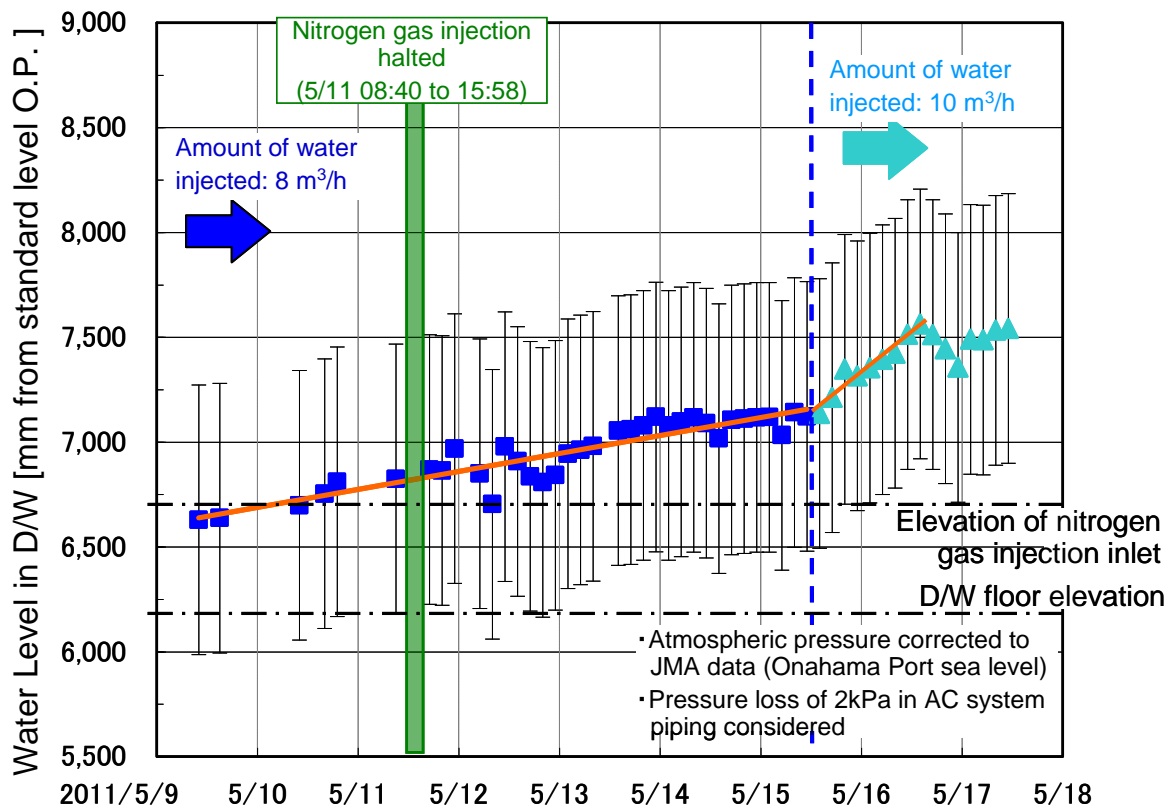

Figure 2-5 Estimated PCV water level changes during flooding operation of Unit-1 (May 2011)

The vertical distribution of radiation doses measured when lowering the instrumentation boat in November 2013 was similar to that measured in February 2013 (in the area surrounding the torus). Dose distribution along the boat traveling route was about 1 to 2 Sv/h, and the highest spots were in the southeast area (Figure 2-6).



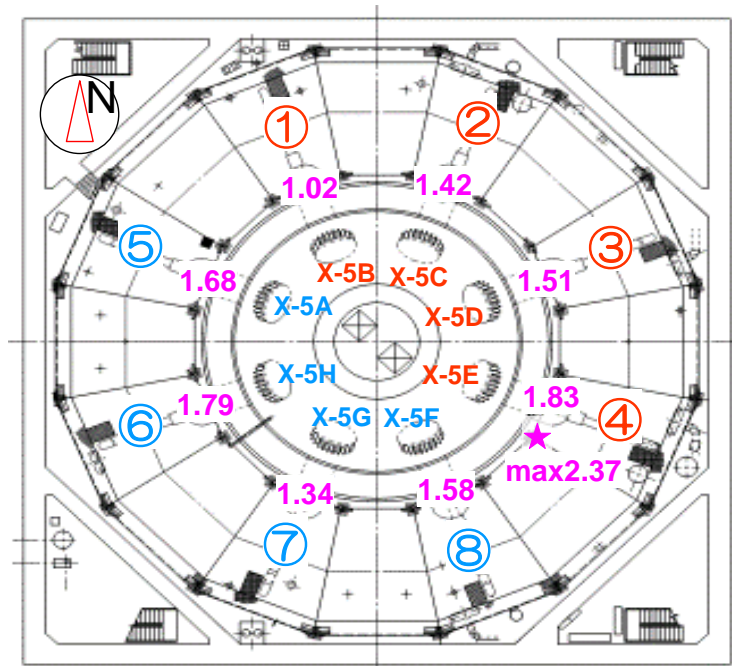

Figure 2-6 Dose distribution measured during the torus room investigation underneath vent tubes of Unit-1

In June 2011, steam blown from the pipe penetrations was witnessed at the southeast corner of the first floor of the reactor building. This would mean that radioactive materials carried by the steam were blown to the torus room after the accident and they deposited on the walls and structure surfaces there. The dose distribution in the torus room is considered to be the sum of doses due to these contamination sources. The estimated radiation dose levels on the water surface due to water-retained radionuclides ( $7.3 \times 10^4$  Bq/cm<sup>3</sup> of Cs-134 and  $1.5 \times 10^5$  Bq/cm<sup>3</sup> of Cs-137, sampled on February 22, 2013) are about 100 mSv/h and not a dominant contributor to the 1 to 2 Sv/h doses measured [6].

In May 2014, survey instrumentation robot was introduced through a drilled hole in the northwest area of the first floor of the Unit-1 reactor building to explore the S/C top area in order to locate the leak source near the vent tube X-5E, where leaking had been confirmed. By using the outer catwalk, the instrumentation robot made a camera survey around the vent tube X-5E, and the water leak was confirmed to be from the protective cover of the expansion joint on the vacuum breaker line. No leaks were noticed from the vacuum breaker valve, torus hatch, shutdown cooling system (SHC) piping or atmospheric control system (AC) piping (Figure 2-7) [7].

[6] Handout document: Consideration of dose measurement results in the torus room of Unit-1, 7th Meeting of Specific Nuclear Facilities Survey and Examination, March 29, 2013.

[7] Handout document: Consideration of dose measurement results in the torus room of Unit-1, 6th Meeting of Specific Nuclear Facilities Survey and Examination, May 29, 2014

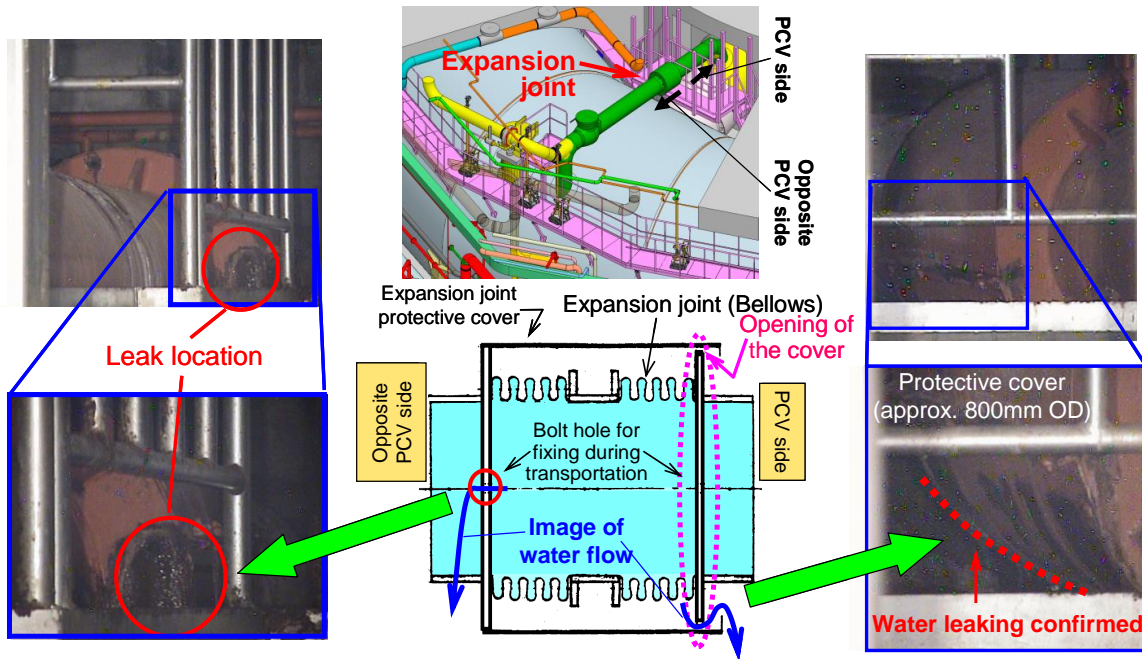

**Illustration of Expansion joint (Bellows) for vacuum breaker tube**

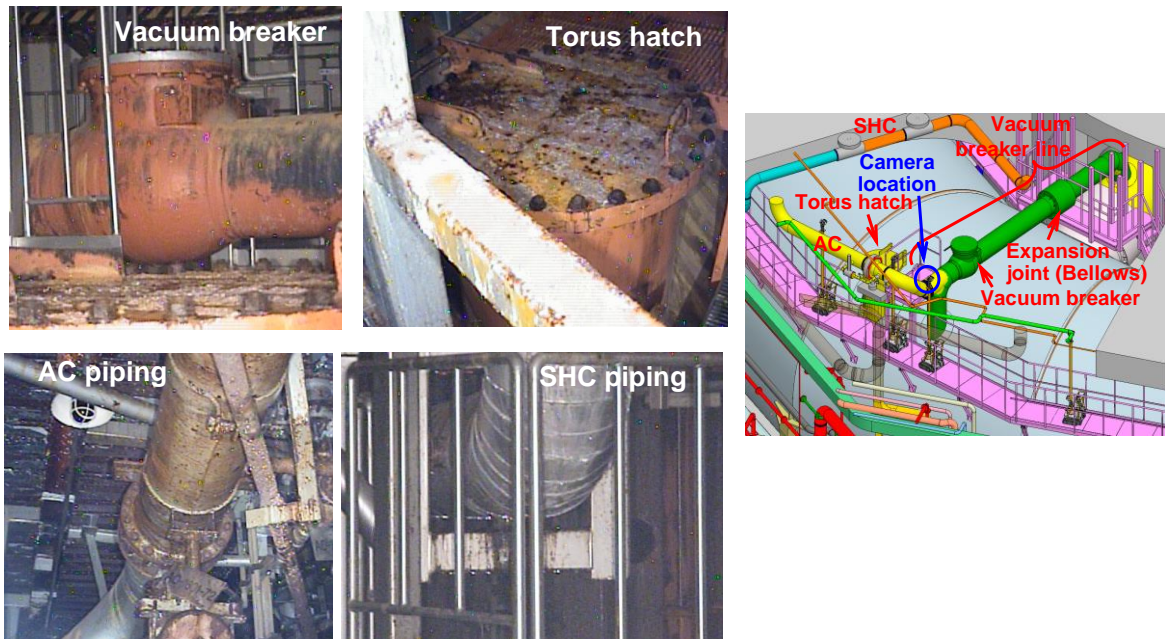

Figure 2-7 Camera images of Unit-1 S/C top area exploration (around vent tube X-5E) (Part)

(5) Contamination survey on the Unit-1 reactor building first floor

In December 2013, contamination was surveyed on the first floor of the Unit-1 reactor building by radiation dose measurements and gamma camera images taken using a robot. It was found that contamination was relatively high on the atmospheric control system (AC) piping and drywell humidity control system (DHC) piping (Figure 2-8) [8].

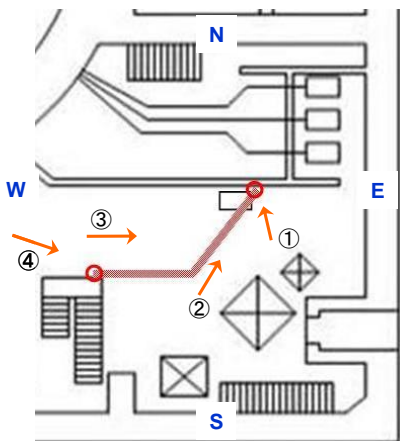

Figure 2. AC system piping route (about 2m elevation)

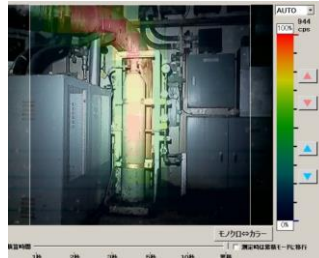

Figure 3. Photo from ①

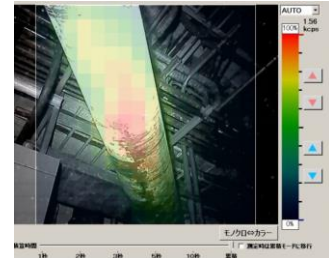

Figure 4. Photo from ②

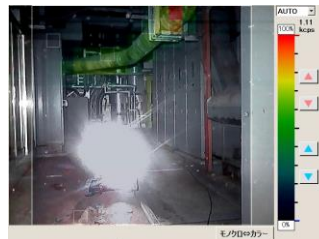

Figure 5. Photo from ③



Figure 6. Photo from ④

(Gamma camera image taken near the AC system piping in the reactor building 1st floor)

Hot spots confirmed along piping

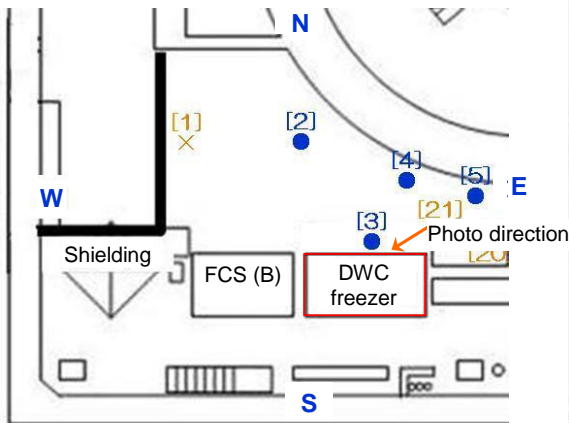

Figure 9. Layout

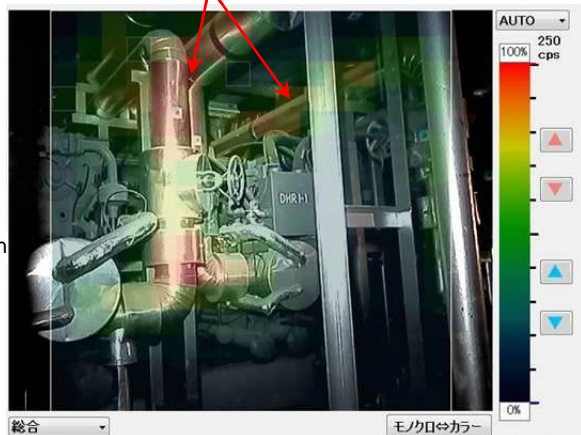

Figure 10. Gamma camera image taken near the DWC freezer

(Gamma camera image taken near the DWC system piping in the reactor building 1st floor)

Figure 2-8 Gamma camera images in the southern area of Unit-1 reactor building 1st floor (part)

The AC piping is where the steam passed through when the wetwell (WW) venting was carried out during the accident. Its high contamination is considered to be due to venting flows, and the situation was similar to that for the area near the standby gas treatment system (SGTS) train entrance room or near the SGTS piping connected to the main stack, where high dose rate had

[8] Handout document: Action progress towards decommissioning of Units 1 to 4 of Fukushima Daiichi Nuclear Power Station, 2nd Decommissioning and Contaminated Water Response Team Joint Meeting, January 30, 2014  
Attachment 4-11

been already confirmed.

The DHC piping is connected to the reactor building closed cooling water system (RCW), and therefore its high dose is considered to be due to the same mechanism as that of RCW piping, where high dose rate had been already confirmed.

(6) Investigation of the grating floor on the ground level outside the pedestal of Unit-1

The grating floor on the ground level outside the pedestal of Unit-1 was investigated from April 10 to 18, 2015. A running robot machine was sent through the PCV penetration X-100B. The robot patrolled clock-wise and anti-clock-wise by about 180 degrees for investigating damaged conditions of existing structures and presence of obstacles. Figure 2-9 and Figure 2-10 present a part of the photos taken during the anti-clock-wise and clock-wise patrols, respectively. As seen in Figure 2-9, no big damage was recognized on the HVH (heating ventilating handling unit), PLR piping, pedestal walls, PCV inner walls, etc., although fallen objects were noticed on the patrol path.

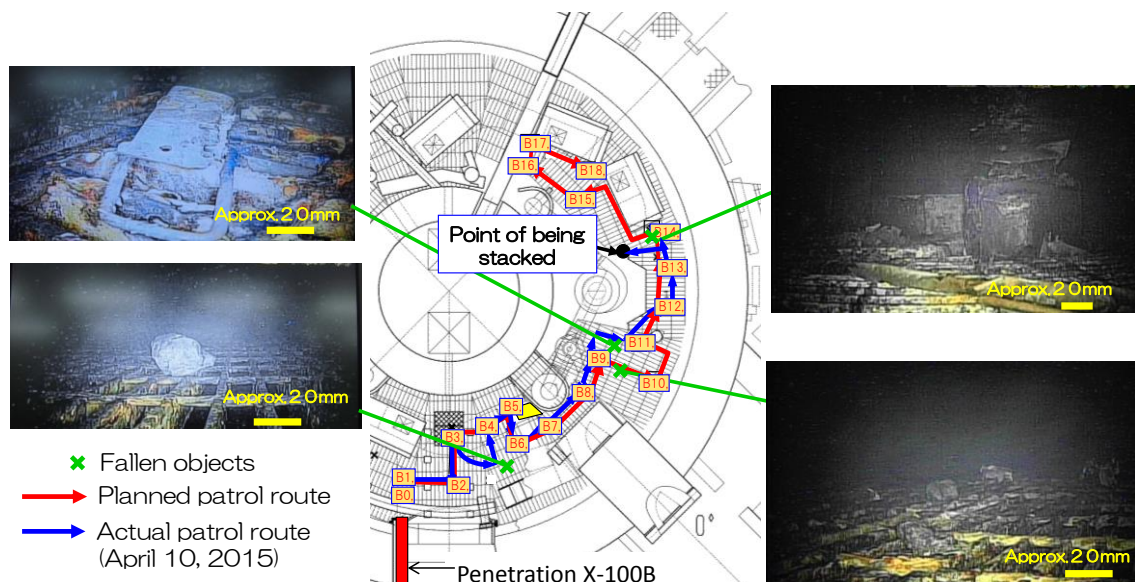

Figure 2-9 Photos taken during the anti-clock-wise patrol [9]

[9] Handout document 3: Action progress towards decommissioning of Units 1 to 4 of Fukushima Daiichi Nuclear Power Station, 17th Decommissioning and Contaminated Water Response Team Joint Meeting, April 30, 2015

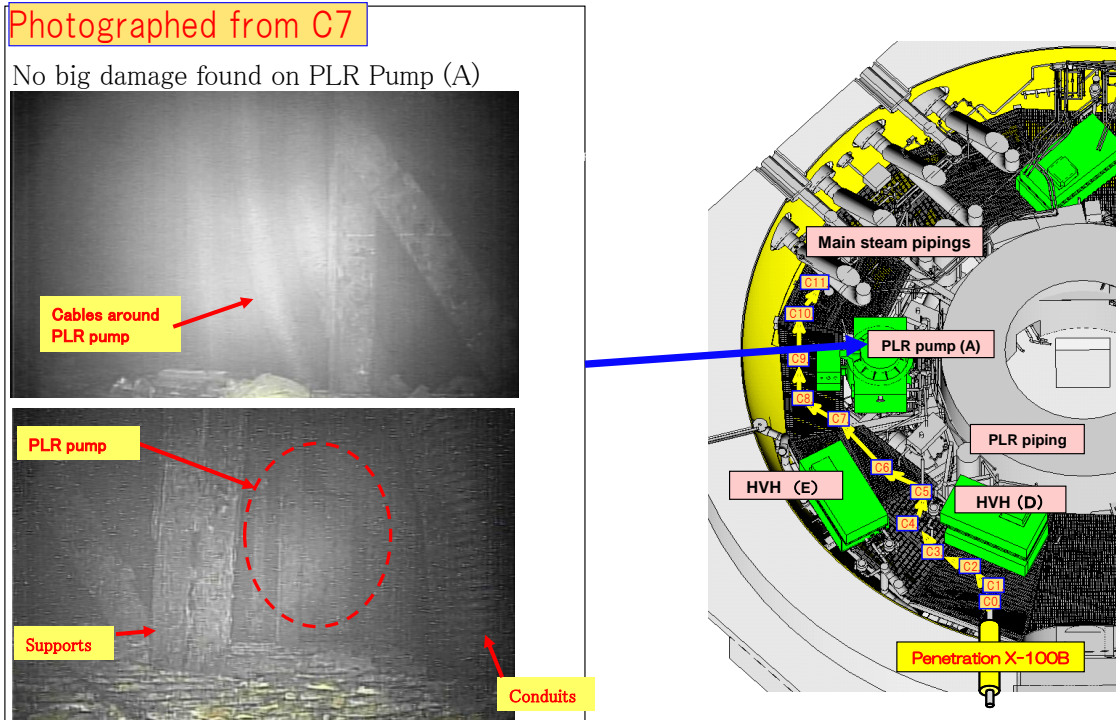

Figure 2-10 Photos taken during the clock-wise patrol [9]

(7) Investigation of Unit-1 using the muon tomography measurement device

A fluoroscope technology for nuclear reactors (transmission method) using muons is being developed jointly by the International Research Institute for Nuclear Decommissioning (IRID) and the High Energy Accelerator Research Organization (KEK) of Japan, as a project within the “Development of detecting technologies of fuel debris in a nuclear reactor” under the “Project of Decommissioning and Contaminated Water Management in the FY2013 Supplementary Budget” sponsored by the Agency for Natural Resources and Energy (ANRE). Figure 2-11 [10] shows the points of measurement on the Unit-1 reactor building Floor 1. At Point 1 and Point 2 the data were collected for 96 days from February 9 to May 21, 2015, and at Point 3 the data were collected for 106 days from May 25 to September 7, 2015. The conditions in the reactor were evaluated from the collected data.

Figure 2-12 shows the image of the reactor predicted from the design (left) and the image of the actual reactor obtained by muon measurements for 96 days (right), both at Point 1. The basic principle of measurements by the muon transmission method is the same with that of

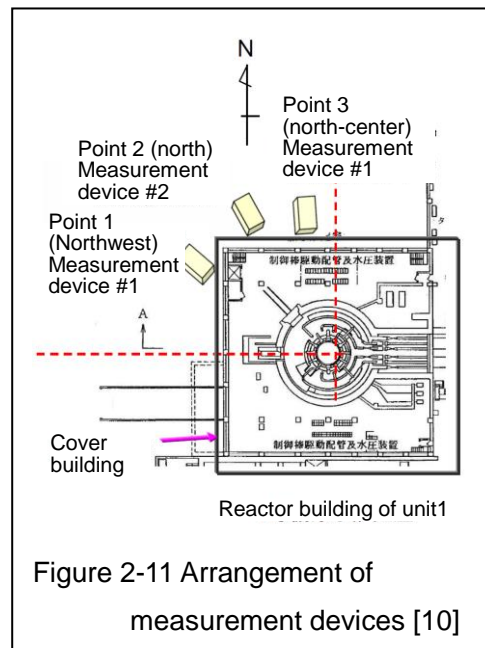

Figure 2-11 Arrangement of measurement devices [10]

[10] Final Report on Development of Fuel Debris Detection Technology under the government subsidized project “Decommissioning and Contaminated Water,” December 2015.

X-ray (Roentgen) photography. High density objects absorb more muons and are photographed in black. In the image of the reactor as designed with intact fuel, a black portion is recognized corresponding to the position of the core. In the image of the actual reactor, on the other hand, some recognizable equipment such as the spent fuel pool and isolation condensers are found, but there is no high density object (fuel) at the core position.

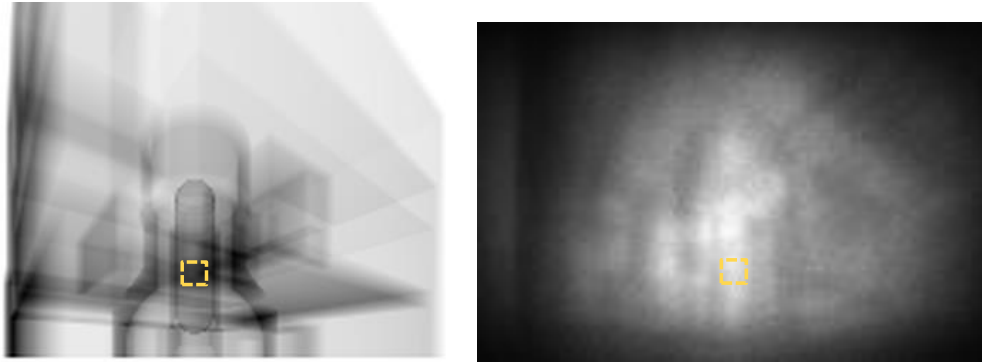

Figure 2-12 Muon image of the reactor predicted from the design (left) and that of the actual reactor based on measurements for 96 days (right) [11]  
(dotted region corresponds to the original core position)

By combining data measured using three muon measurement devices, images can be restructured in three dimensions. Distribution maps of high density materials are shown in Figure 2-13 at different elevations of the reactor building (R/B). The red region on the distribution maps is where high density materials are detected by the two muon measurement devices at each elevation. High density materials are recognized at the spent fuel pool position, but not at the core position.

---

[11] Handout document: Action progress towards decommissioning of Units 1 to 4 of Fukushima Daiichi Nuclear Power Station, 18th Decommissioning and Contaminated Water Response Team Joint Meeting, May 28, 2015

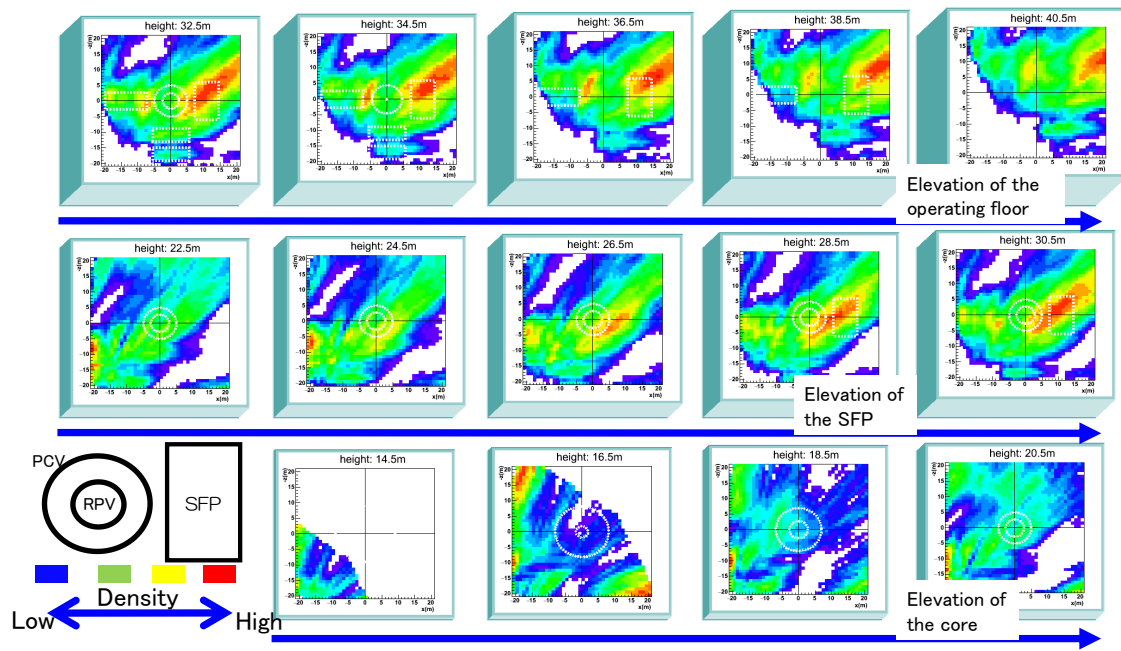

Figure 2-13 High density material distribution maps at three separate elevations

From these considerations, no fuel is thought to be left at the core position. This is consistent with the estimated conditions of the core and PCV previously announced by TEPCO.

(8) Investigation of the TIP room of Unit-1

The TIP (traversing in-core probe) room on the R/B ground floor was investigated from September 24 to October 2, 2015. This investigation was implemented to check feasibility of reducing the radiation dose near the PCV penetration X-6, stopping the water in the lower part of the PCV, repairing the PCV, etc.

Figure 2-14 presents the spatial air dose rates measured in the TIP room and Figure 2-15 shows a  $\gamma$ -camera photo taken there. A high radiation dose of above 100 mSv/h was observed near the PCV penetrations, especially around X-31, -32 and -33, while on the turbine side behind the chamber shield the dose rate was as low as below 2 mSv/h. The  $\gamma$ -camera photos located a radiation source near the penetrations X-31, -32 and -33 (Region 1 in Figure 2-15). No other outstanding radiation source was found in the room, including at the penetrations X-35A to -35D which were outside the view of the wide-angle lens camera (the area encircled by the broken line in Figure 2-15).

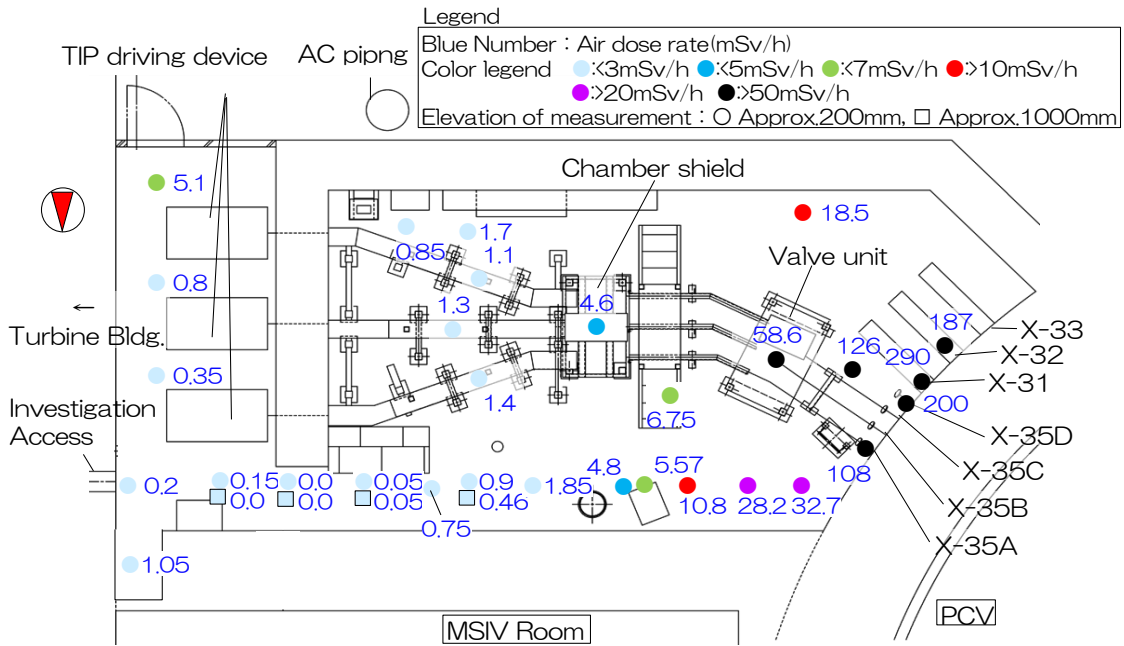

Figure 2-14 Air dose rates distribution measured in the TIP room [12]

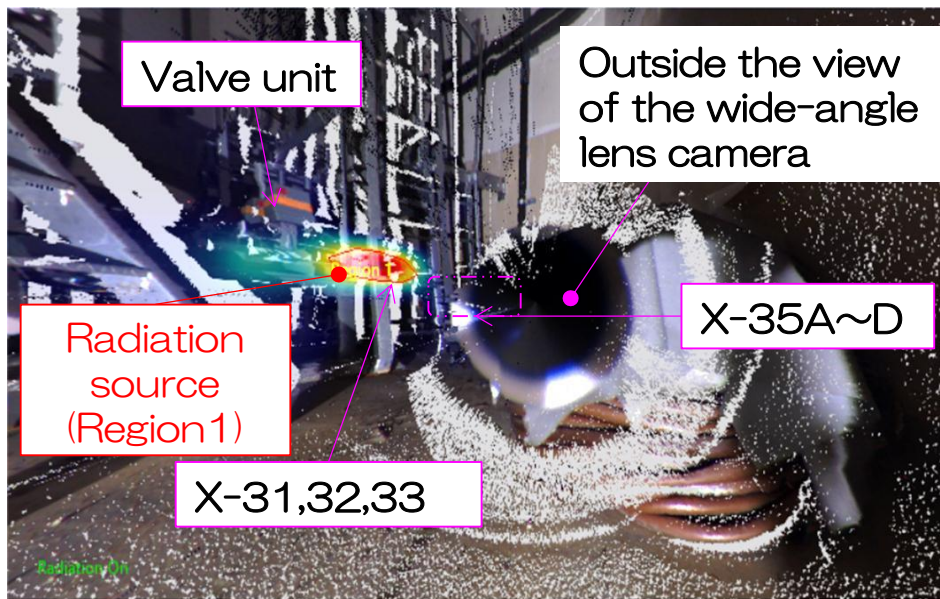

Figure 2-15  $\gamma$ -camera photo taken in the TIP room [12]

Exterior appearances of PCV penetrations, piping and other objects in the TIP room were surveyed by an optical camera. Some brown-colored specks hinting at flow lines were noticed around PCV penetration X-35A (Figure 2-16). But, as mentioned above, no radiation source was noticed around the area of penetrations X-35A to X-35D. No other marks hinting at leaks were recognized at any places around the penetrations, piping and other objects in the TIP room including the penetrations X-31, -32 and -33.

[12] Handout document 3: Action progress towards decommissioning of Units 1 to 4 of Fukushima Daiichi Nuclear Power Station, 23rd Decommissioning and Contaminated Water Response Team Joint Meeting, October 29, 2015  
Attachment 4-16





Figure 2-16 Optical camera photo taken at the penetration X-35 [12]

(9) Investigation inside the PCV (basement floor outside pedestal) of Unit-1 [UPDATE]

An investigation was conducted in March 2017 using a self-propelled investigation device to find the spreading area of fuel debris of the basement floor outside the pedestal and whether the debris had reached the PCV shell. Figure 2-17 shows the survey area and survey schematics. The self-propelled investigation device was operated on the Floor 1 grating floor, and video cameras and dosimeters were lowered to observe the PCV bottom and outside the pedestal at the survey points shown in Figure 2-18.

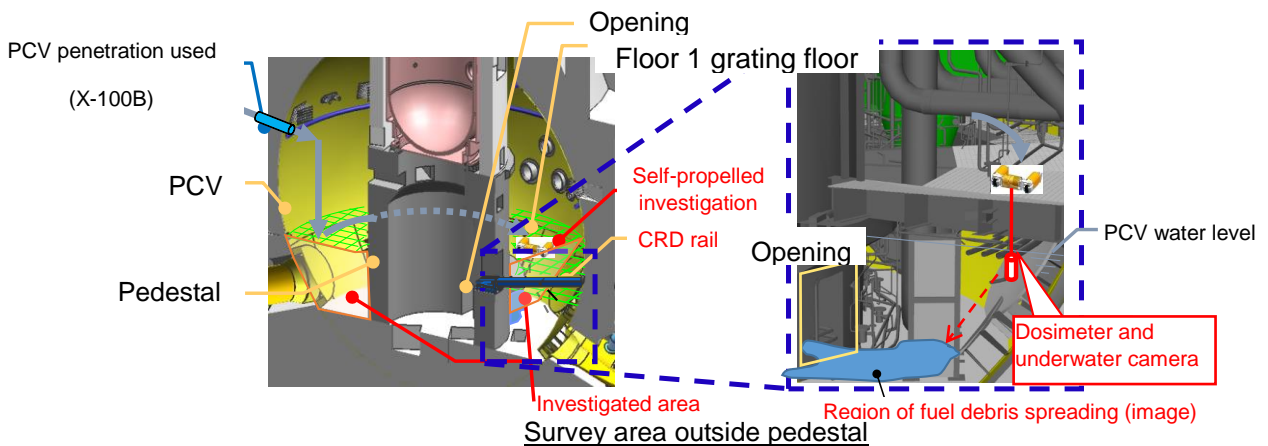

Figure 2-17 Survey area and survey schematics [13]

[13] Hand-out document: Investigation Plan of Inside Reactor Containment Vessel, 53rd Session of the Committee on Supervision and Evaluation of the Specific Nuclear Facility, May 22, 2017

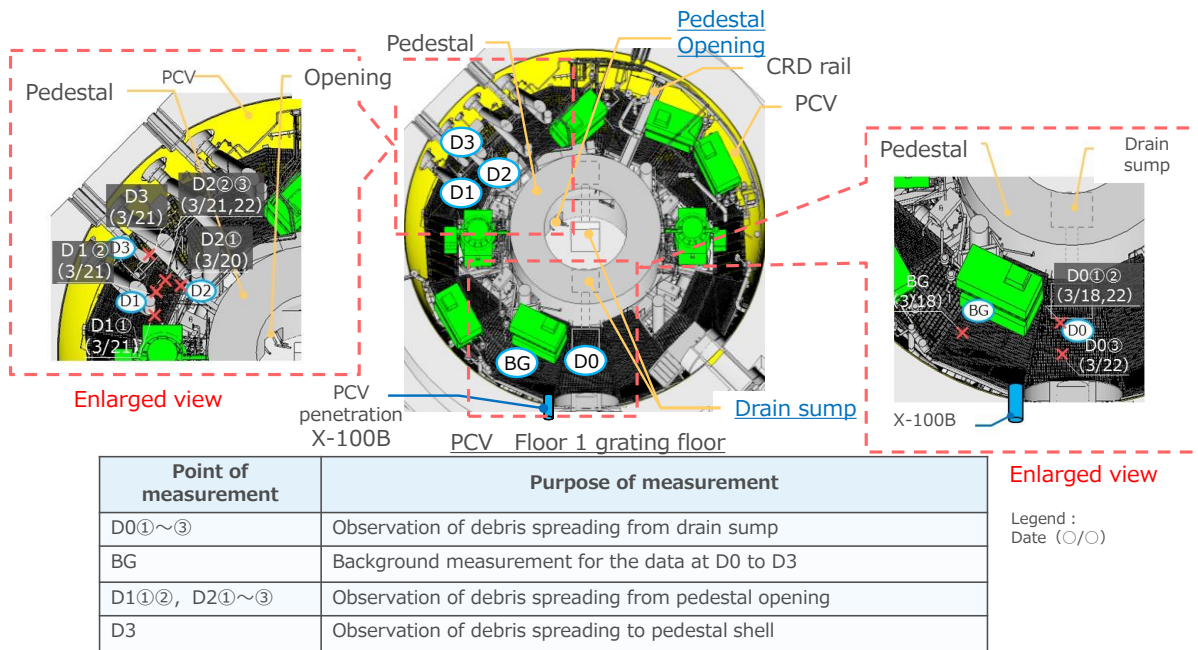

Figure 2-18 Survey positions [14]

Figure 2-19 presents the observation results by cameras from Point D0 near the drain sump outside the pedestal. No big damage or collapse of structures around the drain sump can be confirmed.

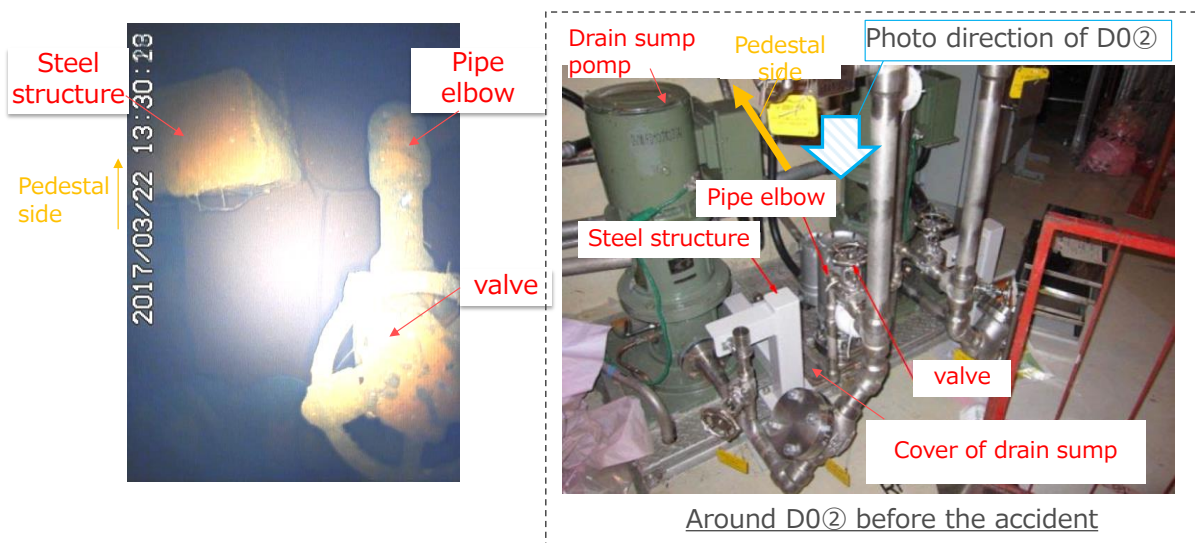
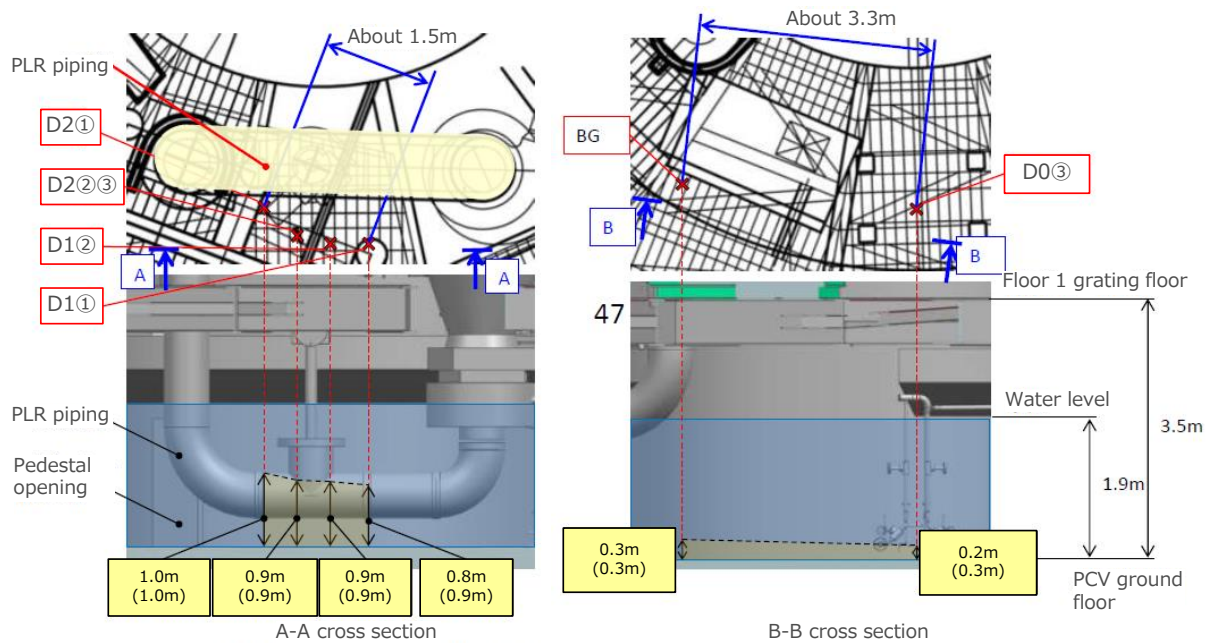

Figure 2-19 Observation from Point D0 [14]

(Left: Camera photo from Point D0, Right: View around Point D0 before March 11, 2011)

The sediment height at the PCV bottom was estimated (Figure 2-20) using the distance that the sensor was lowered from the self-propelled investigation device, and the distance between the sensor and sediment obtained by analyzing the photo image. It was about 0.8 to 1.0 m at Points

D1 and D2 near the pedestal opening, and 0.2 to 0.3 m at Points BG and D0 away from the pedestal opening. The sediment height was confirmed to be higher closer to the pedestal opening than at a distance from the pedestal opening.



Height calculated from sensor position

- ※1: Sediment heights estimated from the distance between the sensor and sediment using the structure from motion (SFM) technique and the distance the sensor was lowered
- Numbers in the yellow frames are the sediment heights estimated from photo image analysis
- Numbers in parentheses are the lowest elevation of the sensor
- Sediment thicknesses below the surface are not confirmed

Figure 2-20 Estimated sediment heights [14]

Dose measurements focused on the relationship between the distance from the sediment surface and its dependence on the dose rate attenuation to investigate the presence of fuel debris under the sediment. The results are seen in Figure 2-21. The blue points in Figure 2-21 (left), representing dose rate measurements at Point BG, confirmed the good agreement with the results of analysis (red line) of a situation when Cs-137 had existed in the sediment surface layer and no fuel debris was in underlayers. It was estimated, therefore, that no or very little fuel debris was present in the sediment underlayers. The same thing was also confirmed at Point D0③.

Figure 2-21 (right) compares, on the other hand, the dose rate measurements at Point D2③, and the results of analysis of a situation when 0.9 m, 0.3 m or 0.1 m thick sediments were assumed to cover the fuel debris. A big difference was evident in the dose rate attenuation behavior between the cases of 0.1 m or 0.3 m thick sediments, but the difference was very minor in the cases of 0.3 m or 0.9 m thick sediments. After all, it could not be confirmed whether fuel debris was present underneath the sediments. This was the case, too, at Points D1 and D2.

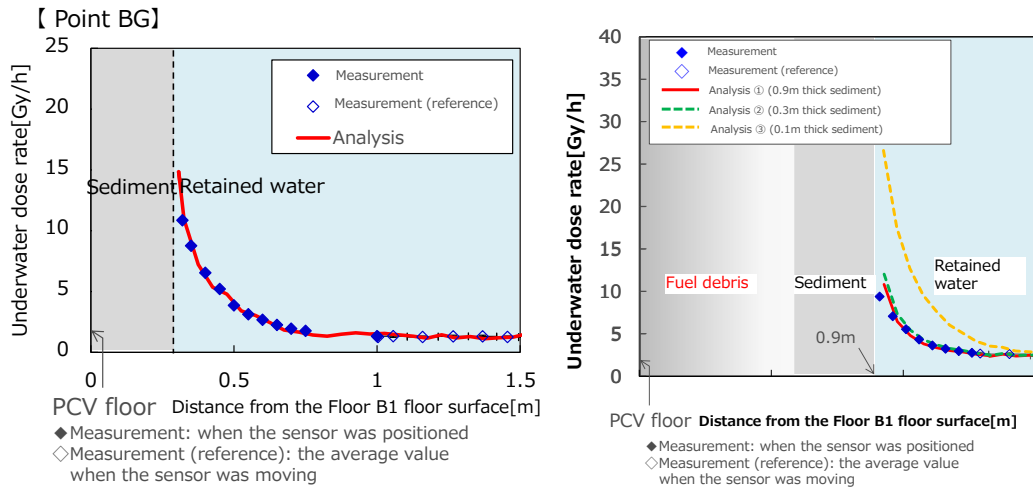

The sediment at the PCV bottom was sampled (Figure 2-22). The  $\gamma$ -ray emitting nuclides were analyzed, and the results are given in Table 2-1. The simplified fluorescent X-ray analysis identified, in the sediment, Fe and Ni in stainless steel used in core structures, thermal insulators or other parts, Zn contained in painting materials, and Pb contained in shielding materials.

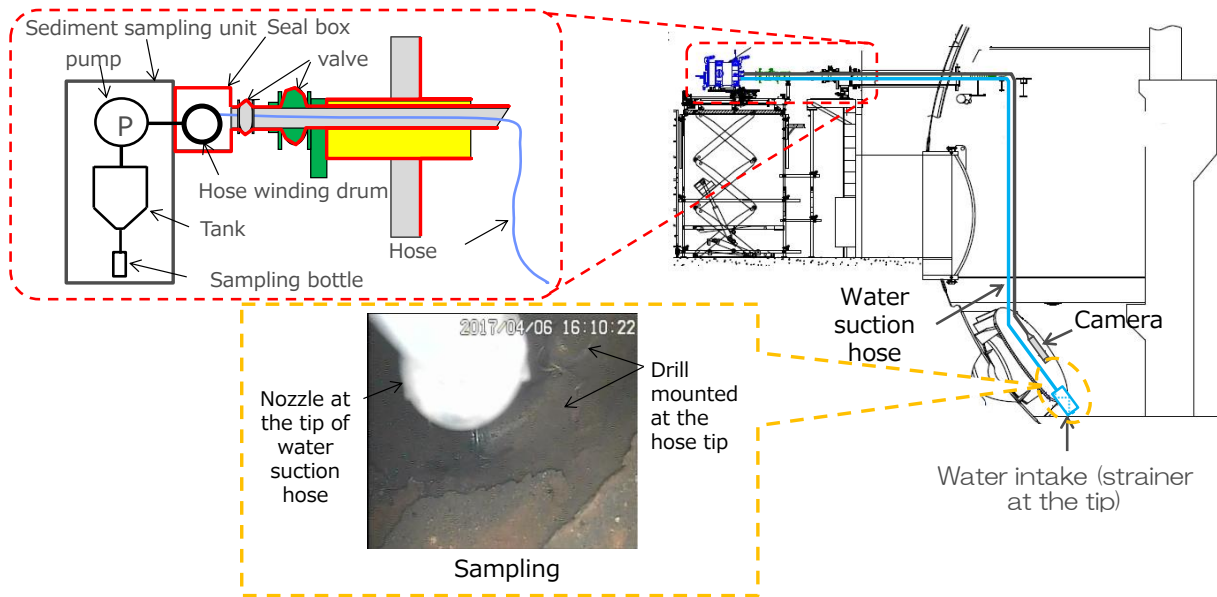

[15] Handout document 3: Action progress towards decommissioning of Units 1 to 4 of Fukushima Daiichi Nuclear Power Station, 42nd Decommissioning and Contaminated Water Response Team Joint Meeting, May 25, 2017

Table 2-1  $\gamma$  -ray emitting nuclides analysis [15]

Gamma emitting nuclides detected	Radioactivity [Bq/g]
Cs-134	3.5E+06
Cs-137	2.7E+07
Co-60	1.1E+07
Sb-125	7.0E+05

(10) Operating floor survey of Unit-3 reactor building [UPDATE]

The north side of the Unit-1 operating floor has been surveyed since November 2016. One of the survey items is the reactor well plug. The well plug was a three-layered structure of upper, middle and bottom layers and each layer was composed of three concrete slabs.

Figure 2-23 shows the well-plug damage conditions observed on the operating floor. The position of each well plug is estimated to have moved, as shown in Figure 2-24. The north piece of the upper well-plug was found to have moved to the west by about 720 mm. The center and north pieces of the upper well-plug were found to have been deformed downward by a maximum of 155 mm and 84 mm, respectively.

Figure 2-26 shows the results of dose measurement. Dose rates were found higher at the central part on the well-plugs and in the north side around the well-plugs.

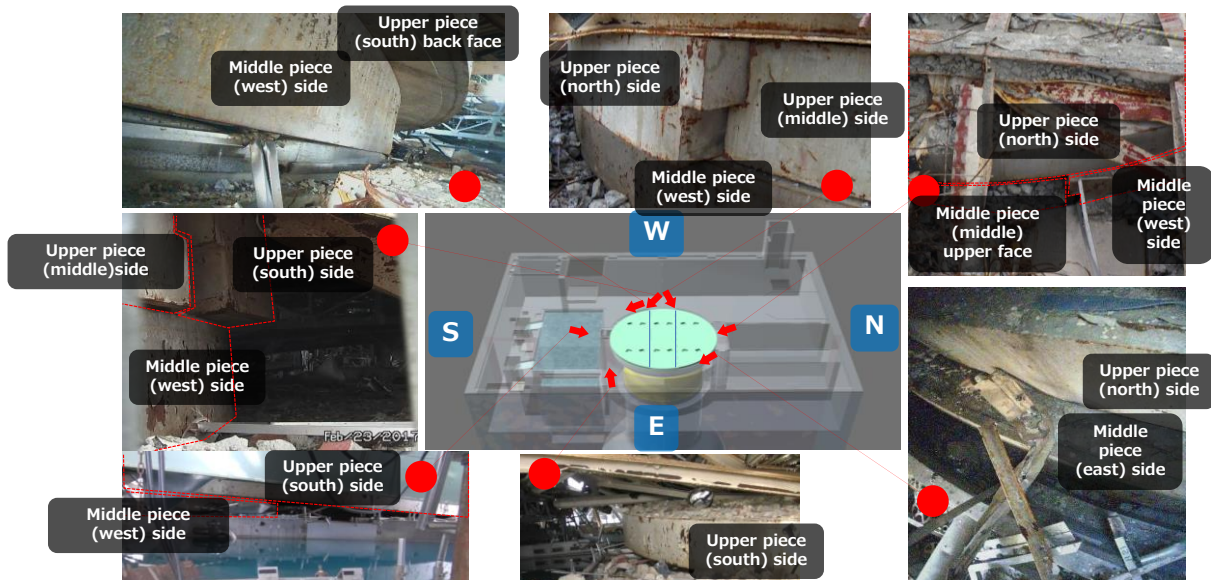
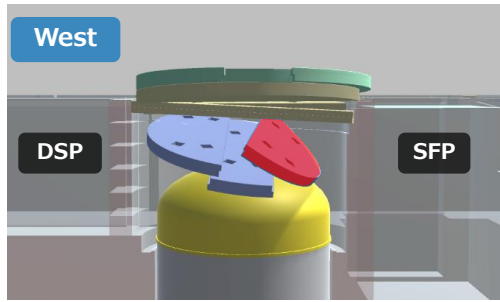

Figure 2-23 Well-plug pieces as they were on the operating floor [16]

[16] Handout document 3: Action progress towards decommissioning of Units 1 to 4 of Fukushima Daiichi Nuclear Power Station, 40th Decommissioning and Contaminated Water Response Team Joint Meeting, March 30, 2017



SFP: Spent Fuel Pool  
 DSP: Device Storage Pool

Figure 2-24 An image layout of well-plugs estimated from investigation [17]

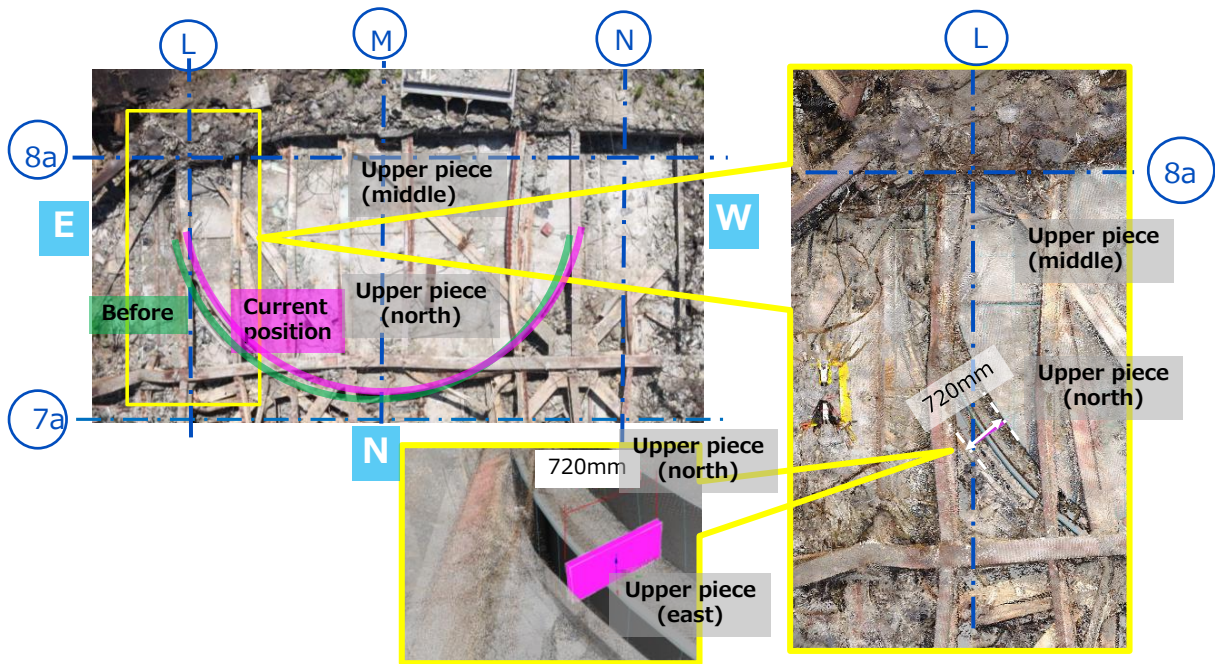

Figure 2-25 Well-plug pieces shifted from original positions [17]

[17] Handout document 3: Action progress towards decommissioning of Units 1 to 4 of Fukushima Daiichi Nuclear Power Station, 40th Decommissioning and Contaminated Water Response Team Joint Meeting, September 28, 2017

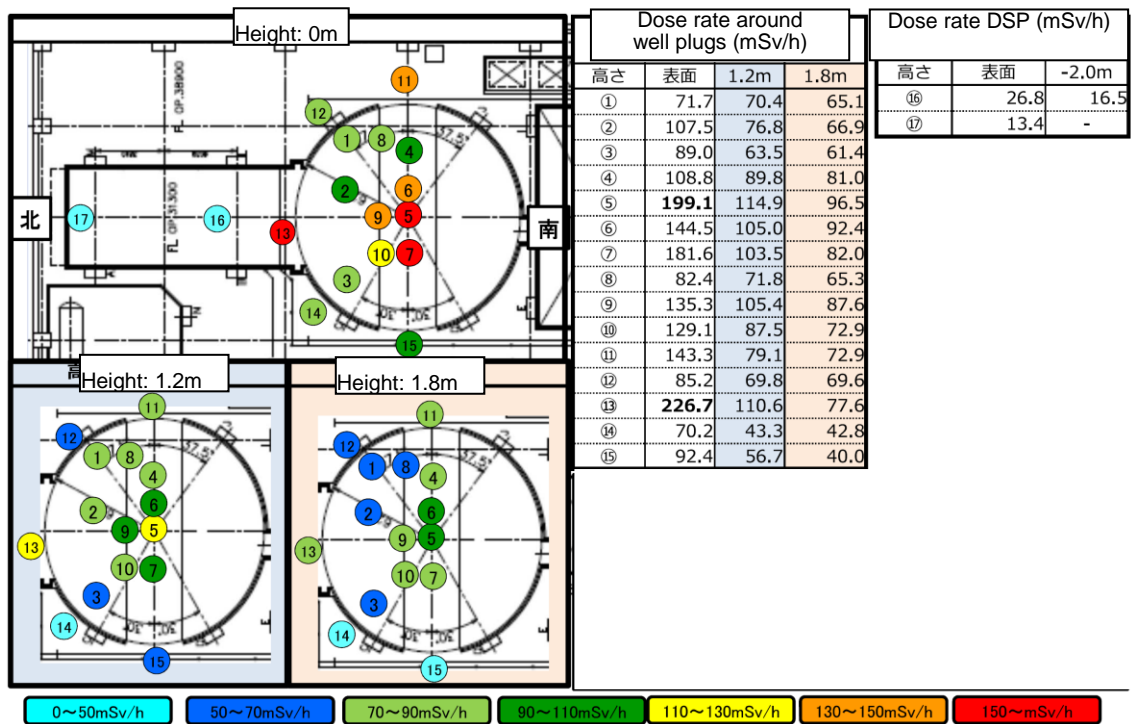

Figure 2-26 Dose rates on the operating floor [18]

[18] Handout document 3: Action progress towards decommissioning of Units 1 to 4 of Fukushima Daiichi Nuclear Power Station, 44th Decommissioning and Contaminated Water Response Team Joint Meeting, July 27, 2017

### 3. Conditions of Unit-2 core and the PCV

#### (1) In-containment water level measured

In March 2012, investigation was conducted into the PCV of Unit-2, when photos were taken by cameras, the level of water retained in the PCV was confirmed, and dose rates and temperatures were measured [19] by inserting survey devices into the PCV through a hole dug at the PCV penetration (X-53, on the first floor of the reactor building).

The level of water retained was confirmed to be about 60 cm above the D/W floor by the video image scope (as of March 26, 2012) (Figure 3-1).

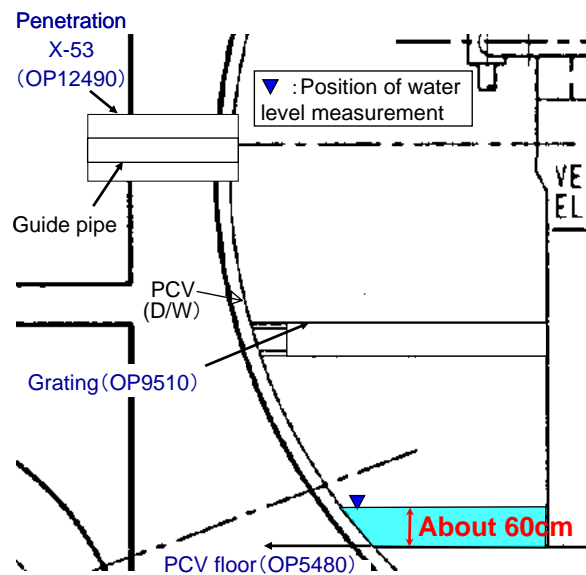

Figure 3-1 Measured level of retained water in Unit-2 PCV

#### (2) Survey results near the PCV pedestal opening of Unit-2

In July and August 2013, a survey was conducted inside the PCV of Unit-2, when instrumentation was introduced through the PCV piping penetration X-53 (reactor building first floor) to take camera images and make dose and temperature measurements in the vicinity of the control rod drive mechanism (CRD) replacement rail and pedestal opening (Figure 3-2) [20].

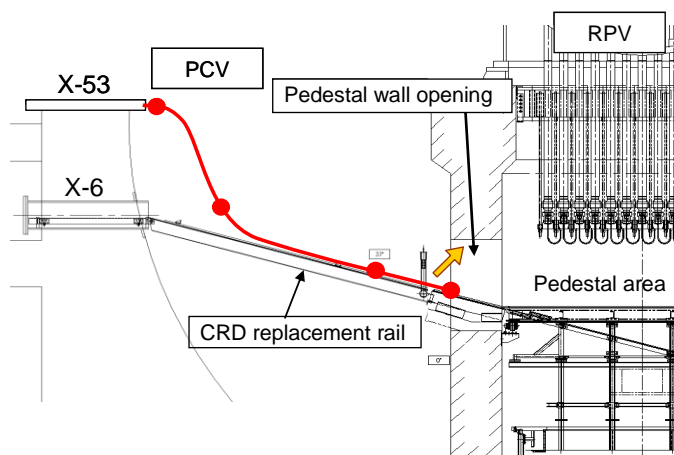

Figure 3-2 Survey areas inside Unit-2

Camera images were taken at the pedestal opening into its inside and after

photo processing for noise and contrast, they confirmed the position of the control rod position indicator probe (PIP) cables in the upper part of the pedestal opening, but no clear information was obtained regarding what was in the lower part inside the pedestal (Figure 3-3).

Dosimeters measured the dose rates as far as the top of the CRD replacement rails. The values were about 45 – 80 Sv/h. As supplementary information, dose rates were estimated from the camera image noises; they were about 30 Sv/h near the landing point in the replacement rail and

[19] "Results of PCV investigation and plan for identifying leak path", Technical workshop for Fukushima Daiichi accident, July 24, 2012

[20] Handout document, Progress in preparations for decommissioning of Units 1 to 4 of the Fukushima Daiichi Nuclear Power Station, 7th Decommissioning Measures Steering Panel, August 28, 2013



about 36 Sv/h near the pedestal opening. No clear indication was obtained about gaining access to fuel debris, even via the pedestal opening on the CRD replacement rail because access to fuel debris will result in rapid dose rate increase.

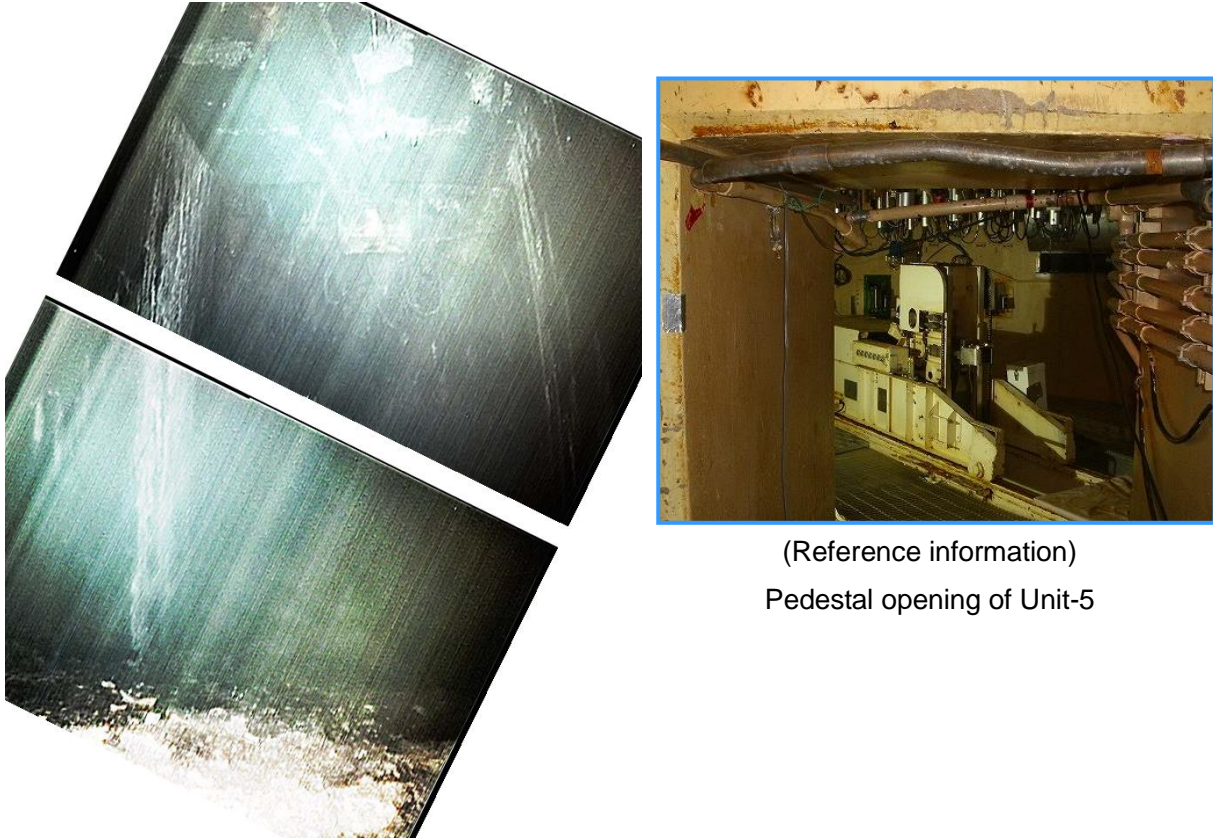

(Reference information)  
Pedestal opening of Unit-5

Figure 3-3 Photos taken inside the PCV pedestal at the pedestal opening (processed image)

(3) Test results of injecting nitrogen gas into the S/C of Unit-2

The S/C pressure was confirmed to be 3 kPag (as of May 14, 2013) in a nitrogen gas injecting test into the S/C done in May 2013. The absolute water level in the S/C was not accurately known, but it was confirmed to be approximately on the level of the nitrogen gas inlet (O.P. 3780), because some reasonable pressure due to the water head should exist at the inlet if the S/C were almost filled with water. If the low water level in the

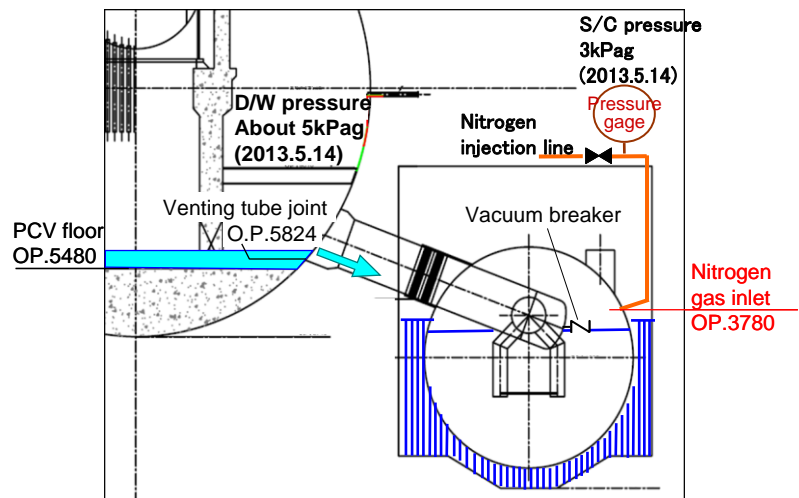

Figure 3-4 Closed space assumed in Unit-2 S/C

D/W is considered in combination, the water injected into the reactor vessel is considered to have reached the S/C via the D/W and venting tubes. If this hypothesis is correct, the current S/C water level will be on the same level as that of water retained in the torus room [21] (Figure 3-4).

Since December 2011, the hydrogen gas concentration and Kr-85 radioactivity measured by the containment gas control system of Unit-2 increased as a consequence of D/W pressure decreasing operations. This test was conducted to check if hydrogen and Kr-85 remained that had originated in the early phase of the accident as in the Unit-1 S/C.

The gradual pressure increase of the S/C from 3 kPag to 7 kPag before and after the injection confirmed that nitrogen gas had been injected into the S/C. But no change was observed in the hydrogen gas concentration and Kr-85 radioactivity measured by the PCV gas control system. Further tests were conducted to check if this was because there was no flow path from the S/C to the D/W or the hydrogen gas concentration in the S/C was already too low to send response signals.

In July 2013, upon injecting nitrogen gas into the D/W, a D/W pressure increase and an accordingly slight increase of S/C pressure were confirmed. Also, in October 2013, upon injecting nitrogen gas into the S/C, the S/C pressure increased to the level of the D/W pressure, after that, both pressures showed similar increasing trends in conjunction. When the nitrogen gas injection to S/C was terminated, the S/C pressure decreased concomitantly with the D/W pressure [22].

From these findings, it was confirmed that nitrogen gas injected into the S/C was flowing to the D/W. And also, from findings of nitrogen gas injection into the S/C flowing to the D/W with no change in hydrogen gas concentrations observed in the PCV gas control system, it was concluded that no more hydrogen gas remained in the S/C. It is considered, in this situation, that the vacuum breaker valve (OP. 3305) was not flooded and the nitrogen gas was flowing through this valve, because the water level in the reactor building was below about OP. 3400 during the tests and the S/C water level would follow the torus room water level (torus room water level minus level decrease due to internal pressure)

#### (4) Investigation of the torus room of Unit-2

In the Unit-2 torus room investigation in April 2012, a robot accessed the gallery inside. Videotaping, dose rates measurement, acoustic checks, etc. were carried out to the extent possible [23].

No water leaking position in the S/C has been located yet. At least, no leak was confirmed on the flange, etc. of the S/C manholes, as far as the camera photos show (Figure 3-5).

---

[21] Handout document, Progress in preparations for decommissioning of Units 1 to 4 of the Fukushima Daiichi Nuclear Power Station, 3rd Decommissioning Measures Steering Panel, May 30, 2013

[22] Handout document, Action progress towards decommissioning of Units 1 to 4 of Fukushima Daiichi Nuclear Power Station, 1st Steering Committee towards Decommissioning, December 26, 2013

[23] Handout document, 5th Steering Committee, Government – TEPCO Joint Board on Mid- and Long-term Response Policy, April 23, 2012

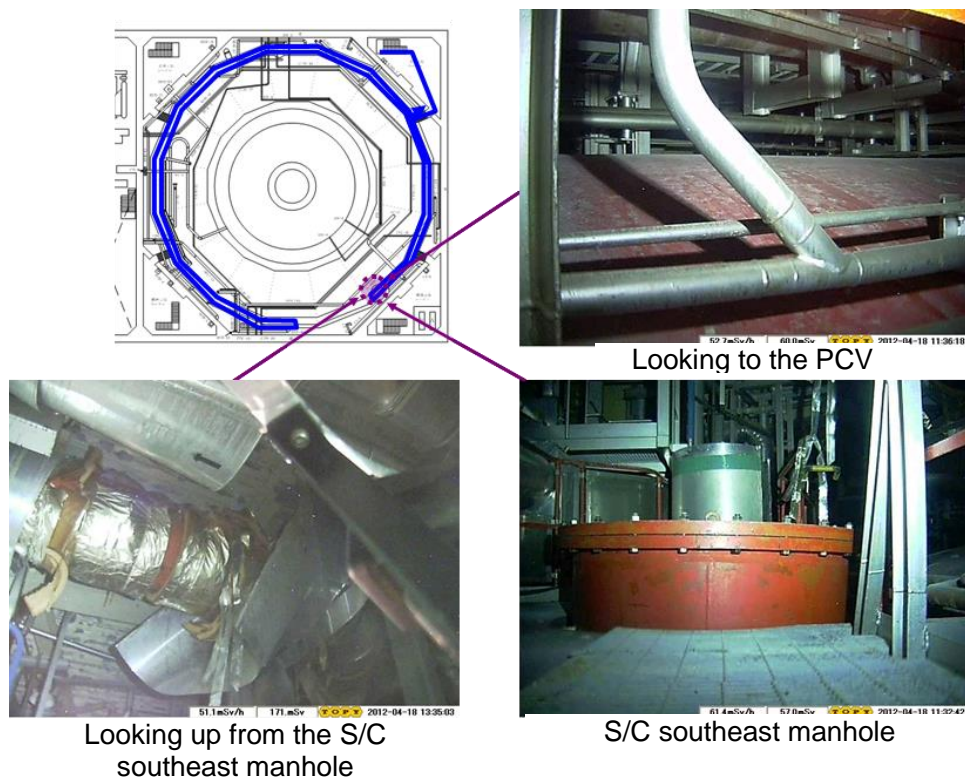

Figure 3-5 Camera photos in the torus room of Unit-2 (part)

(5) Investigation of the situation at the bottom of the vent tubes in the torus room of Unit-2

In the Unit-2 torus room, further investigations were made in December 2012 and March 2013, and the area around the lower end of venting tubes was surveyed by a robot. A small patrol vehicle, which was mounted on the tip of an arm of a four-leg robot, was set on the S/C, from which it accessed the lower end of the venting tube and took photos [24].

No water leaking position in the S/C has been located yet. At least, no leak was confirmed from the lower end of venting tubes within the visible range (Figure 3-6).

[24] Handout document, Progress in preparations for decommissioning of Units 1 to 4 of the Fukushima Daiichi Nuclear Power Station, 1st Decommissioning Measures Steering Panel, March 28, 2013

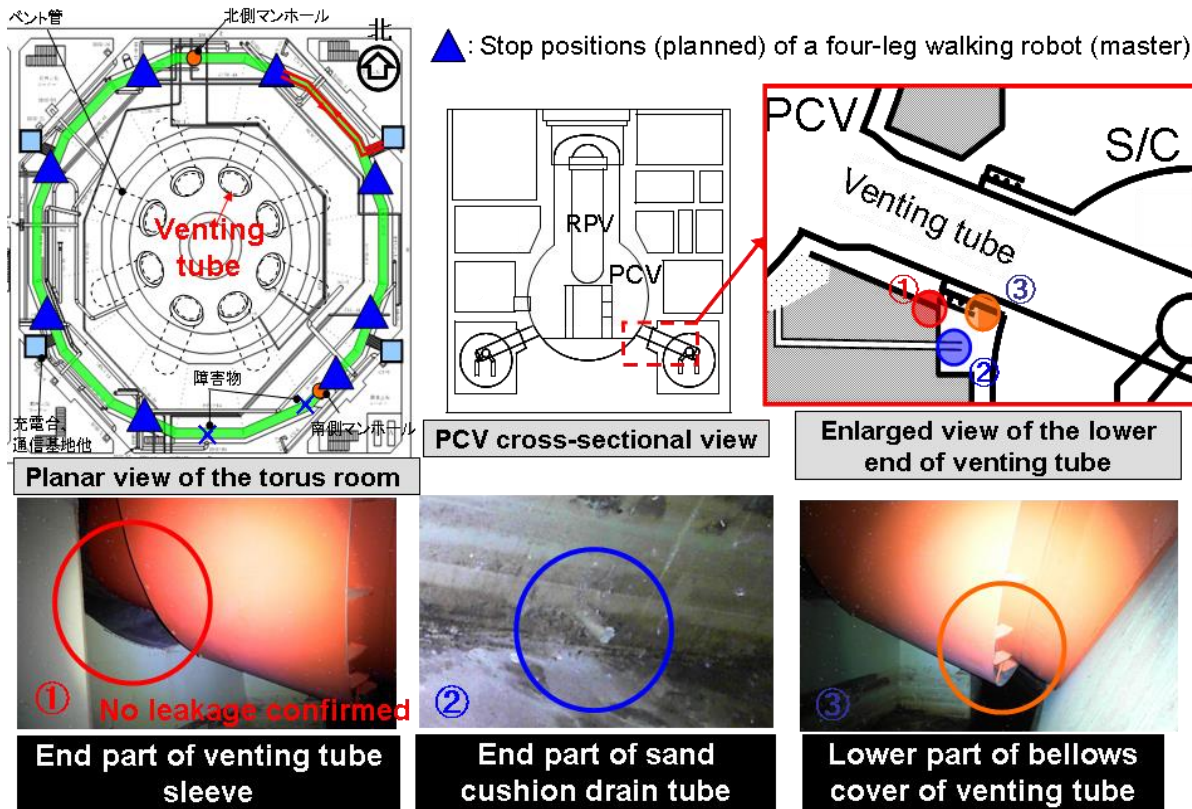

Figure 3-6 Camera photos around the lower end of the venting tubes in the torus room of Unit-2 (part)

(6) S/C water level measurements of Unit-2

In January 2014, the S/C water level was remotely measured using ultrasonic techniques from the chamber outer surface. That is, the ultrasonic waves reflected by the S/C internal structures (as well as the opposite wall) were continuously measured. The water level could be estimated by observing where the reflective waves disappeared (Figure 3-7) [25].

The S/C water level is in correspondence with the level of water retained in the torus room. This is consistent with the water level estimated earlier by the nitrogen gas injection tests. This information confirms that water leaks occurred at the S/C lower position (including piping).

[25] Handout document: Action progress towards decommissioning of Units 1 to 4 of Fukushima Daiichi Nuclear Power Station, 2nd Decommissioning and Contaminated Water Response Team Joint Meeting, January 30, 2014.

Measurement date	Jan. 14, 2014	Jan.15, 2014	Jan. 16, 2014
<b>S/C water level</b>	<b>About OP. 3210</b>	<b>About OP. 3160</b>	<b>About OP. 3150</b>
<b>Water level retained in the torus room (reference info.)</b>	<b>About OP. 3230</b>	<b>About OP. 3190</b>	<b>About OP. 3160</b>
<b>Level difference</b>	<b>About 20mm</b>	<b>About 30mm</b>	<b>About 10mm</b>
<b>Method of measurement</b>	<b>Direct distance measurement between underwater structures</b>		

(Note) S/C water level seems to be affected by water level retained in the torus room

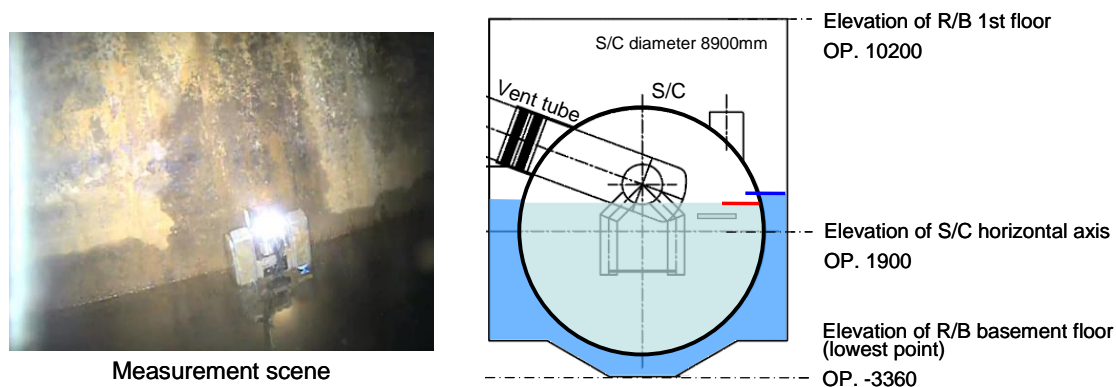
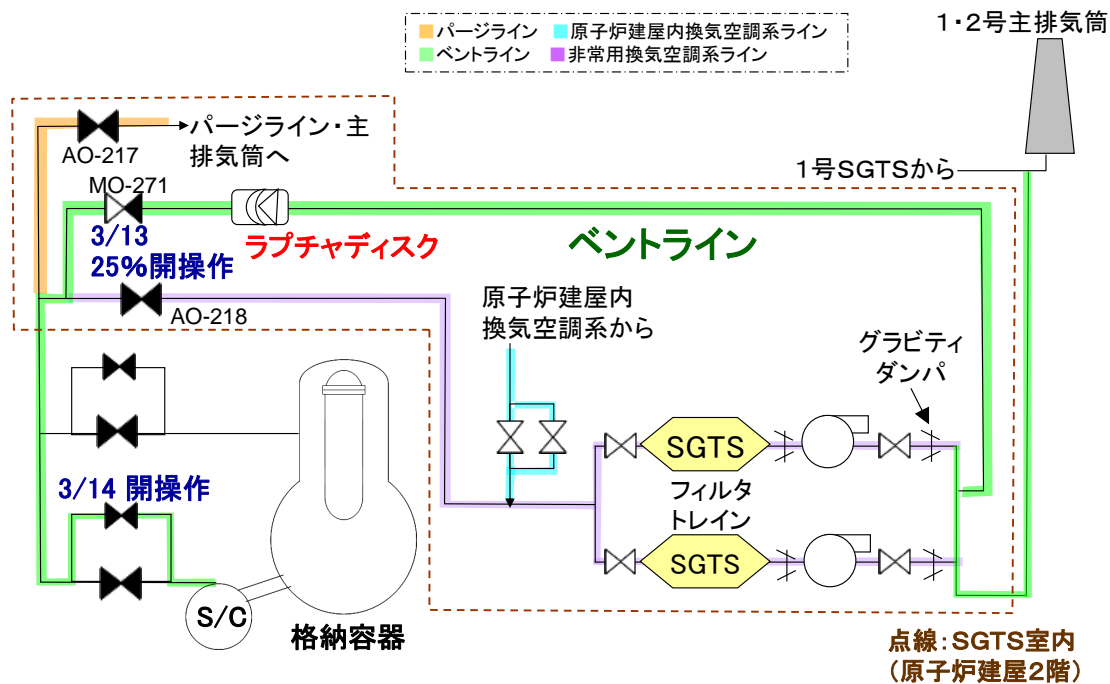

Figure 3-7 S/C water level measurements of Unit-2

(7) Investigations relevant to the rupture disk in the Unit-2 SGTS room

Radiation levels were measured in November 2014, around the rupture disk and the standby gas treatment system (SGTS) filters mounted in the Unit-2 SGTS room as a step to solve the Unit-2/Issue 9 “Rupture disk actuated at Unit-2.”

Figure 3-8 illustrates the system configuration for venting from the primary containment vessel (PCV) to the Unit-1 and -2 stack. The green line is the venting line to release the PCV pressure when it exceeds its design pressure. This venting line bypasses the SGTS filters mounted, as early as the very beginning of the construction phase, on the emergency heating and ventilation air conditioning system. This venting line is also connected to the purge line as well as the reactor building heating and ventilation air conditioning (R/B HVAC) system line. Valves in the figure are shown in black when fully closed, or when the opening aperture is unknown, and white when fully opened. The opening aperture of the valve (MO-271) located immediately upstream from the rupture disk was recorded as being operated to 25% mid-open position as of March 13, 2011. The valve continues to hold the state even now. On the other hand, the valve immediately downstream on the S/C side of the PCV was operated to open its large and small vent valves until March 14, 2011, but their real states when the venting line pressure reached the rupture disk working pressure remain unknown.



パーズライン	Purge line
原子炉建屋内換気空調系ライン	R/B HVAC line
ベントライン	Venting line
非常用換気空調系ライン	Emergency HVAC line
1・2号排気等	Unit-1 & -2 stack
1号SGTSから	From Unit-1 SGTS
3/13 25% 開操作	25% opening operation on March 13
ラブチャディスク	Rupture disc
フィルタートレイン	Filter train
グラビティダンパ	Gravity damper
格納容器	PCV
点線 : SGTS 室内 (原子炉建屋 2 階)	Dotted line: In SGTS room (R/B 2nd floor)

Figure 3-8 System configuration relevant to the rupture disk

Figure 3-9 shows the results of radiation measurement around the rupture disk. The measurement was done on October 8, 2014. The radiation level measured was 0.30 mSv/h from the north face, while it was 0.08 mSv/h from the south face. Both were at about the same level of 0.30 mSv/h (north face) and 0.12 mSv/h (south face) before the rupture disk on the venting line, or 0.30 mSv/h (north face) and 0.16 mSv/h (south face) after the disk. These values indicate that the area is not contaminated to the extent predictable for such lines as the Unit-1 venting line, through which gas containing a large amount of radioactive materials went.

Furthermore, there exists a consistent tendency in the surrounding area that the levels on the north face are higher than those on the south face. This may indicate that the observed radiation levels were influenced by some unknown high level radioactive source existing on the north side of

the rupture disk area, i.e., the radiation levels observed on the north face of the venting line and the rupture disk were actually measurements of radiation coming from that unknown high level radioactive source on the north side without the shielding effect of the piping, while the radiation levels obtained on the south face were actually measured after being shielded by the piping. Therefore, it is highly likely that the rupture disk and the piping around the disk are the least contaminated.

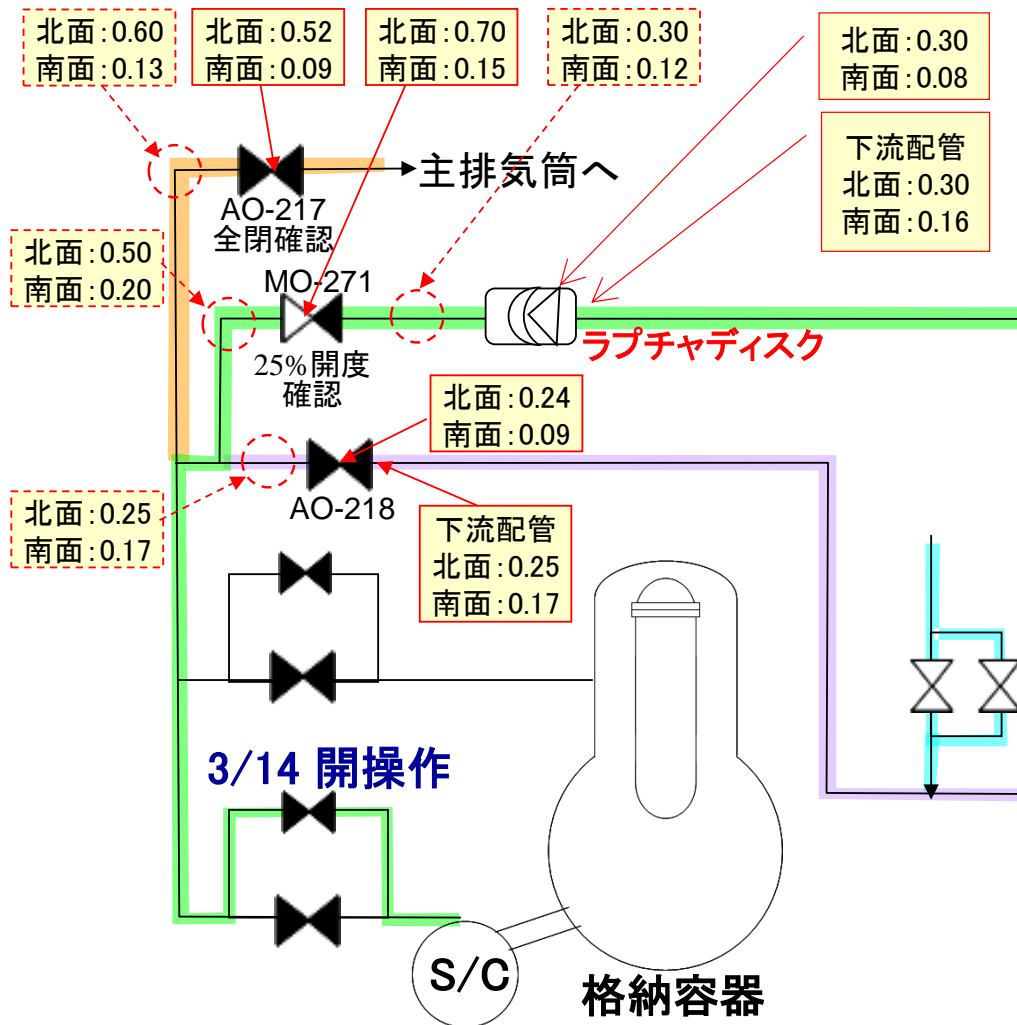

北面	North face
南面	South face
主排気筒	Stack
全閉確認	Full-closure confirmed
25%開度確認	25% aperture confirmed
下流配管	Line after (the rupture disk)
開操作	Opening operation
格納容器	PCV

Figure 3-9 Radiation levels observed around the rupture disk (mSv/h)

As described above, the unknown high level radioactive source on the north side of the rupture disk area was assumed to be fairly strong. For this reason, the radiation measurement on the north side was conducted using a robot (November 12, 2014).

Figures 3-10 and 3-11 show the radiation measurement results around the SGTS filters (A) and (B), respectively. For both filters (A) and (B), radiation levels as high as about 1Sv/h were obtained. The maximum contamination has been observed on the HEPA filter at the SGTS filter outlet. Generally, the SGTS filter captures radioactive materials from its inlet side, which means that the results observed may indicate the gas containing the radioactive materials flowed into the SGTS filter from the opposite direction (backward flow). As clearly recognizable from Figure 3-8, there are two possible paths for this backward flow: from the Unit-2 venting line and the Unit-1 venting line (this is the same situation as having occurred when hydrogen gas flowed backward from Unit-3 to Unit-4).

Contamination around the rupture disk was not confirmed by the radiation measurements in the relevant area in October 2014. But still the information is insufficient in order to judge whether the Unit-2 rupture disk worked at the time of accident. Therefore, the investigation continues on this issue, including the identification of the source which contaminated the SGTS filters.



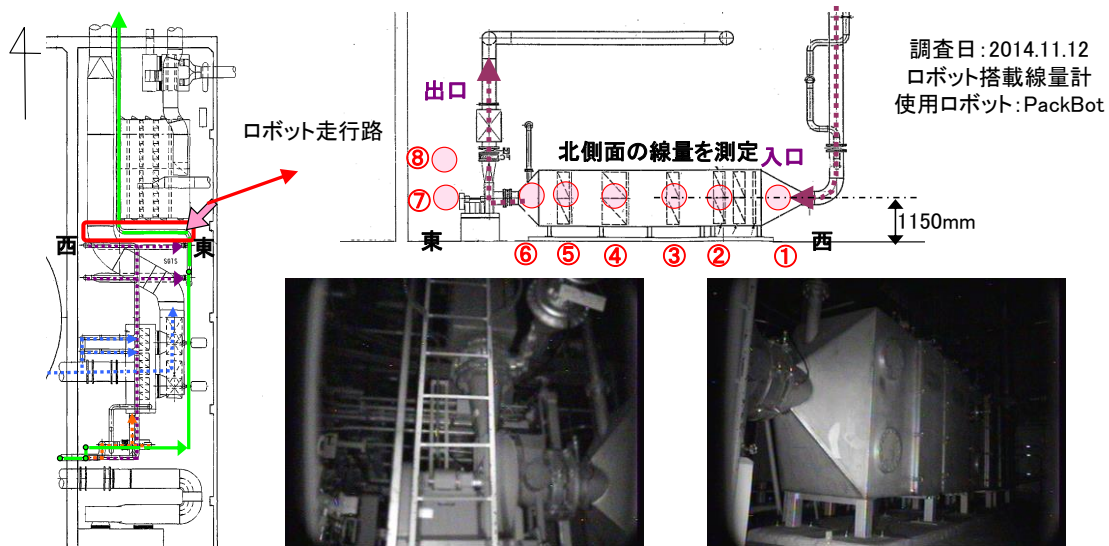

測定場所	⑧-A	⑦-A	⑥-A	⑤-A	④-A	③-A	②-A	①-A
測定高さ	2170mm	1150mm	1150mm	1150mm	1150mm	1150mm	1150mm	1150mm
線量率	79mSv/h	85mSv/h	400mSv/h	1Sv/h*	460mSv/h	220mSv/h	140mSv/h	69mSv/h

\*) フィルタトレイン表面から約20cm離れた位置(フィルタ中心面より約65cm)で測定した線量値

\*) Measured at the point about 20 cm from the filter train surface (about 65 cm from filter center)

ロボット走行路	Robot guide way
北側面の線量を測定	Dose measured on the north face
ロボット搭載線量計	Dosimeter mounted on a robot
使用ロボット	Robot used
測定場所	Point of measurement
測定高さ	Elevation of measurement
線量率	Dose rate
出口配管	Outlet pipe
出口部	Outlet
HEPA フィルター	HEPA filter
チャコールフィルター	Charcoal filter
プレフィルター	Prefilter
入口部	Inlet

Figure 3-10 Radiation level observed (SGTS filter (A))

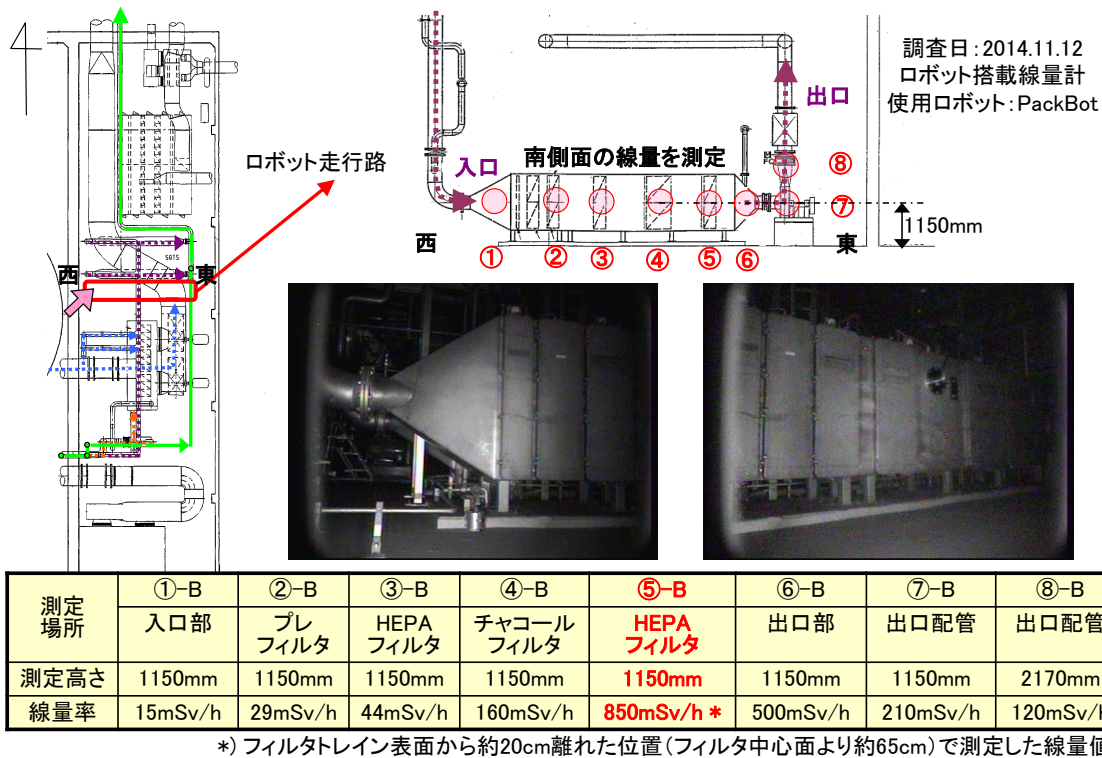

\*) Measured at the point about 20 cm from the filter train surface (about 65 cm from filter center)

南側面の線量を測定	Dose measured on the south face
-----------	---------------------------------

Figure 3-11 Radiation level observed (SGTS filter (B))

(8) Investigation of the area around PCV penetration X-6

In preparation for the internal investigation of the PCV and pedestal, shield blocks and iron plates were removed (between June 11 to October 1, 2015) from the front of PCV penetration X-6 (see Figure 3-12 Building layout), which had been selected as the access route. When the area around the penetration was investigated, during the removal work, some melted matter was found and a high radiation dose of more than 1,000 mSv/h was noticed on the penetration flange and on the floor.

Figure 3-13 shows a photo of the melted matter. The melt hung from the penetration flange and lay spread on the floor. It is thought to be materials that had covered cables of the CRD replacement machine or O-ring materials of the penetration flange seals. The melt on the floor was solidified and confirmed to be easily removable by spatulas or similar tools.

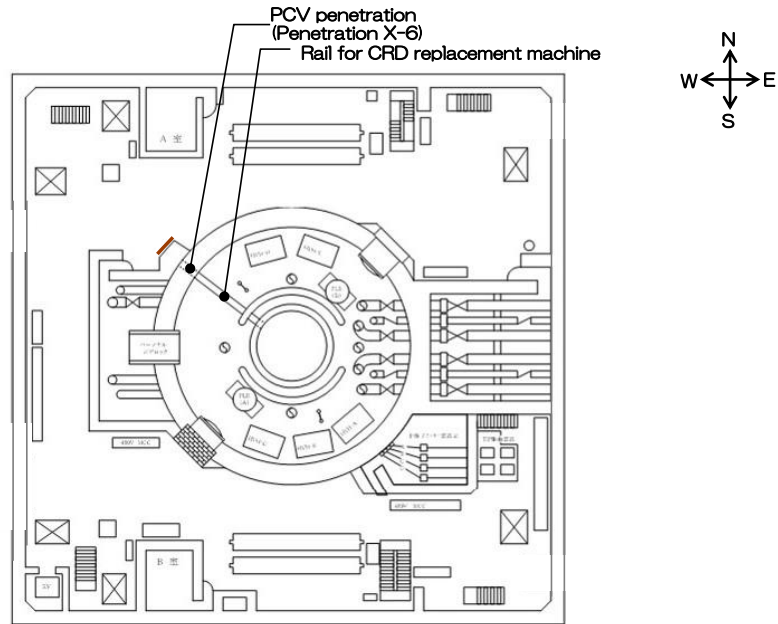

Figure 3-12 Layout on the ground floor of Unit-2 R/B [26]



Figure 3-13 Melted matter at the penetration flange [27]

[26] Handout document 3: Action progress towards decommissioning of Units 1 to 4 of Fukushima Daiichi Nuclear Power Station, 19th Decommissioning and Contaminated Water Response Team Joint Meeting, June 25, 2015

[27] Handout document 3: Action progress towards decommissioning of Units 1 to 4 of Fukushima Daiichi Nuclear Power Station, 21st Decommissioning and Contaminated Water Response Team Joint Meeting, August 27, 2015

Figure 3-14 gives the radiation dose rate measured on the surface. An increasing tendency for the surface dose is noticed in the order: “on the ceiling < in the middle < on the floor”; and especially a high dose rate is observed in the ditch after the shield blocks had been removed. The contamination might have spread from the area where the melt lay to the ditch. If the radiation dose difference between the locations of “at the penetration” and “on the wall” comes from the contribution of a radiation source inside the penetration X-6, it is estimated to be approximately 1 Sv/h at the maximum.

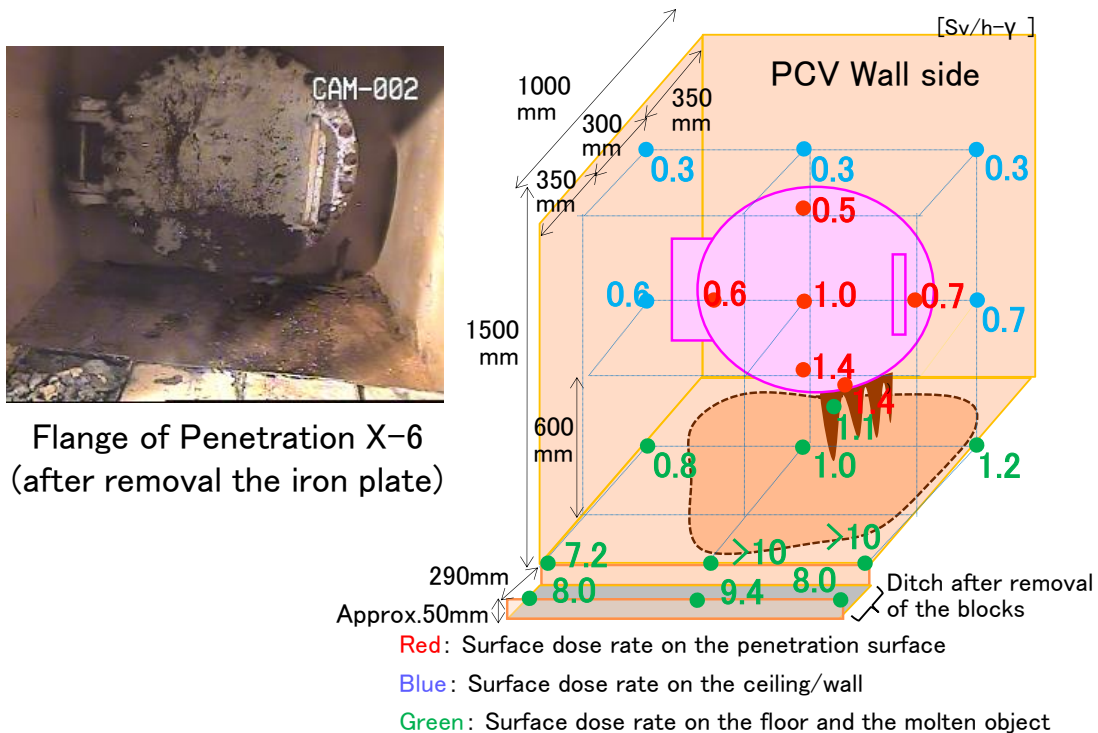

Figure 3-14 Measurement results of surface radiation dose rate [28]

(9) Investigation of Unit-2 using the muon device [UPDATE]

Muon investigations were conducted in March to July 2016 using a small muon tomography measurement device and the conditions inside the PCV were evaluated. In the muon investigations, a small device was used which was based on the same principles used in the device for Unit-1 investigations. Figure 3-15 shows the muon device used, and Figure 3-16 shows its location for the measurements.

[28] Handout document 3: Action progress towards decommissioning of Units 1 to 4 of Fukushima Daiichi Nuclear Power Station, 23rd Decommissioning and Contaminated Water Response Team Joint Meeting, October 29, 2015



Muon measurement device  
(small type: about 1m x 1m x 1.3mH)

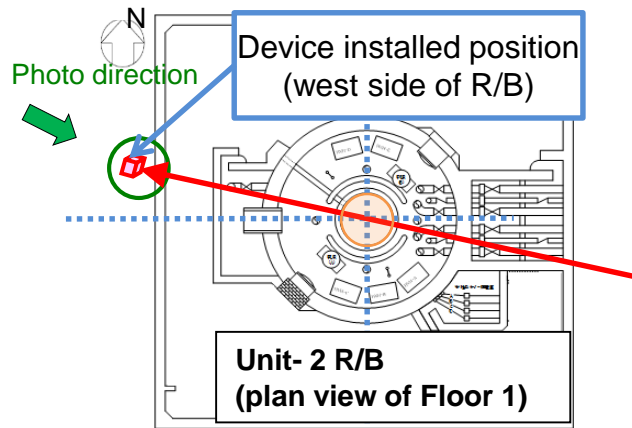

Figure 3-15 Muon measurement device [29]

Figure 3-16 Measurement device location [29]

Figure 3-17 shows the analysis results of material quantities (density length) obtained from the muon measurements (left) and the enlarged portion of the RPV lower part (right). Besides the PCV and fuel in the SFP, dark tones were identifiable in the RPV lower part, too, indicating the presence of high density materials. Evaluation by muon technologies becomes difficult below about O.P. 15m due to reduced muon population detectable, but the dark tones at the RPV lower part can be believed to be significant, since those in the PCV at a similar elevation are identifiable.

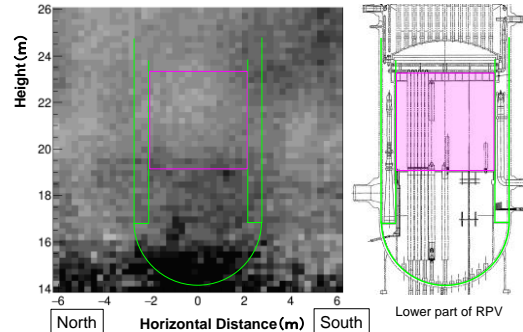
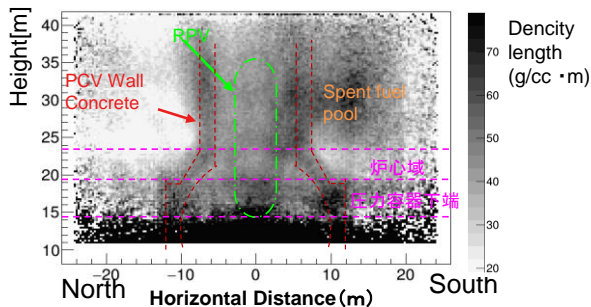

Figure 3-17 Distribution map of material quantities by muon measurements [29]

Figure 3-18 compares the results of measurements and simulation. In the simulation, two cases were assumed: one was the case in which high density materials (2 g/cc, 6 g/cc) simulating nuclear fuel were present in each evaluation region; and the other is the case in which they were not present. From the comparison, it was estimated that nuclear fuel had been present in the peripheral region of the core lower part and in the RPV bottom part, where the measured results had been closer to the results simulating the presence of high density materials there.

The results of quantitative evaluation of material quantities in the RPV are compared in Figure 3-19 with the material quantities before the accident. Most of the fuel debris was estimated to be

[29] Handout document 3: Action progress towards decommissioning of Units 1 to 4 of Fukushima Daiichi Nuclear Power Station, 32nd Decommissioning and Contaminated Water Response Team Joint Meeting, July 28, 2016

present at the RPV bottom.

- In-RPV material distribution evaluation by comparing simulation results and the measured muon populations

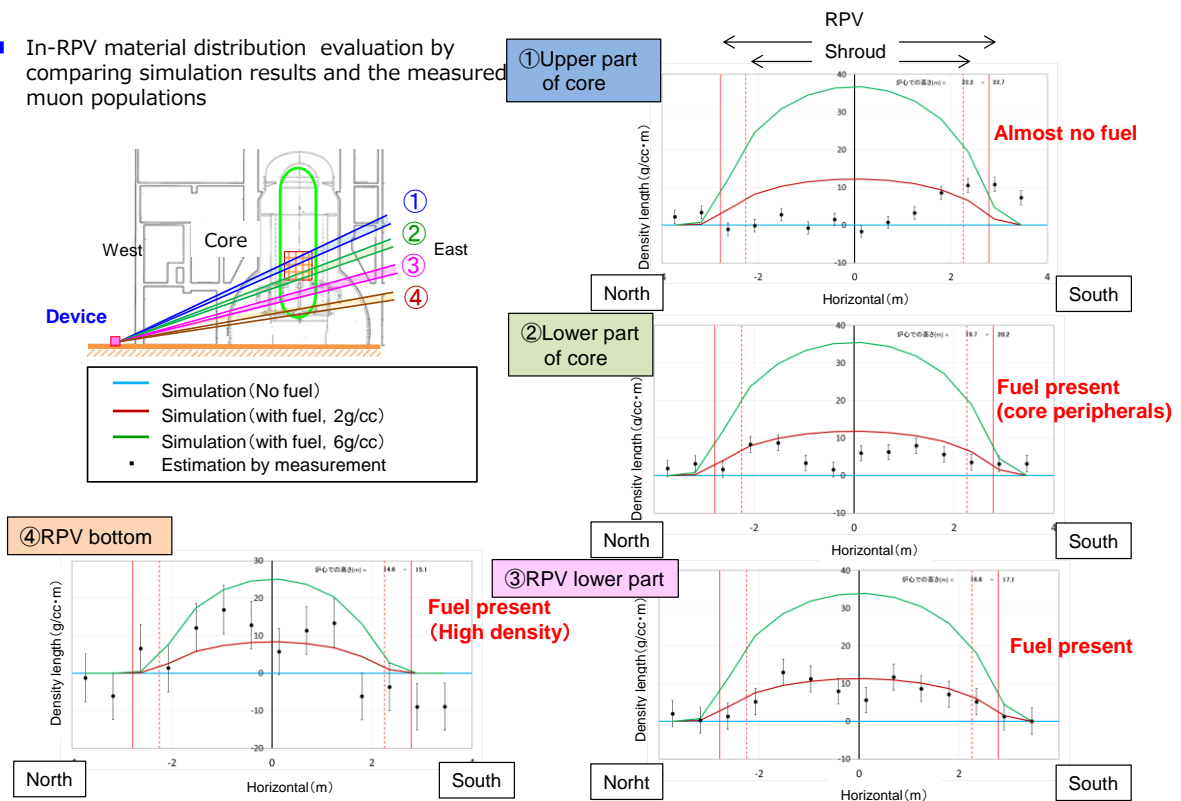
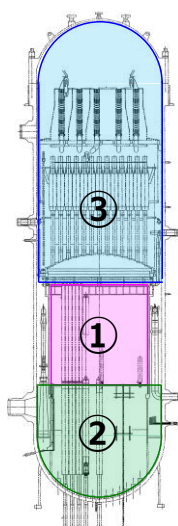

Figure 3-18 Material quantities distribution in RPV [29]



<Quantitative Evaluation Results>

	Evaluation results [ton]		(Reference) quantities before the accident* [ton]
① Core region (Inside shroud)	Approx. 20~50	Uncertainties in evaluation results: About several tens of tons	Approx. 160 (Fuel assemblies) Approx. 15 (Control rods)
② Bottom of RPV	Approx. 160		Approx. 35 (Structures) Effect of water is non-consideration
① + ②	Approx. 180~210		Approx. 210
(Reference) ③ Upper part of RPV	Approx. 70~100		Approx. 80 (Structures)

\*Weights in design. They do not necessarily agree with the muon results because part of the structures was ignored for simplicity and the muon measurements were performed looking upward and in the tilt direction.

Figure 3-19 Results of quantitative evaluation of material quantities in RPV [29]

(10) Investigation of in-PCV conditions of Unit-2 [UPDATE]

The inside of the pedestal was observed on January 30, 2015 with a pan-tilt camera mounted on

a guide pipe, as a preparatory survey for the investigation using the self-propelled investigation device. Figure 3-20 presents an integrated photo combining pieces of images taken by the camera after image processing for clarification. When referred to the similar arrangement at Unit-5 shown in the figure (left), the grating of Unit-3 can be found to be missing. At and above the place, cable-shaped fallen objects, and other fallen objects looking like TIP guide-tubes have been identified.

Figure 3-21 is a photo of the upper part inside the pedestal. Damaged portions of the local power range monitoring system (LPRM) and control rod position indicator probe (PIP) cables can be identified. PIP cables and LPRM cables can be located at some places but cannot be located at other places. Figure 3-22 summarizes damage conditions in the pedestal, investigation results of cables in the upper part of inside the pedestal and other findings.

From February 7 to 9, 2017, attempts were made to remove sediments on the CRD replacement rail using the sediment removing equipment. Figure 3-23 is the photo taken by the camera mounted on the equipment. The sediments were mixtures of black paste-like materials, thin fragmented objects, and pebble-shaped objects. The sediments became more sticky and difficult to remove when the equipment approached the pedestal from the PCV penetration. On February 16, 2017, the self-propelled investigation device was sent in for investigation. The equipment failed to reach inside the pedestal, but could collect data on temperatures, dose rates and conditions of structures around it.

Figure 3-24 shows the dose rates at 4 points obtained in this investigation. Around the pedestal opening, the dose rates inside the pedestal were lower than outside.

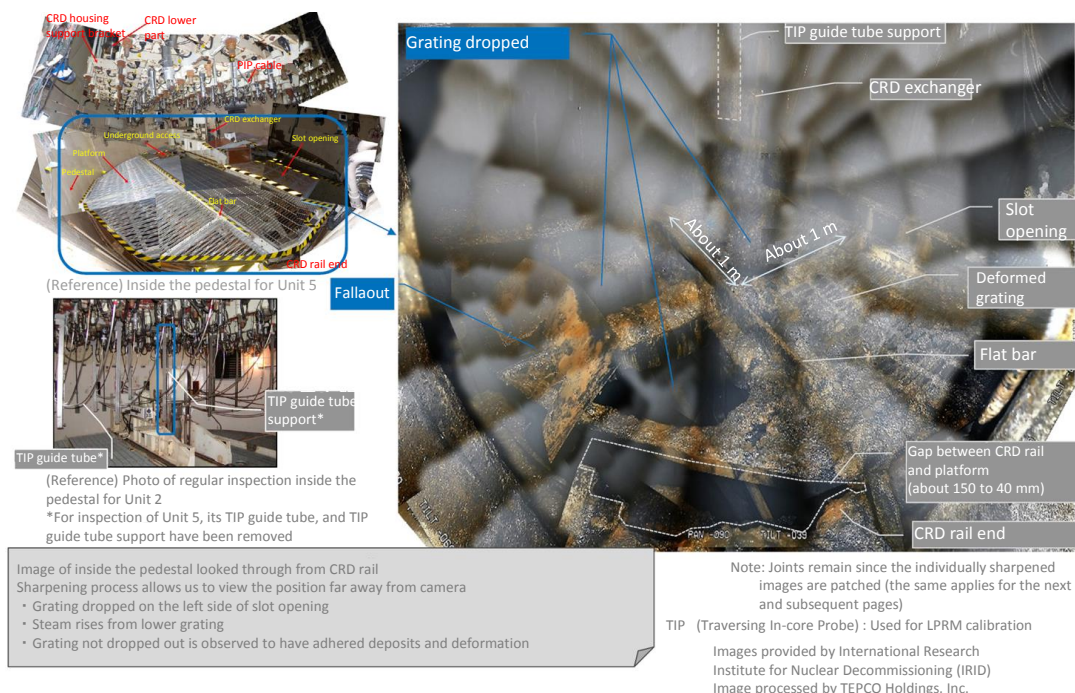

Figure 3-20 Conditions in the pedestal [30]

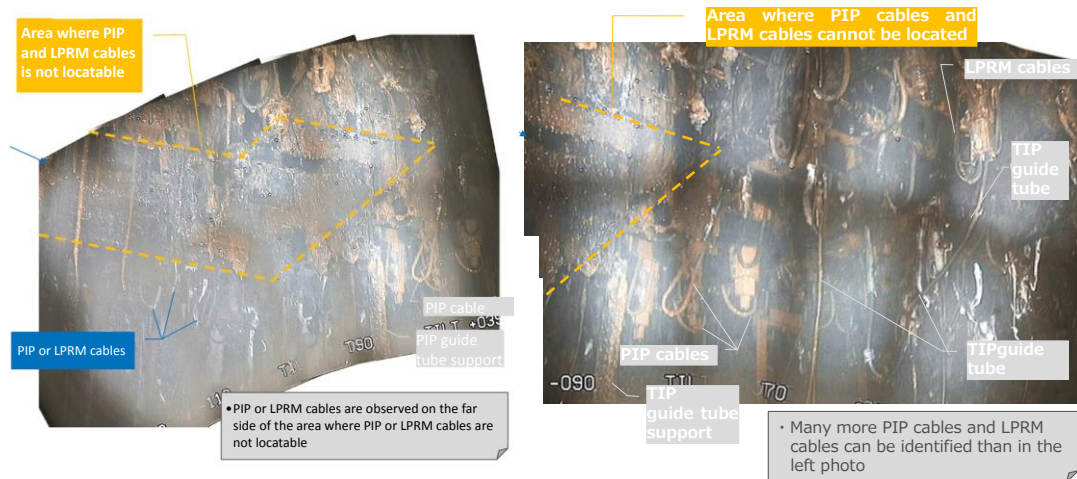

Figure 3-21 Conditions in the upper pedestal

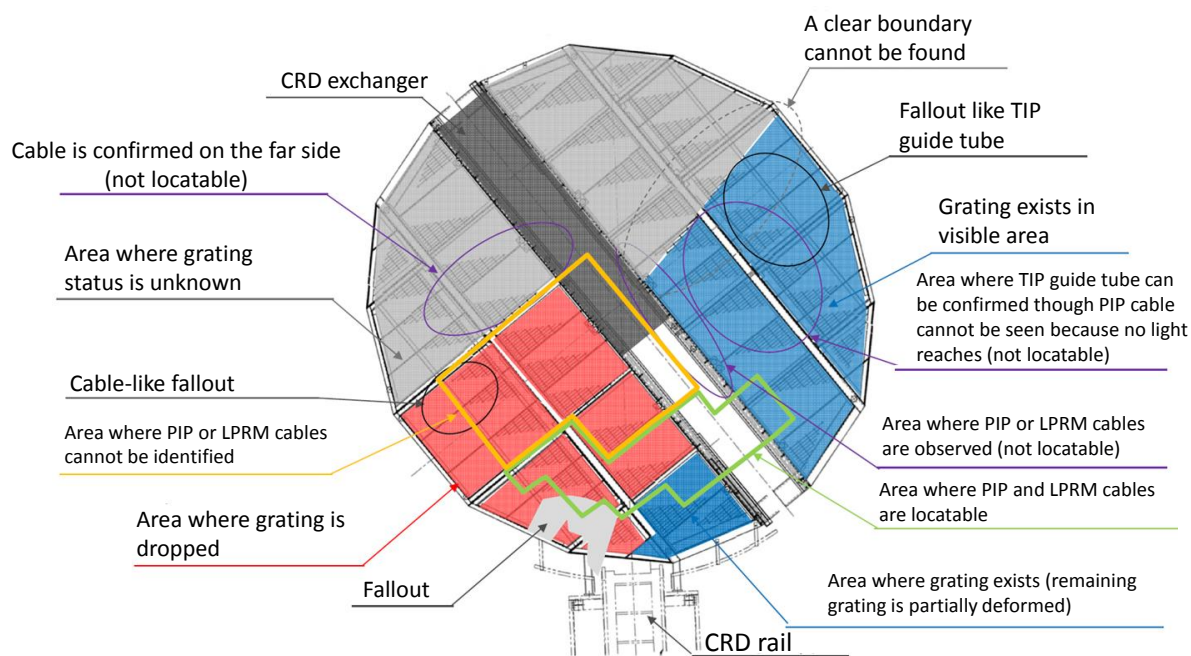

Figure 3-22 Conditions in the pedestal (summary) [30]



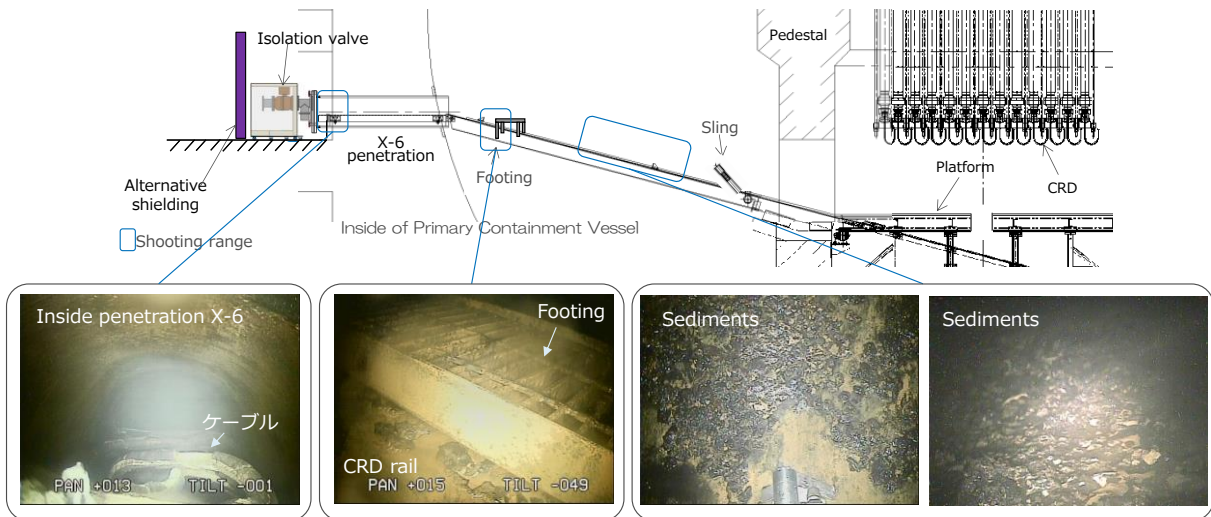

Figure 3-23 Images on the CRD rails starting from the X-6 penetration [31]

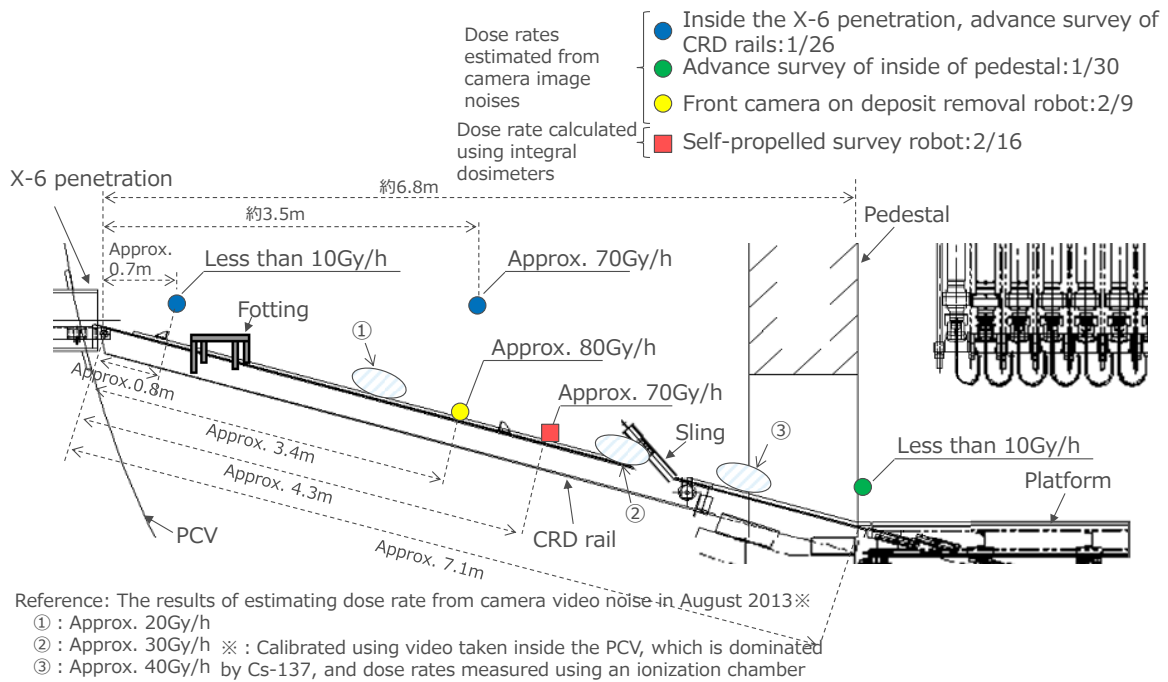

Figure 3-24 Dose rates measurement [32]

[31] Handout document 3: Action progress towards decommissioning of Units 1 to 4 of Fukushima Daiichi Nuclear Power Station, 39th Decommissioning and Contaminated Water Response Team Joint Meeting, February 23, 2017

[32] Handout document 3: Action progress towards decommissioning of Units 1 to 4 of Fukushima Daiichi Nuclear Power Station, 44th Decommissioning and Contaminated Water Response Team Joint Meeting, July 27, 2017

#### 4. Conditions of Unit-3 core and PCV

##### (1) Investigation of torus room

In the Unit-3 torus room investigation in July 2012, a robot accessed the gallery inside. Videotaping, dose rates measurement, acoustic checks, etc. were also carried out to the extent possible [33].

No water leaking position in the S/C was located yet. At least, no leak was confirmed on the flange, etc. of the S/C manholes, as far as the camera photos show (Figure 4-1).

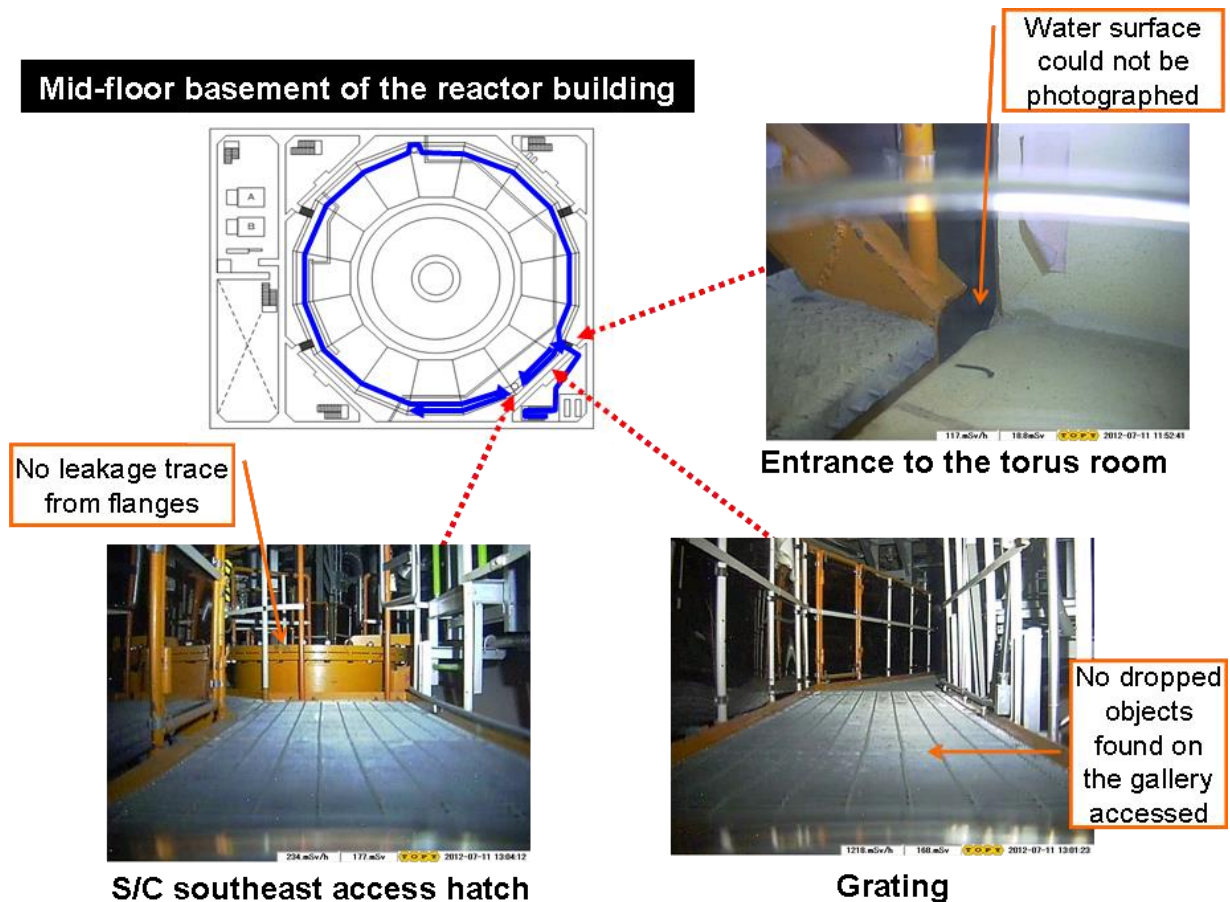

Figure 4-1 Camera photos in the torus room of Unit-3 (part)

##### (2) Oxygen concentrations in the PCV

Nitrogen is being sent to the PCV in order to maintain an inert atmosphere, while the containment gas control system discharges the same amount of gas from the PCV. It was confirmed through analyzing the discharged gas that the oxygen concentrations in the PCVs of Unit-1 and Unit-2 were nearly zero, while that in Unit-3 was about 8% (July 2012 [34]), analyzed again in March and April of 2013). Containment pressures of Unit-1 and Unit-2 PCVs are at

[33] Handout document, 8th Steering Committee, Government – TEPCO Joint Board on Mid- and Long-term Response Policy, July 30, 2012

[34] "Conditions in the containment vessels based on the measurements of the atmospheric gases", Technical Workshop for the Accident of the Fukushima Daiichi Nuclear Power Plant, July 23, 2012

several kPa, and remaining positive, while the pressure of the Unit-3 PCV is almost constantly at the level of the atmospheric pressure. Consequently, the gas leak rate of the Unit-3 PCV was confirmed to be the highest.

(3) Survey results of leaked water in the MSIV room of Unit-3

In January 2014, while camera photos taken by the rubble and wreckage removal robot in the Unit-3 reactor building were being checked, water was seen to be flowing from near the main steam isolation valve (MSIV) room door in the northeast area of the reactor building first floor. The water was flowing towards a nearby floor drain funnel (Figure 4-2) [35].

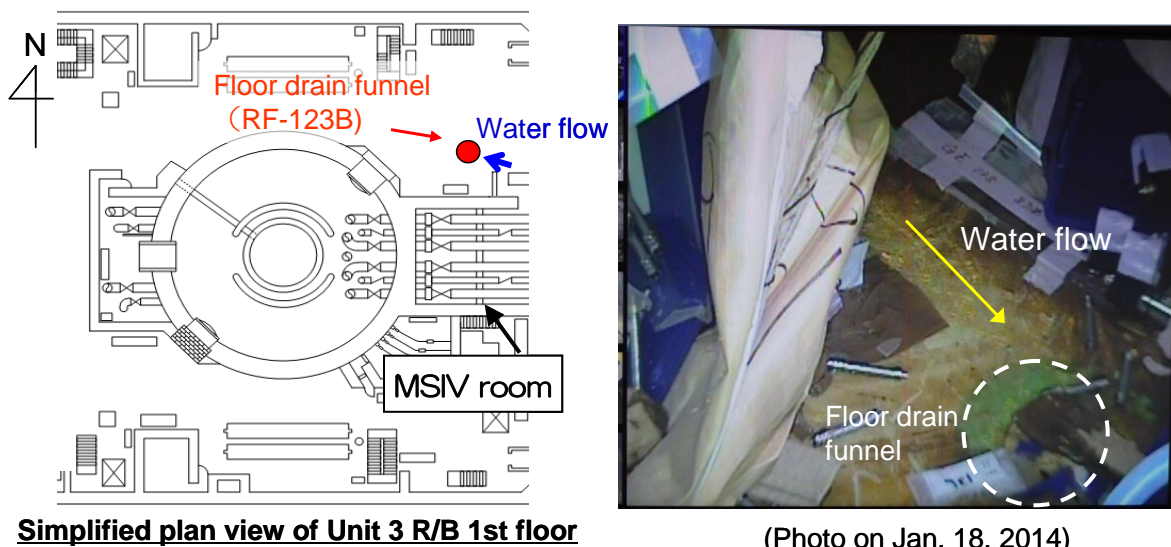
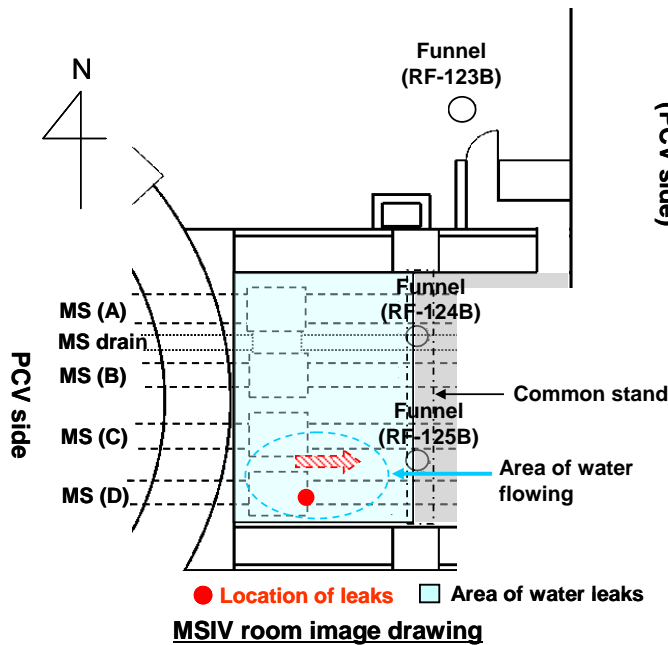
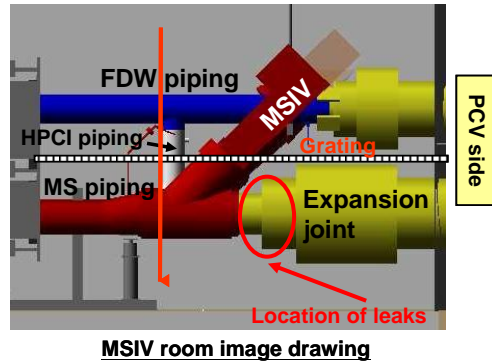
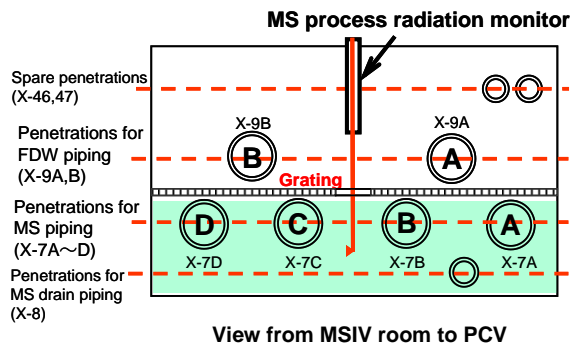
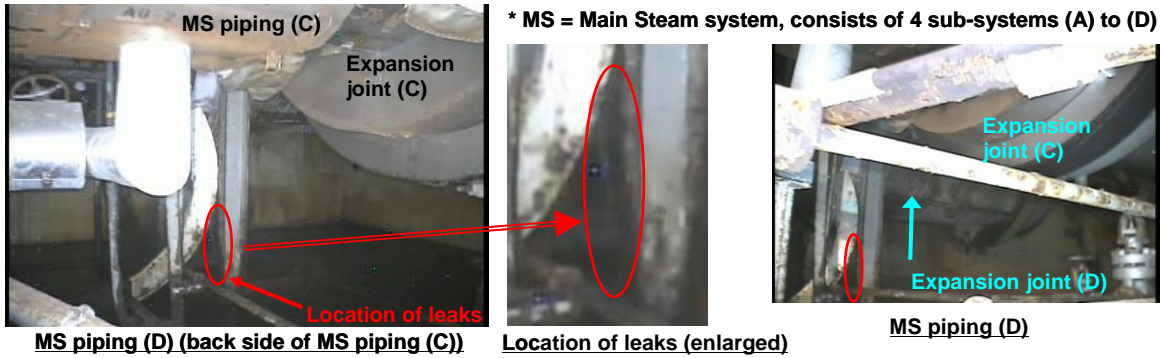

Figure 4-2 Water leak near the MSIV room door of Unit-3

The water level in the PCV is estimated as about OP.12 m (about 2 m above the reactor building first floor) by converting the S/C pressure obtained by the existing pressure indicators to water head. This elevation is on the level of PCV penetrations for main steam lines, thus indicating the possibility of water leaks from the PCV penetration in the MSIV room as the source of the water flow. In consideration of this possibility, instrumentation was inserted into the MSIV room from the HVAC system room on the floor above, in April and May 2014, and photos were taken and dose rates were measured in the room, in order to locate the water flows in the room. Water leaks were from near the expansion joint of main steam line D. It was concluded [36] that the leakage had occurred only from the main steam line D, based on: (1) confirmation of no leaks from the main steam lines A, B and C, and their main steam drain pipes; and (2) the flow directions of leaked water on the floor.

[35] Handout document, Action progress towards decommissioning of Units 1 to 4 of Fukushima Daiichi Nuclear Power Station, 2nd Decommissioning and Contaminated Water Response Team Joint Meeting, January 30, 2014.

[36] Handout document, Action progress towards decommissioning of Units 1 to 4 of Fukushima Daiichi Nuclear Power Station, 6th Decommissioning and Contaminated Water Response Team Joint Meeting, May 29, 2014.



Northern floor side



Southern floor side

Figure 4-3 Water leaks from main steam line D in MSIV room

(4) Investigation of PCV equipment hatch of Unit-3

In order to locate the leak path from the PCV, the PCV equipment hatch on the R/B ground floor was investigated on September 9, 2015. In this area of the equipment hatch, it has been known from the earlier investigation (in 2011) that the shield plug, which was to be located in front of the equipment hatch during normal operation and be placed forward for maintenance during outage, was unexpectedly moved onto the rails and high dose rate water was confirmed to have been left

in the ditches for the shield plug rails and in their vicinities. A possibility was pointed out therefore that the water retained in the PCV had leaked out through the equipment hatch seals.

In the current investigation, a small camera was inserted through the space between the shield plug and the wall originally surrounding the shield plug and the equipment hatch conditions were surveyed. Figure 4-4 presents photos taken of the hatch and around it. No water leaks from the hatch were recognized and no deformation of the hatch itself was recognized, either. Furthermore, no damage was found on the materials for periodic inspections that had been stored in front of the equipment hatch. Rather, it was noticed that the surface coating on the equipment hatch had come off and fragments of coating and other things had been accumulated on the floor in front of the equipment hatch.

At the original location for the shield plug, water (raindrops or condensed dew) was dripping from above and the floor seemed wet. Water puddles were recognized in the ditches for the shield plug travelling rails.

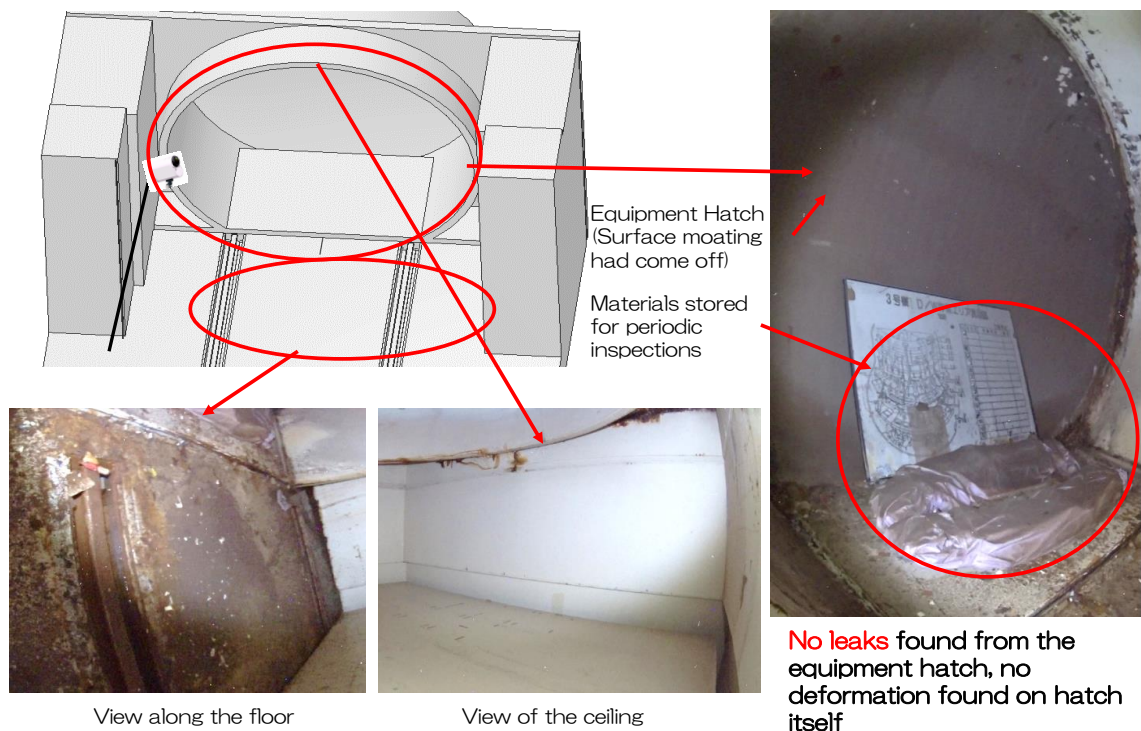

Figure 4-4 Photos of the equipment hatch [37]

#### (5) Investigation inside the PCV of Unit-3

The interior of the PCV of Unit-3 was investigated on October 20 and 22 by inserting an investigation probe through penetration X-53 for taking photos, checking water levels and measuring temperatures and dose rates. The retained water was sampled for water quality analysis.

Figure 4-5 shows photos of the penetration X-53 taken from the front. Structures like piping, a

[37] Handout document: Action progress towards decommissioning of Units 1 to 4 of Fukushima Daiichi Nuclear Power Station, 22nd Decommissioning and Contaminated Water Response Team Joint Meeting, October 1, 2015  
Attachment 4-45

ladder and other things were visible, but no damage was recognized. Including the underwater photos, no damage was recognized in the PCV in the current investigation.

Photos taken from the front

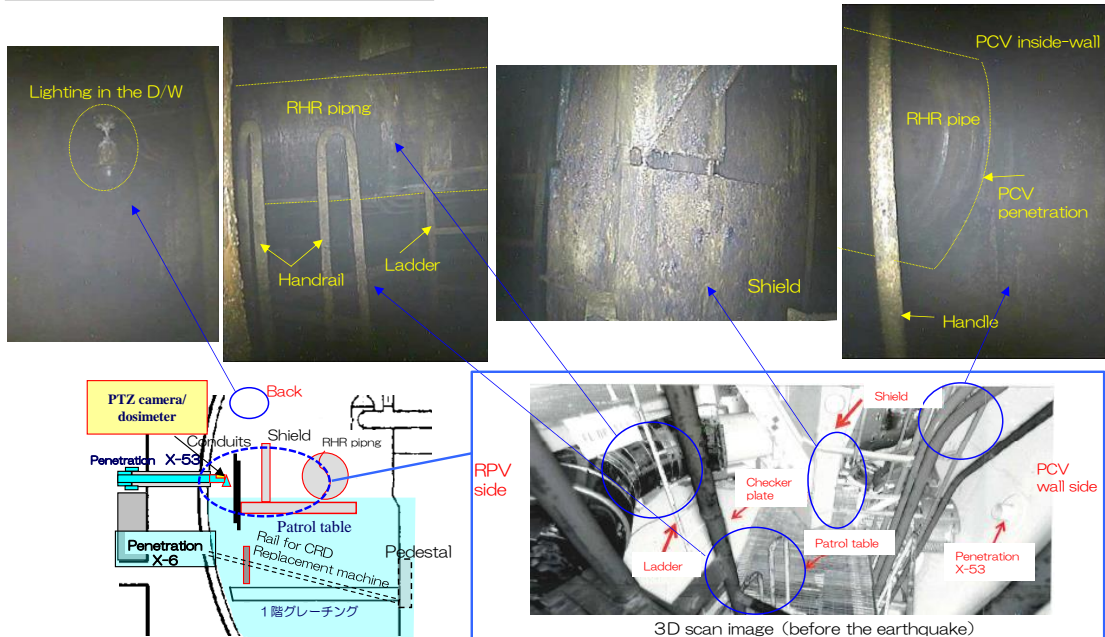

Figure 4-5 Photos of penetration X-53 taken from the front [38]

Figure 4-6 shows photos taken underwater by a PTZ camera. The camera was inserted through penetration X-53. Sediments were recognized on the grating and the rails for the CRD replacement machine.

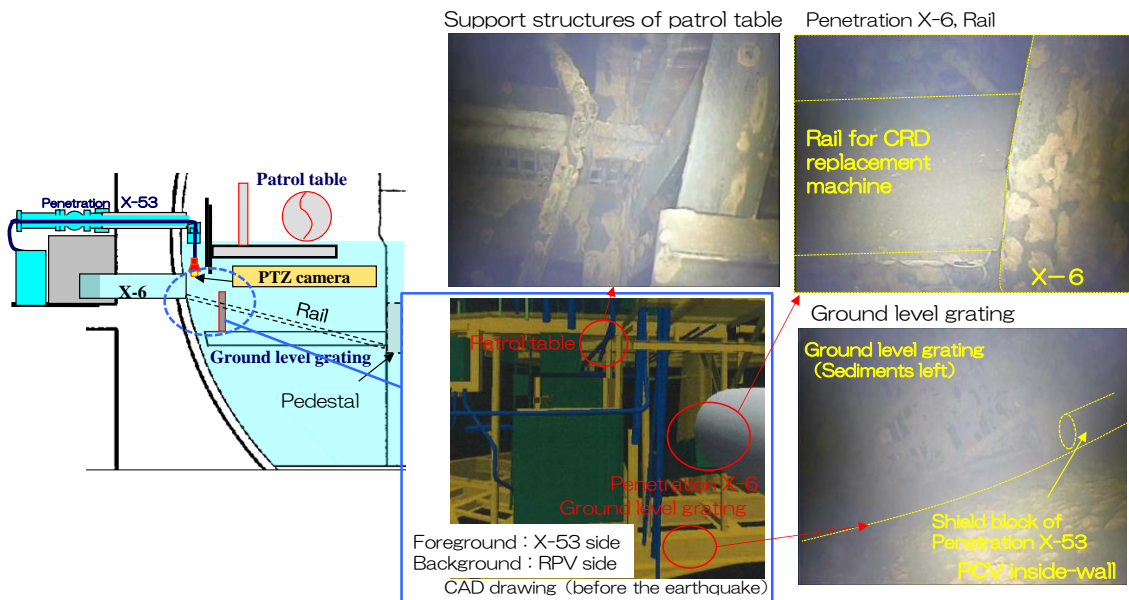

Figure 4-6 Photos in the water retained in the PCV [39]

[38] Handout document 3: Action progress towards decommissioning of Units 1 to 4 of Fukushima Daiichi Nuclear Power Station, 23rd Decommissioning and Contaminated Water Response Team Joint Meeting, October 29, 2015

[39] Handout document 3: Action progress towards decommissioning of Units 1 to 4 of Fukushima Daiichi Nuclear Power Station, 23rd Decommissioning and Contaminated Water Response Team Joint Meeting, October 29, 2015

The level of the water retained in the PCV was about OP11,800 or about 70 cm below the penetration X-53. It was roughly in agreement with the value estimated from the PCV pressures. The temperatures in the PCV were about 26 to 27 deg C in the air and about 33 to 35 deg C in the water. The air dose rate measured in the PCV was about 0.75 Sv/h at a point about 55 cm from the exit of penetration X-53, and 1 Sv/h near the PCV inner wall.

The results of quality analysis of retained water that was sampled are given in Table 4-1. Samples were taken at two positions, one about 10cm below the surface and the other about 70 cm below it. The results showed that the water was not strongly corrosive. In the water,  $\alpha$ -emitting nuclides were detected in addition to cesium and tritium.

Objective	Items of analysis (planned)		Near surface	About 70cm below surface	Evaluation
Corrosiveness of the environment	pH		6.8	6.3	Not strongly corrosive
	Conductivity ( $\mu$ S/cm)		14.0	10.2	
	Chlorine concentration (ppm)		Below detection limit (<1)	Below detection limit (<1)	
Radioactive materials released, nuclide migration behavior	$\gamma$ -concentration (Bq/cm <sup>3</sup> )	<sup>134</sup> Cs	4.0E02	2.3E+02	
		<sup>137</sup> Cs	1.6E+03	9.4E+02	
		<sup>131</sup> I	Below detection limit (<8.1E+00)	Below detection limit (<5.3E+00)	
	Tritium concentration (Bq/cm <sup>3</sup> )		2.7E+02	1.6E+02	
	<sup>89</sup> Sr/ <sup>90</sup> Sr concentration (Bq/cm <sup>3</sup> )		<sup>89</sup> Sr: below detection limit (<8.4E+01) <sup>90</sup> Sr: 7.4E+03	<sup>89</sup> Sr: below detection limit (<8.1E+01) <sup>90</sup> Sr: 3.9E+03	
	Total $\alpha$ concentration (Bq/cm <sup>3</sup> )		2.1E+00*	9.7E+01*	

Table 4-1 Results of water quality analysis of the water retained in the PCV [39]

#### (6) Operating floor survey of Unit-3 reactor building

Gamma-ray spectra were measured, radiation source nuclides were identified, and source distribution was investigated in October 2015 [40] on the operating floor of the Unit-3 reactor

[40] Handout document 3: Action progress towards decommissioning of Units 1 to 4 of Fukushima Daiichi Nuclear Power Station, 24th Decommissioning and Contaminated Water Response Team Joint Meeting, November 26, 2015

building. The investigation was conducted to plan decontamination and shielding work, because high dose rates had remained despite decontamination by removing rubble, shaving or vacuum sucking. Collimators were used to measure gamma ray spectra only from below.

Figure 4-7 compares, as a typical example, the gamma ray spectra measured (blue points) at Location ⑭ in Figure 4-8 and the gamma ray spectra of a reference Cs-137 source (red points) obtained at the calibration facility. Relatively higher counting rates are observed in the Compton region in addition to the photo peaks due to Cs-134 and Cs-137 in the measured spectra for the operating floor. When the heights of photo peaks and Compton peaks are compared, the contribution of Compton effects is relatively higher in the measured spectra for the operating floor than in the spectra measured at the calibration facility using reference sources. Similar trends have been confirmed at the measurement locations of the operating floor other than ⑭. Higher contributions of Compton effect mean higher contributions of scattered gamma rays. Therefore, it is possible that higher contributions to the dose rates for the operating floor came from scattered gamma rays from the source deep under the floor surface.

Figure 4-8 shows the distribution of dose rates (relative) evaluated from the measured gamma spectra. Higher dose rates were observed at the periphery of the reactor well-cover (⑥, ⑨, ⑪, ⑱, ⑳) and at the slab interfaces (⑫, ⑯).

It should be noted that the gamma ray spectra measurement and scattered gamma simulation results [41] obtained by the Nuclear Regulation Authority had indicated the possibility of a high cesium concentration having been deposited on the back face of the shield plug.

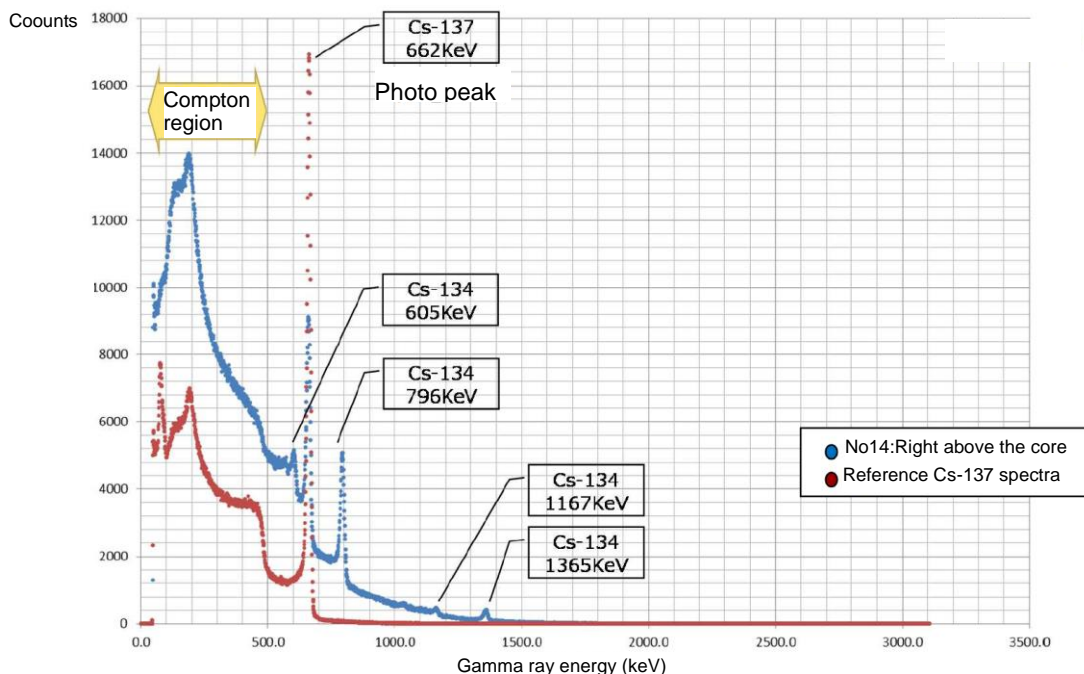
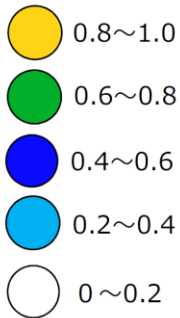

Figure 4-7 Gamma ray spectra measured (right above the core) [40]

[41] Handout document: Radiation Source Survey on the Operating Floor of Unit-3 Reactor Building (Newsletter), 38th Specific Nuclear Facility Supervising and Evaluation Committee Meeting, December 18, 2015



unit: - (normalized to 1.0 at point ⑳, where the spectrum area is the maximum)



\* Data at ㉞ ignored, because the measured dose rates were outside the measurement limit and not correctly measured

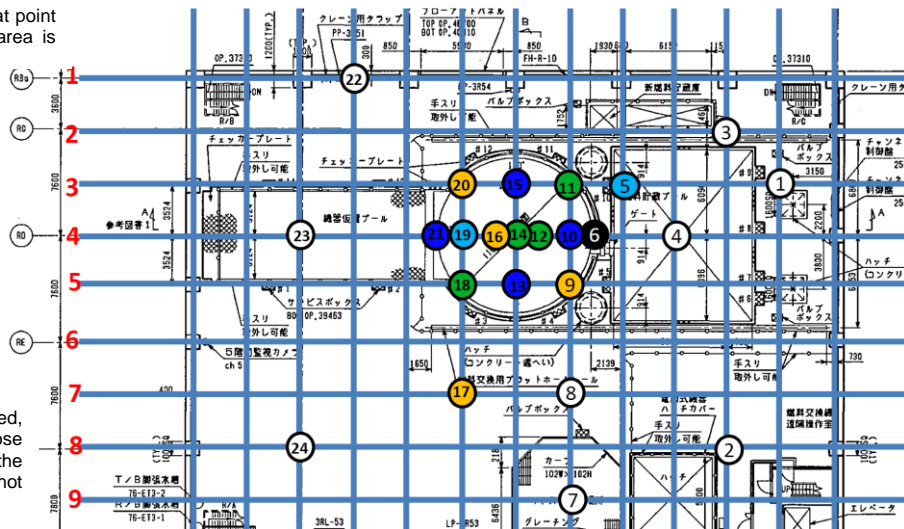

Figure 4-8 Dose rate distribution (relative)  
(Normalized to 1.0 at Location ⑳) [40]

(7) Investigation inside the PCV of Unit-3

(Investigation of conditions inside the pedestal using an underwater ROV) [UPDATE]

The inside of the Unit-3 pedestal was photo-surveyed in July 2017 by an underwater remotely operated vehicle (underwater ROV). Figure 4-9 shows a schematic diagram of the investigation. The underwater ROV was sent through a PCV penetration (X-53) to survey inside the PCV where it moved through the water taking photos and video films.

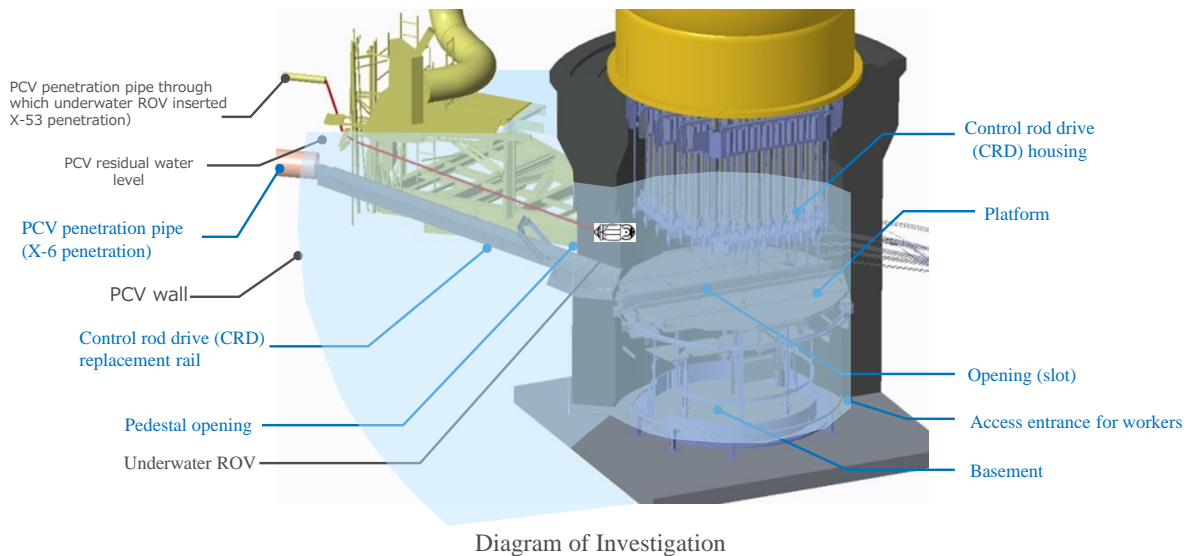

Figure 4-9 Schematic diagram for investigation inside the Unit-3 PCV [42]

The video camera filmed the CRD housing from below in Areas A1 and A2 inside the pedestal shown in Figure 4-10. Figure 4-11 and Figure 4-12 show photos taken. Figure 4-11 confirmed the CRD flanges were disarrayed; they should have been in place at uniform intervals and with the same elevation. Figure 4-12 confirmed an object looking like a control rod (CR) guide tube, which is part of the core internals and should be in the RPV, was now outside the RPV. Near the CRD housing damaged or fallen-off CRD housing support brackets were confirmed, and solidified molten objects were stuck to CRD flanges or other pieces. In Figure 4-11, ripples on the water surface, which could be photographed when looking from below toward the water surface, could be confirmed. This indicated a possibility that water was dripping from above. Similar water surface ripples could be confirmed near the pedestal inner wall, too. This indicated a possibility that, besides an opening at the center of RPV bottom head, another opening might exist in the RPV peripheral region, too.

---

[42] Handout document 3: Action progress towards decommissioning of Units 1 to 4 of Fukushima Daiichi Nuclear Power Station, 48th Decommissioning and Contaminated Water Response Team Joint Meeting, November 30, 201

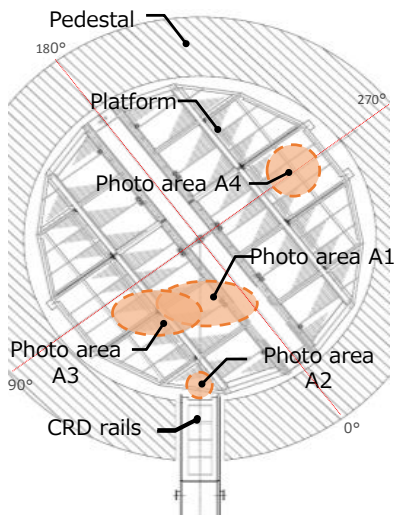

Figure 4-10 Photo area near CRD housing [42]

Photo area A1 (camera direction, upward)

Levels and intervals of two adjacent CRD flanges not uniform

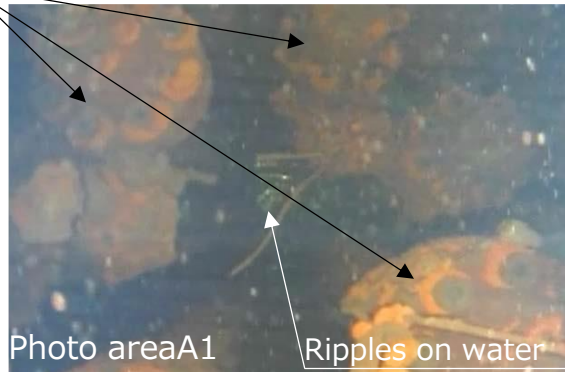

Figure 4-11 Camera photo [42]  
(CRD flange photo taken near CRD housing, photo area A1)

Photo area A3 (camera direction, upward)

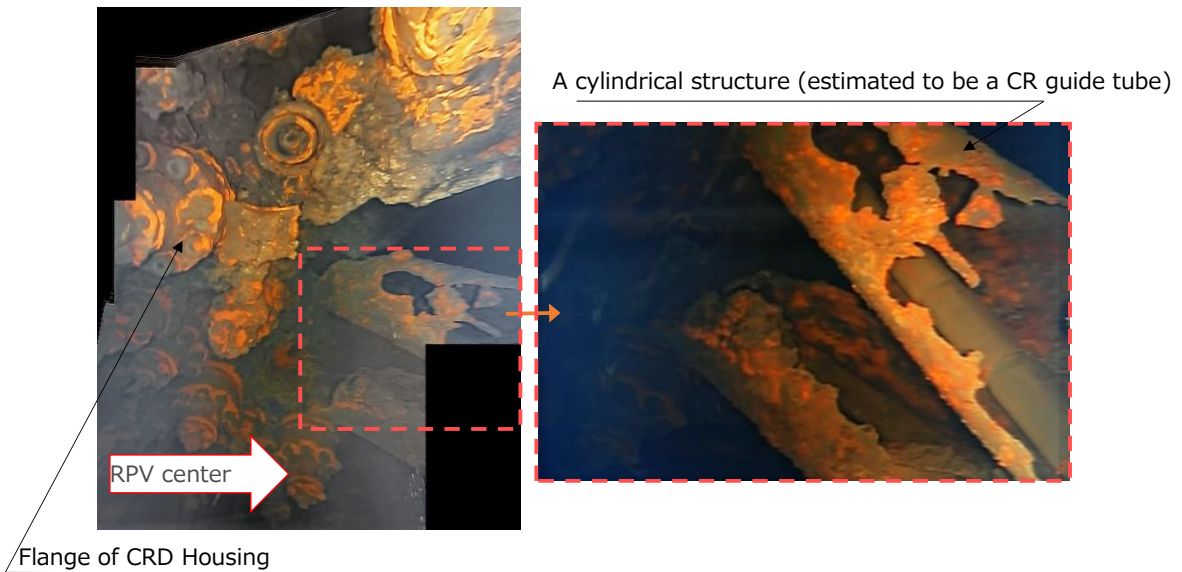

Figure 4-12 Camera photos  
(A structure, apparently a CR guide tube, photo taken near CRD housing in photo area A3) [42]

Figure 4-13 and Figure 4-14 are photos of the pedestal inner wall. On part of the inner wall, the epoxy-based coating was stripped off and the wall surface was rough, but no big pedestal damage or deformation was confirmed as a whole (Figure 4-13). Part of the cables for the RPV bottom thermometers laid on the pedestal inner wall was found to be missing (Figure 4-14). It is estimated that high temperature molten debris deposited on the cables when falling down.

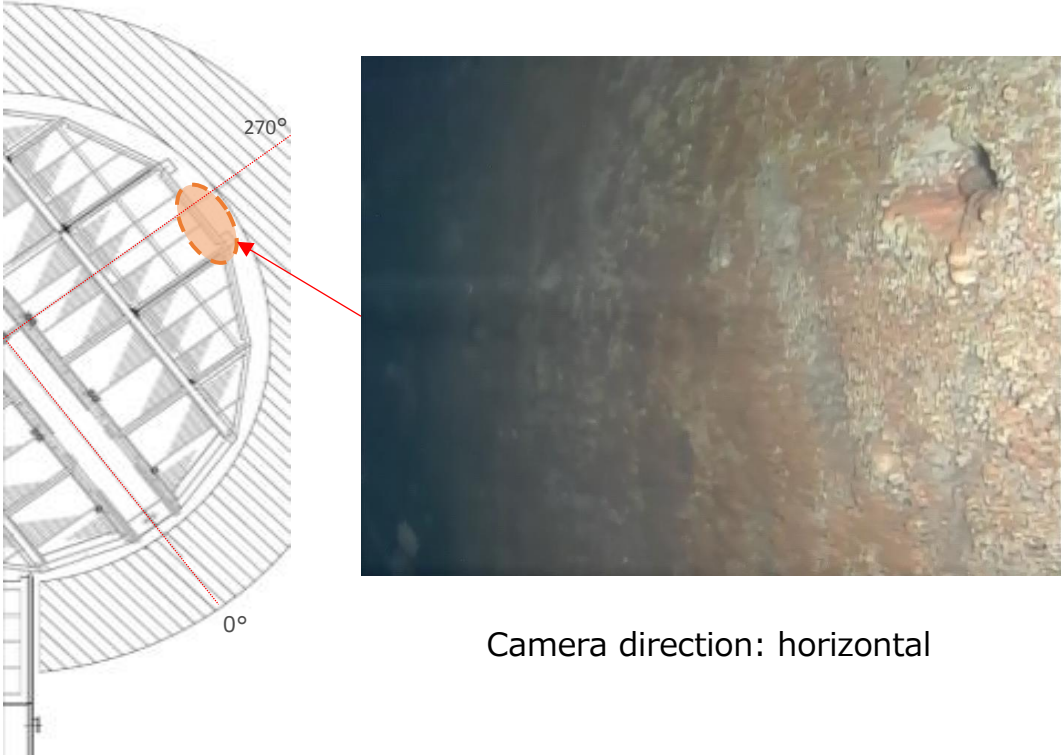

Figure 4-13 Camera photo (pedestal inner wall) [42]

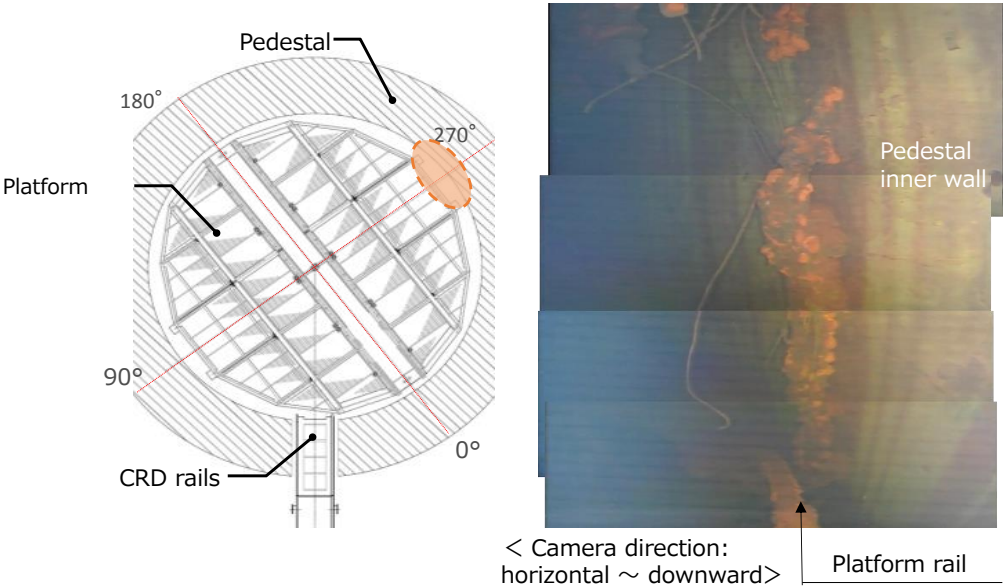

Figure 4-14 Camera photo (cables on the pedestal inner wall)

Figure 4-15 and Figure 4-16 are photos taken at a lower part inside the pedestal. Although not clearly identifiable, fallen objects looking like upper tie-plates of fuel assemblies or fuel support fitting plugs (Figure 4-15), or a control rod falling speed limiter (Figure 4-16) were found. In the pedestal lower part, pebble-like or lump sediments were confirmed besides sand-like sediments (Figure 4-16). The opening in the pedestal basement for human access was not checked visually, but sediments were confirmed to be present in the vicinity.

Photo taken by a back-side camera  
<Camera direction: horizontal>

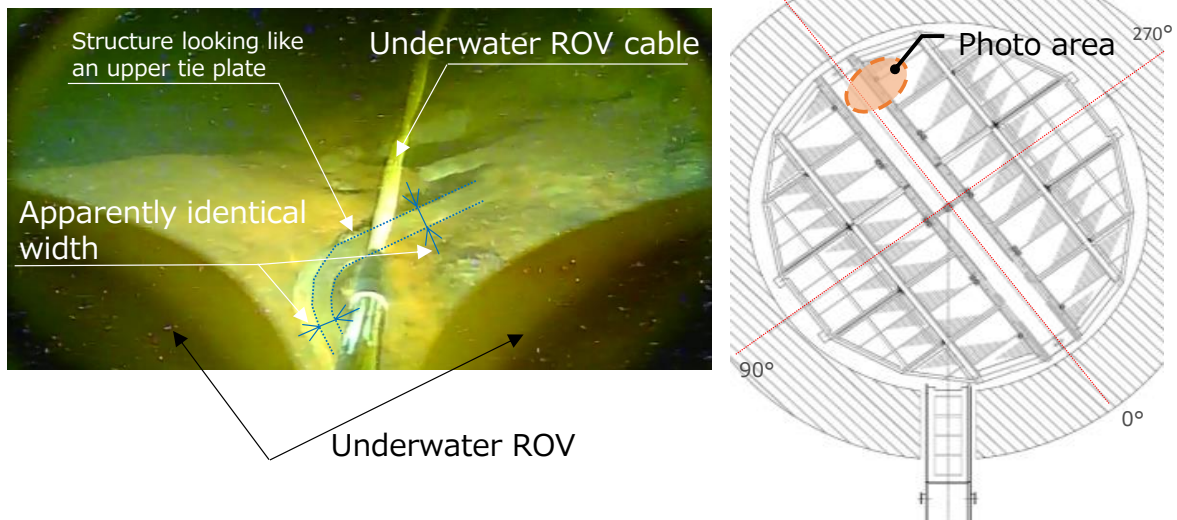

Figure 4-15 Camera photo

(A structure, possibly an upper tie-plate observed inside the lower pedestal) [42]

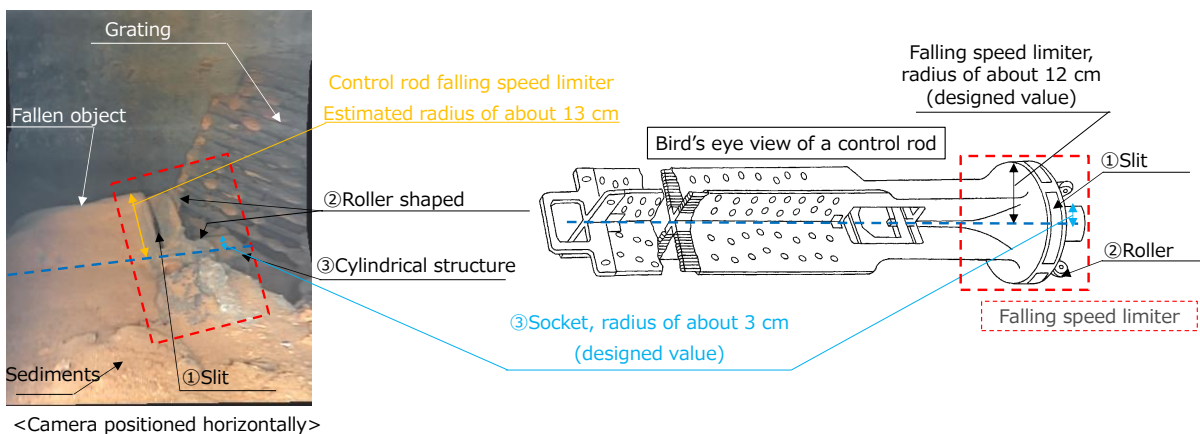

Figure 4-16 Camera photo

(A fallen object, possibly a control rod falling speed limiter observed inside the lower pedestal, Area C2) and schematics of a control rod [42]

(8) Investigation of Unit-3 with the muon device [UPDATE]

Investigations with the muon device were conducted for Unit-3 in May to September 2017 following the investigations for Unit-1 and Unit-2. Figure 4-17 shows the location where the muon device was set up. Figure 4-18 compares the distribution of material quantities (density length) obtained from a simulation based on design and those obtained from muon measurements. Concrete in the PCV peripherals, spent fuel pool and reactor building walls could be identified in the distribution of material quantities from the muon measurements.

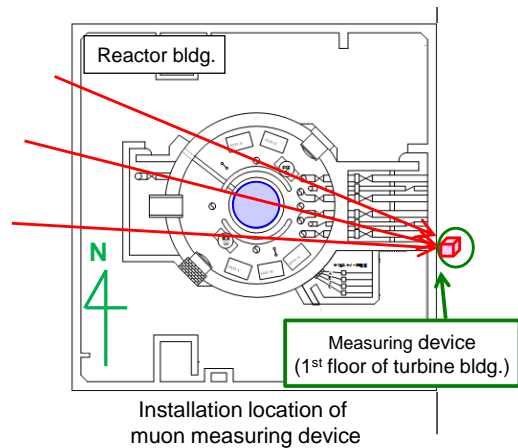

Figure 4-17 Location of muon device [43]

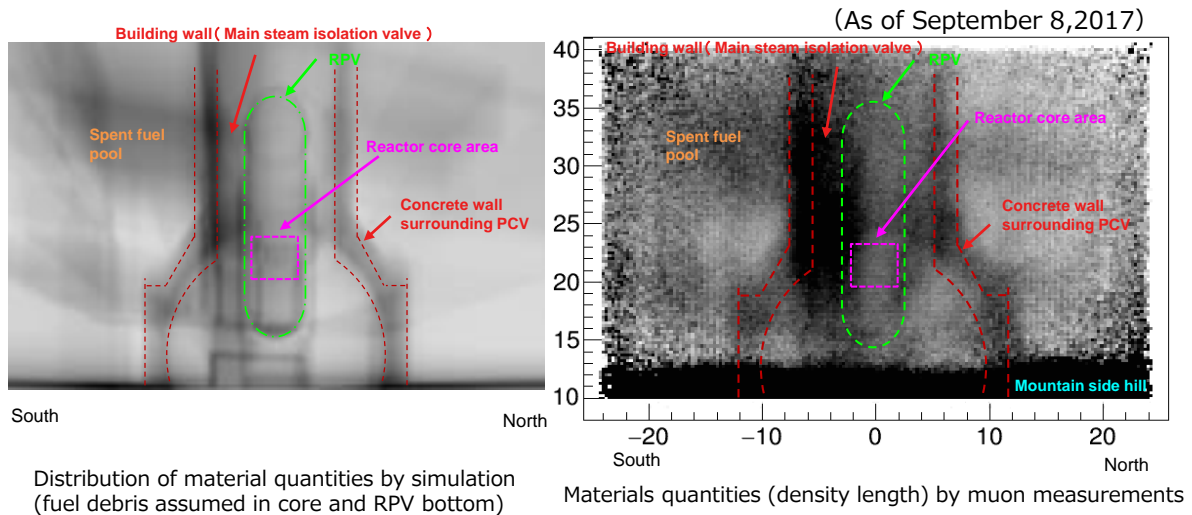

Figure 4-18 Distribution of material quantities from simulation (left) and muon measurement (right) [43]

The distribution of material quantities in the RPV was derived from the measured results by eliminating the influences from structures like R/B walls and the PCV based on the simulation model. The results are given in Figure 4-19 (left). These were compared with the simulation results, in which high density materials ( $3 \text{ g/cm}^3$ ,  $1 \text{ g/cm}^3$ , and in addition  $5 \text{ g/cm}^3$  at the PCV bottom) were assumed to be present in the RPV or not present. The comparison led to the estimation of the presence of fuel materials at different RPV elevations (Figure 4-19 (right)). Materials of about  $1 \text{ g/cm}^3$  or below were present at the core region, far lower than the normal average densities in the core (about  $3 \text{ g/cm}^3$ ). On the other hand, more material quantities were identified than normal in

[43] Handout document 3: Action progress towards decommissioning of Units 1 to 4 of Fukushima Daiichi Nuclear Power Station, 24th Decommissioning and Contaminated Water Response Team Joint Meeting, September 28, 2017

some part of the bottom of the RPV. Quantitative evaluation results of material quantities are given in Figure 4-20 for respective positions in the RPV. By considering the big reduction of material quantities in the core region as compared with those before the accident, most of the fuel can be estimated to have been relocated downward together with structural materials. No big fuel debris is considered to be left in the core region. To the contrary, the material quantities at the RPV bottom increased from the quantities before the accident. This is an indication, with some uncertainties being admitted, that part of the fuel debris remains at the RPV bottom.

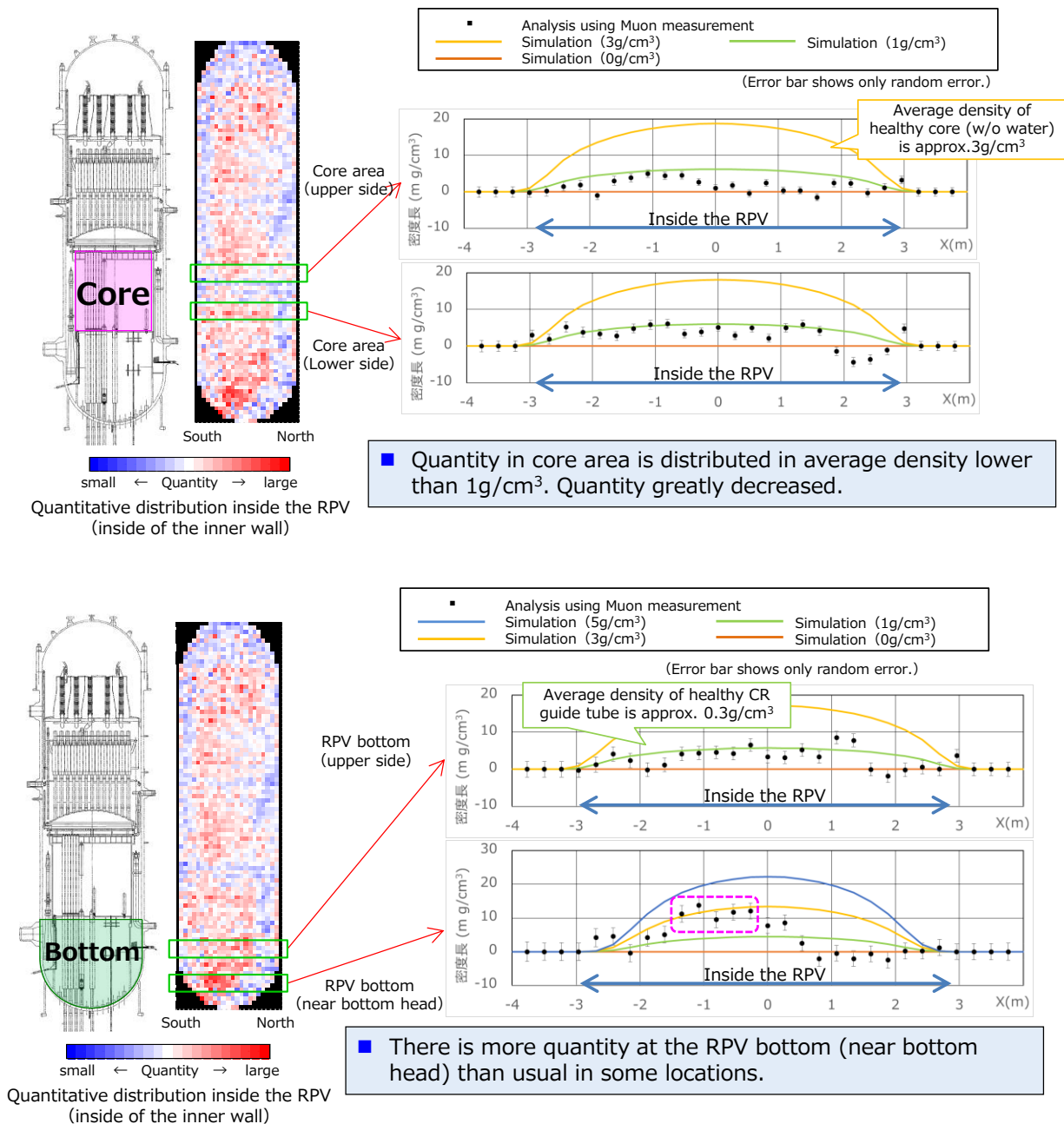
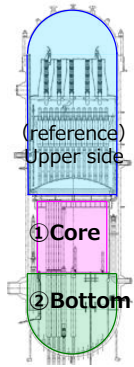

Figure 4-19 Distribution of material quantities in the RPV (Top: core region, Bottom: RPV bottom) [43]



<Result>

(As of September 8, 2017)

	quantity [ton]	Error [ton]		(Reference) quantity before the accident[ton]
		Random error	Systematic error	
(Reference)Upper side	Approx.120	±Approx.6	Dozens	Approx.80 (structures)
① Core area	Approx.30	±Approx.3		Approx.160 (fuel assembly) Approx.15 (control rod) Approx.35 (constructions)
② Bottom of the RPV	Approx.90	±Approx.5		Approx.35 (constructions) Without effect of water

Figure 4-20 Quantitative evaluation of material quantities in the RPV [43]