

2012
**TEPCO
ILLUSTRATED**

49786279980164304548678670464687671

2799801643045486



CONTENTS

I. Outline of the Comprehensive Special Business Plan	
1. The Future Direction of the "New TEPCO"	1
2. The Schedule towards Reformation	3
<Reference> Management Streamlining Measures	4
II. TEPCO Outline	
1. TEPCO Service Area	5
2. Company Highlights	6
(1) Company Highlights	6
(2) Business Scale Developments	7
(3) Business Scale by Area	8
(4) Comparison of TEPCO with 10 Japanese Electric Power Companies (total) and World Major Power Companies	9
a. Position of TEPCO in Japanese Electric Power Industry	9
b. Major Electric Power Companies in the World	9
c. Business Highlights for All Japanese Electric Power Companies	10
3. Organization Chart	12
III. Power Demand	
1. Changes in Japan's GDP and TEPCO's Power Demand	14
(1) Changes in Japan's GDP and TEPCO's Power Demand	14
(2) Average Rates of Increase in GDP, Final Energy Consumption, Electricity Sales, and Peak Demand	15
(3) Recent Changes in GDP Elasticity	15
(4) Electric Curve of Large Industrial Power as Diffusion Index	16
(5) Electrification Rate (primary energy supply base)	17
2. Electricity Sales	18
(1) Changes in Electricity Sales and Number of Customers (FY2005 - FY2011)	18
(2) Changes in Electricity Sales and Number of Customers (FY2000 - FY2004)	19
(3) Changes in Electricity Sales and Number of Customers (until FY1999)	20
(4) Changes in Percentage Composition of Large Industrial Power Customers by Industry Type	22
(5) Residential Customer Power Demand Changes in Energy Consumption and Contract Power per Household (Monthly average in the TEPCO service area)	23

3. Peak Demand	24
(1) Changes in Peak Demand (daily peak at generation end)	24
<Reference> Recent Changes in Peak Demand	25
<Reference> Peak Demand in Major Countries	26
(2) Trend of Monthly Peak Demand (daily peak at generation end)	27
(3) Pattern of Daily Electricity Usage (dates of annual peak demand recorded)	28
(4) Peak Demand in Summer and Annual Load Factor	29

IV. Electricity Supply Facilities

1. Power Generation Facilities	30
(1) Power Generation (authorized capacity)	30
<Reference> Special Note on Power Generation Facility	30
(2) Generation Capacity by Energy Source	32
a. Generation Capacity by Energy Source (TEPCO only)	32
b. Generation Capacity by Energy Source (TEPCO including purchased power)	32
<Reference> Combining of Energy Sources to Meet Changing Demand	33
c. Power Source Shares by Country	34
d. Development Status of Overseas Business	36
(3) Major Power Generation Facilities	38
a. Hydroelectric Power (with a capacity of more than 50MW)	38
b. Thermal Power	39
c. Nuclear Power	40
d. New Energy	40
(4) Electricity Generated and Purchased	41
(5) Changes in Power Output Composition by Energy Sources (TEPCO including purchased power)	42
a. TEPCO	42
b. 10 Electric Power Companies	43
(6) Electric Power Development Program	44
a. Demand Outlook	44
b. Peak Demand Outlook	44
<Reference> Summary of Power Plant Siting Procedure (example of nuclear power station)	45
(7) Wide Area Coordination System Operation	46
a. Purpose	46
b. Recent Situations	46
<Reference> Classification of Power Exchange	46
c. History of Wide Area Coordination System Operation at TEPCO	47

d.	Current Situation of Interconnection for Wide-Area Operation	48
(8)	Summary of Bid System for Wholesale Supply of Electric Power	49
a.	Screening Results	49
b.	List of Successful Bidders	49
c.	IPP Power Supply Procurement (procurement amount: total and by fiscal year)	50
2.	Transmission and Distribution Facilities	51
(1)	Transmission / Underground Transmission	51
a.	Transmission Facilities by Voltage	51
b.	Underground Transmission Line Installation Rate	51
	<Reference> IMV Designed Power Transmission Lines	
	(UHV: Ultra High Voltage lines)	52
(2)	Substation Facilities	53
(3)	Distribution Facilities	54
a.	Number of Supports and Transformers for Distribution Facilities	54
b.	Underground Distribution Line Installation Rate	54
3.	Forced Outages	55
	<Reference> Changes in Single-Phase Three-Wire Facility Installation Rate	
	for Lighting Service (TEPCO).....	55

V. Fuels

1.	Fuel Consumption (Thermal power)	56
2.	Crude Oil / Heavy Oil	57
(1)	Crude Oil Purchase and Consumption	57
a.	TEPCO's Crude Oil Purchase and Consumption	57
b.	Total Crude Oil Purchase and Consumption for 10 Electric Power Companies	57
(2)	Heavy Oil Purchase and Consumption	57
a.	TEPCO's Heavy Oil Purchase and Consumption	57
b.	Total Heavy Oil Purchase and Consumption for 10 Electric Power Companies	57
(3)	Yearly Changes in Crude Oil CIF Pricing	58
	<Reference> Monthly Changes in Crude Oil Pricing	58
3.	LNG	59
(1)	LNG Purchase and Consumption	59
a.	TEPCO's LNG Purchase and Consumption	59
b.	Total LNG Purchase and Consumption for Electric Power Suppliers	59
(2)	TEPCO's LNG Contract Summary (long-term contracts only)	60
4.	Coal	62
(1)	TEPCO's Coal Purchase and Consumption	62
(2)	Total Coal Purchase and Consumption for 10 Electric Power Companies	62

VI. Nuclear Power

1. Nuclear Power Generation	64
(1) General Data on Nuclear Power Plants in Operation	64
(2) Nuclear Power Plant Capacity Factor Trend	66
(3) Nuclear Power Plant Performance	67
(4) Problem Occurrence	
Problems to be Reported in Accordance with the Electricity Utilities Industry Law and the Law on the Regulation of Nuclear Source Material, Nuclear Fuel Material and Reactors	68
(5) Annual Production of Solid Radioactive Wastes	69
<Reference> Units of Radioactivity and Radiation	70
<Reference> Radiation Doses and Their Physical Effects	71
2. Nuclear Fuel Cycle	72
(1) Outline of Nuclear Fuel Cycle Facilities	72
(2) Japan's Procurement of Uranium (as of March 2010)	73
(3) Amount of Spent Fuel Storage	74
a. Amount of Spent Fuel Storage	74
b. Outline of Operation Auxiliary Common Facility (Common Pool) at Fukushima Daiichi Nuclear Power Station	74
c. Outline of Spent Fuel Storage Cask at Fukushima Daiichi Nuclear Power Station	74
(4) Overview of Recycled Fuel Storage Center	75
(5) Current Status of Nuclear Fuel Reprocessing Contracts	76
(6) High-Level Radioactive Waste Storage Conditions	77
<Reference> Schedule of Geological Disposal Project	78
<Reference> Nuclear Fuel Cycle Concept	79

VII. Accounting

1. Profit and Financial Structure Improvement Targets	80
(1) Changes in Standard Profits	80
(2) Changes in ROA/ROE	80
(3) Changes in Outstanding Amount of Interest-Bearing Liabilities	81
(4) Changes in Shareholders' Equity Ratio	81
2. Balance Sheet	82
(1) Non-Consolidated	82
(2) Consolidated	83
3. Statement of Income	84
(1) Non-Consolidated	84
(2) Consolidated	85

4. Summary of Non-Consolidated Financial Results	86
5. Consolidated Statements of Cash Flow	87
6. Changes in Ordinary Income	88
(1) Non-Consolidated	88
(2) Consolidated	88
7. Changes in Capital	89
8. Changes in Number of Shareholders and Shares (including shareholders and shares less than one unit)	90
<Reference> Comparison with Other Industries as Ratio of Individual Shareholders and Ratio of Individual Stock Ownership (per unit)	90
<Reference> Current Distribution of Shares (per unit) by Owners	90
<Reference> Major Shareholders (top 10 shareholders)	91
9. Changes in Shareholders' Equity Ratio	92
<Reference> Shareholders' Equity Ratio, by Industry (FY2010)	92
10. Changes in Ratio of Recurring Profit to Capital Stock	92
11. Changes in Costs of Supplying Electricity	93
<Reference> Changes in Equipment Expenses and Fuel Costs per kWh of Electricity Sales	93
<Reference> Changes in Exchange Rate (Interbank Monthly Average)	94
<Reference> Annual Exchange Rate (Interbank)	94

VIII. Electricity Rates and Rate Systems

1. Electricity Rates	95
(1) Overall Electricity Rates for Residential and Power Services	95
(2) Electricity Rates Revision History	96
(3) Unit Price of Electricity (become effective on September 1, 2012)	98
(4) Formulas for Calculating Electricity Rates (Monthly Bills) under Major Contract Categories	104
(5) Fuel Cost Adjustment System	106
(6) Renewable Energy Power Promotion Surcharge (Renewable Energy Surcharge) based on the Feed-in Tariff Scheme for Renewable Energy and the Photovoltaic Power Promotion Surcharge (Solar Surcharge) based on the Surplus Electricity Buyback Program for Photovoltaic Power Generation	108
(7) Ratios of Electricity Bills to Household Expenses and Production Amount	111
a. Ratio of Electricity Bills to Household Expenses (all households nationwide)	111
b. Ratio of Electricity Bills to Production Amount (total for manufacturing industry sector)	111
c. Ratio of Electricity Bills to Production Amount (by industry)	111

<Reference> Comparison of Rate Increases for Electric Power and Other Public Services (in Tokyo Metropolitan 23 wards)	112
(8) Calculation Process of Electricity Rates	113
2. Electricity Rate Systems	114
(1) Number of Customers Served and Contract Power by Use	114
(2) Major Optional Tariffs for Low-Voltage Customers (Households, Stores, etc.)	115
(3) Feed-in Tariff Scheme for Renewable Energy (Effective from July 1, 2012)	116
a. Electric Power to be Purchased	116
b. Purchase Price and Purchase Period	116
(4) Wheeling Service	118

IX. Capital Investment and Financing

1. Changes in Capital Investment and Plans	119
2. Changes (Net Increase) in Plans for Raising Equipment Funds	120
(1) TEPCO	120
<Reference> Changes (net increase) in Plans for Raising Equipment Funds	120
(2) 10 Electric Power Companies	121
<Reference> Changes (10 electric power companies) in Plans for Raising Equipment Funds	121
<Reference> Changes in Private Sector Capital Investment	122
<Reference> Comparison of Investment by Industry (FY2011)	122
3. Changes in Amount of Corporate Bonds Issued	123
4. Balance of Corporate Bonds and Loans Payable	124
5. Changes in Materials Procurement Cost	124

X. Streamlining

1. Changes in Electric Power Sales per Employee	126
2. Thermal Power Generation Efficiency (LHV: Lower Heating Value)	127
<Reference> International Comparison of Thermal Power Generation Efficiency	127
3. Transmission and Distribution Loss Rate	128
4. Changes in Automatization Rate of Hydroelectric Power Stations and Substations	128

XI. Technology Development and Renewable Energy

1. Research and Development	130
(1) Main Themes of FY2012 Research and Development Plan	130
(2) Changes in Research and Development Expenditure	130

(3) Ratio of Research and Development Expenditure to Sales	131
(4) Changes in the Number of Patent Applications	131
2. Renewable Energy	132
(1) Sites Where TEPCO Has Introduced New Energy (as of the end of March 2012)	132
(2) Business Use Facilities (as of the end of March 2012)	133
<Reference> International Comparison of Solar Amounts and Wind Power Generation Installations in Major Countries	133
(3) Issues and TEPCO R&D Milestones	134
(4) Purchase of Surplus Power from Solar, Wind and Waste Power Plants	135
<Reference> Purchase of Electricity from Solar and Wind Power	135

XII. Environmental Protection Measures

1. Changes in SO _x and NO _x Emissions Intensity per Power Output from Thermal Power Stations	136
<Reference> CO ₂ Emissions per kWh of Electricity Usage (for Life Cycle CO ₂ by type of power source in Japan)	137
2. Changes in TEPCO's CO ₂ Emissions and Emissions Intensity	138
<Reference> List of CO ₂ Emission Factor for Each Company (FY2010)	138
3. Internal Environmental Costs (for TEPCO alone in FY2011)	139
4. TEPCO's Efforts Toward Recycling of Industrial Waste etc.	140
5. Overview of PCB Treatment Facilities	142

XIII. Energy Conservation and Recycling

1. Total Energy Efficiency of District Heating and Cooling (DHC) Services (within the TEPCO service area)	144
2. CO ₂ Emission per Amount of Heat Unit Sold in District Heating and Cooling (DHC) Services (within the TEPCO service area)	145
3. Energy-IIP Intensity by Industry	145
4. Energy Conservation for Major Household Electrical Appliance	146
(1) Breakdown of Energy Consumption by Electrical Appliance in Homes	146
(2) Data on Household Electrical Appliances	147

XIV. Related Businesses

1. Affiliated Companies	148
<Reference> Outline of TEPCO Gas Business	154

XV. Other Data

1. Energy Dependency of Major Countries (2009)	155
2. Composition of Primary Energy Sources in Major Countries (2009)	155
<Reference> Japan's Energy Self-Sufficiency Rate (2009)	156
<Reference> Self-Sufficiency Rate by Energy Source in Japan (2009)	156
<Reference> Import and Export of Electricity Related to France (2009)	156
3. Security Index of Various Countries (2009)	157
4. Changes in Japan's Crude Oil Imports and Security Index	158
5. Power Generation Cost per Power Source	159

We deeply apologize to the people of Fukushima and broader society for the tremendous amount of inconvenience and anxiety caused by the accident at Fukushima Daiichi Nuclear Power Station. In accordance with our Comprehensive Special Business Plan approved by the ministers in charge on May 9, 2012, we will do our very best to achieve compensation payouts with courtesy and compassion to those afflicted by the nuclear damage, implement steady reactor decommissioning, secure stable power supply and execute thorough business streamlining.

I. Outline of the Comprehensive Special Business Plan

1. The Future Direction of the “New TEPCO”

	Specific Actions
i) Fulfilling Our Responsibilities	<ul style="list-style-type: none"> ● Implement compensation payouts for those afflicted by the accident at Fukushima Daiichi Nuclear Power Station with courtesy and compassion. ● Steadily implement decommissioning measures per the mid-and-long-term roadmap. ● Implement consistent cost-cutting, and try to maintain the level of electric rates. ● Reaffirming our responsibility as a utility provider that contributes to both society and the economy while securing a stable power supply and the safety of our facilities.
ii) Promoting a Culture of Openness	<ul style="list-style-type: none"> ● Take to heart the concerns of the afflicted, our customers, and broader society. All employees will conduct their work from a customer point of view. All customer feedback received will be subsequently translated into detailed action with the results to be announced. TEPCO will also release easy-to-understand updated information in a timely fashion concerning compensation, decommissioning and electric rate revisions. ● In order to enhance objectivity and transparency, thorough management reforms such as the transition over to a “Company with Committees” and the appointment of a majority of directors from outside of TEPCO will be done.

	Specific Actions
ii) Promoting a Culture of Openness	<ul style="list-style-type: none"> ● Transition to an “In-house Company System” that will clarify the mission and cost structure of each sector. It will further enhance TEPCO’s sensitivity to cost issues, stimulate creativity and strengthen business transparency. ● By reviewing traditional trade relationships including trade with affiliates, and further disclosing information and expanding bidding opportunities, TEPCO will ensure fairness and transparency in its trading activities. ● To do away with “one-sidedness, excessive conservatism”, “sectionalism”, promote cross-sectional communication from management to the frontlines in consideration of societal expectations. Also promote active personnel exchanges and cross-sectional information sharing towards the establishment of an open-minded company culture.
iii) Reforming Energy Service in step with Customer and Societal Expectations	<ul style="list-style-type: none"> ● Given the tremendous changes in the power supply-demand balance following the earthquake, in order to optimize energy efficiency, we will reform the business as follows in consideration of customer and societal expectations. ● In order to improve the installation efficiency of the facilities, we must depart from our prior reluctance to seek outside support by forming partnerships with other organizations, actively incorporate new power sources and promote competition. ● Enhance neutrality and fairness in the network sector. In addition, via improving the efficiency and the reliability of the facilities utilizing ICT, we will establish a network that allows for the large-scale introduction of renewable energy and a dispersed power system. ● Increase the number of rate menus, further control peak demand and reduce electricity rates by actively developing energy management services through business alliances. Also increase customer options and respond to various needs via the active introduction of smart meters and new energy solutions etc.

<Reference> Management Streamlining Measures

		Emergency Special Business Plan (FY2011 - 2020)	Comprehensive Special Business Plan (FY2012 - 2021)
		Content (Issue)	Status of the achievement in FY2011
		Content (Issue)	
Cost Reductions	TEPCO Main Body	Cut ¥2,648.8 billion over 10 years	Although the original cost cut target was ¥237.4 billion, the actual projected cost cut amount will be ¥252.3 billion. (+ ¥14.9 billion)
	Reduction of Facility Investments	-	-
Asset Sales	Real Estate	Sell TEPCO Group property equiv. to ¥247.2 billion in principle by FY2013	Although the original sales target for TEPCO's main body assets (excluding group company assets) was ¥15.2 billion, actual projected sales amount will be ¥43.1 billion. (+ ¥27.9 billion)
	Securities	Sell TEPCO Group securities equiv. to ¥330.1 billion in principle by FY2013	Although the original sales target of TEPCO's main body assets was ¥300.4 billion, actual projected sales amount will be ¥314.1 billion. (+ ¥13.7 billion) (96% completion of the TEPCO Group total target by FY2013)
	Subsidiaries & Affiliate Companies	Sell 45 companies (equiv. to ¥130.1 billion) in principle by FY2013	Although the original sales target for TEPCO's main body assets was ¥32.8 billion, actual projected sales amount will be ¥47 billion (+ ¥14.2 billion)
		-	-

“Routine Streamlining”



“Structural Streamlining”

* The consolidated cost cut effect is equivalent to ¥115.3 billion taking into account the subtraction of the amount per TEPCO business transactions.

II. TEPCO Outline

1. TEPCO Service Area

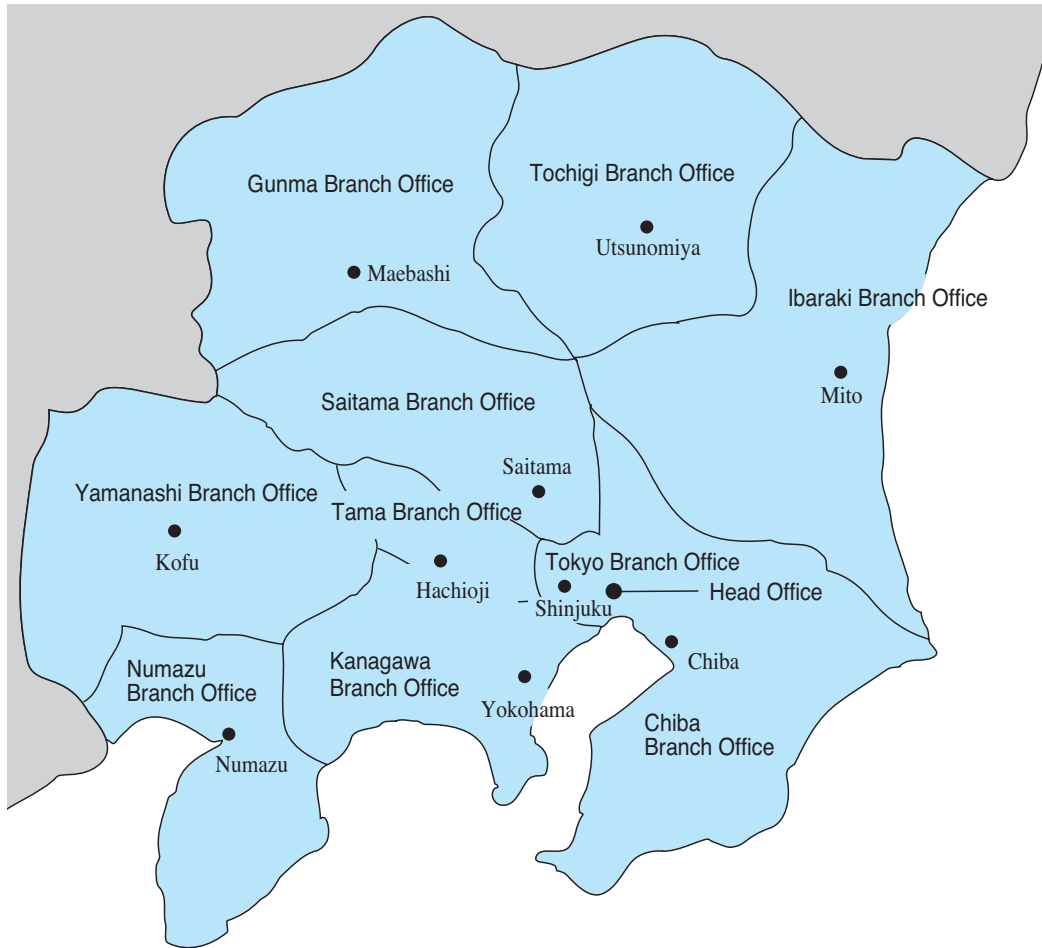

(Service Areas of the 10 Electric Power Companies in Japan)

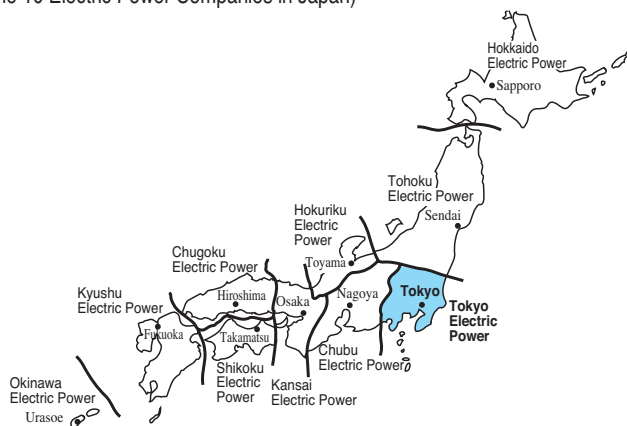

2. Company Highlights

(1) Company Highlights

- ❑ Capital stock: 1,400,975,722,050 yen (as of the end of July 2012)
- ❑ Total number of shares issued: 3,547,017,531 (as of the end of July 2012)
- ❑ Number of shareholders: 898,831 (as of the end of March 2012)
- ❑ Electricity sales: (FY2011)
 - For lighting: 95,797 GWh
 - For power: 172,433 GWh
 - Total: 268,230 GWh
- ❑ Peak demand: 64.30 GW (as of July 24, 2001)
- ❑ Number of customers (Period ended March 31, 2012 exc. specified-scale demand)
 - For lighting: 26.67 million • 96.09 GW
 - For power: 2.11 million • 14.39 GW
 - Total: 28.78 million • 110.48 GW
- ❑ Revenue from electricity sales: 4,754.0 billion yen (as of FY2011)
- ❑ Number of power stations and generation capacity (as of the end of March 2012)

Hydro:	163	8.982 GW
Thermal:	25	40.148 GW
┌ Oil		11.166 GW
└ Coal		1.600 GW
└ LN(P)G		27.382 GW
Nuclear:	3	17.308 GW*
New Energy, etc.	5	0.034 GW
Total:	196	66.472 GW
- ❑ Number of employees: 38,701 (as of the end of March 2012)

* On April 19, 2012, following the notification of decommissioning submitted on March 30, 2012 in accordance with Article 9 of the Electric Utilities Industry Law, Units 1-4 (2,812MW) at Fukushima Daiichi Nuclear Power Station were decommissioned.

As of the end of March 2012, the output of these units was included.

(2) Business Scale Developments

At the End of FY	1951	1955	1965	1975	1985	1995	2005	2007	2008	2009	2010	2011	Total of 10 EP Co. 2011
Capital Stock (billion yen)	1.4	13.1 (9.4)	120.0 (85.7)	400.9 (286.4)	650.0 (464.3)	676.4 (483.1)	676.4 (483.1)	676.4 (483.1)	676.4 (483.1)	676.4 (483.1)	900.9 (643.5)	900.9 [*] (643.5)	2,880.4
Revenue from Electricity Sales (billion yen)	25.8	57.6 (2.2)	274.7 (10.6)	1,249.6 (48.4)	4,032.3 (156.3)	4,900.6 (189.9)	4,682.0 (181.5)	4,914.7 (190.5)	5,295.9 (205.3)	4,504.5 (174.6)	4,796.5 (185.9)	4,754.0 (184.3)	14,472.4
Capital Investment (billion yen)	8.6	28.5 (3.3)	124.6 (14.5)	383.2 (44.6)	1,104.3 (127.9)	1,399.2 (162.7)	505.0 (58.7)	568.8 (66.1)	590.2 (68.6)	592.1 (68.8)	614.9 (71.5)	674.4 (78.4)	2,123.2
Utility Fixed Assets (billion yen)	77.0	165.3 (2.1)	643.4 (8.4)	1,778.8 (23.1)	6,360.4 (82.6)	9,654.5 (125.4)	9,154.9 (118.9)	8,416.0 (109.3)	8,159.5 (106.0)	7,871.7 (102.2)	7,673.2 (99.7)	7,440.5 (96.6)	23,934.2
Electricity Sales (TWh)	7.3	10.9 (1.5)	41.0 (5.6)	102.2 (14.0)	165.3 (22.6)	254.4 (34.8)	288.7 (39.5)	297.4 (40.7)	289.0 (39.6)	280.2 (38.4)	293.4 (40.2)	268.2 (36.7)	859.8
Generation Capacity (GW)	1.82	2.44 (1.3)	8.10 (4.5)	24.59 (13.5)	37.59 (20.7)	51.21 (28.1)	61.84 (34.0)	62.47 (34.3)	63.98 (35.2)	64.49 (35.4)	64.99 (35.7)	66.47 (36.5)	208.01
Number of Customers (million)	3.97	4.52 (1.1)	8.22 (2.1)	15.05 (3.8)	19.95 (5.0)	24.88 (6.3)	27.80 (7.0)	28.34 (7.1)	28.51 (7.2)	28.62 (7.2)	28.73 (7.2)	28.78 (7.2)	83.89
Number of Employees	29,274	29,453 (1.0)	37,724 (1.1)	38,341 (1.3)	39,058 (1.3)	43,448 (1.5)	38,235 (1.3)	38,234 (1.3)	38,030 (1.3)	38,227 (1.3)	38,671 (1.3)	38,701 (1.3)	123,936

- Notes:
1. Numerical data (Revenue from electricity sales and Electricity sales) for FY1951 include those of Kanto Haiden Kabushiki Kaisha for April 1951.
 2. Figures in parentheses are a multiplication unit with the reference value for FY1951 or the end of FY1951 being one.
 3. Figures for capital stock, revenue from electricity sales, capital investment, and utility fixed assets are obtained by omitting fractions smaller than 0.1 billion yen. Those for other items are obtained by rounding.
 4. * The Nuclear Damage Liability Facilitation Fund has paid a total of 1 trillion yen to acquire the preferred shares issued by TEPCO on July 31, 2012.
This resulted in a capital of 1,400.9 billion yen (500 billion yen increase).
 5. The number of employees is that of persons at work. The number of employees of TEPCO includes employees seconded to other companies and agencies.
 6. The number of customers of 10 electric power companies excludes those in the specific-scale demand and is based on electric service contracts.

(3) Business Scale by Area

(as of the end of FY2011)

Branch Offices	Area (km ²)	Population (million)	Number of Customers (million)	Electricity Sales (TWh)	Peak Demand		Service Centers	Generation Capacity (GW)				
					GW	Date		Hydro	Thermal	Nuclear	New Energy etc.	Total
Tochigi	6,413	2.01	1.32	16.5	2.86	1.20	3	2.206	-	-	-	2.206
Gunma	6,392	2.05	1.33	15.8	2.78	1.20	4	2.439	-	-	-	2.439
Ibaraki	6,116	2.97	1.95	24.3	3.99	7.18	4	-	5.400	-	-	5.400
Saitama	3,790	7.20	4.28	36.8	7.00	8.18	6	-	-	-	-	-
Chiba	5,136	6.23	3.90	35.9	6.12	2.16	5	-	17.792	-	-	17.792
Kanagawa	2,445	9.12	5.40	48.4	8.72	1.20	7	0.046	10.707	-	0.020	10.772
Yamanashi	4,323	0.86	0.66	6.0	1.14	2.20	2	1.055	-	-	0.010	1.065
Numazu	2,631	1.22	0.86	10.2	1.71	1.17	3	0.018	-	-	-	0.018
Tokyo 2 Branch Offices	2,263	13.07	9.08	74.2	14.59	8.18	11	0	2.450	-	0.004	2.454
Others								3.217	3.800	17.308 ^{*2}	-	24.325
Total	39,509 (10)	44.73 (35)	28.78	268.2 (31)	49.66 ^{*1} (34)	1.20	45	8.982 (25)	40.148 (32)	17.308 ^{*2} (37)	0.034 (6)	66.472 (32)
Total for Entire Nation (Total of 10 EP Co.)	377,955	127.73	83.89	859.8	156.60	8.10		35.602	125.483	46.343	0.580	208.008

- Notes:
1. New energy etc. consist of wind, photovoltaic, waste, geothermal and biomass power generation (facilities with expected supply capacity and TEPCO's approved facilities).
 2. Numazu refers to a part of TEPCO's service area on the east of the Fuji River in Shizuoka Prefecture. The data for TEPCO's two branch offices in Tokyo are based on the total of the Tokyo and Tama branch offices.
 3. Figures in parentheses represent the ratio (%) to the total for the entire nation (total for 10 electric power companies).
 4. The figures for TEPCO's area represent the total of the areas that its branch offices cover. The figure for total for the entire nation (total of the 10 electric power companies) is as of October 1, 2011.
Source: "Statistical Reports on the Land Area by Prefectures and Municipalities in Japan," Ministry of Land, Infrastructure, Transport and Tourism.
 5. Figures for peak demand represent peak demand recorded at the consumption end in the area that each branch office covers.
*1 The figure 49.66 does not agree with that for the total of peak demand recorded by each branch office because it represents the peak load registered by TEPCO as a whole (at the generation end).
 6. The number of customers of 10 electric power companies excludes those in the specific-scale demand and is based on electric service contracts.
 7. Totals in the table may not agree with the sums of each column because of being rounded off.
 8. Figures for service centers are as of March 31, 2012.
 9. The nationwide population figure is as of January 1, 2012. (Source: "Monthly Report on Current Population Estimates," Ministry of Internal Affairs and Communications.)
 10. *2 On April 19, 2012, following the notification of decommissioning submitted on March 30, 2012 in accordance with Article 9 of the Electric Utilities Industry Law, out of the nuclear plants owned by TEPCO, Units 1-4 (2,812MW) at Fukushima Daiichi Nuclear Power Station were decommissioned.
As of the end of March 2012, the output of these units was included.

(4) Comparison of TEPCO with 10 Japanese Electric Power Companies (total) and World Major Power Companies

a. Position of TEPCO in Japanese Electric Power Industry

(as of the end of FY2011)

	TEPCO Service Area (a)	Total Service Area of 10 EP Co. (b)	(a) / (b)
Population (million)	44.73	127.73	35.0%
Area (km ²)	39,509	377,955	10.5%
Population Density (persons/km ²)	1,132.1	338.0	334.9%
Electricity Sales (TWh)	268.2	859.8	31.2%
Peak Demand (GW)	49.66 ^{*1} <Jan. 20, 2012>	156.60 <Aug. 10, 2011>	31.7%
Capital Stock (billion yen)	900.9 ^{*2}	2,880.4	31.3%
Total Assets (billion yen)	15,149.2	42,466.4	35.7%
Gross Income (billion yen)	5,184.3	15,875.5	32.7%
Number of Customers (million)	28.78	83.89 ^{*3}	-

Notes: The nationwide population is as of January 1, 2012. (Source: "Monthly Report on Current Population Estimates," Ministry of Internal Affairs and Communications.)

The nationwide area is as of October 1, 2011. (Source: "Statistical reports on the land area by prefectures and municipalities in Japan," Ministry of Land, Infrastructure, Transport and Tourism)

*1 TEPCO's peak demand so far is 64.30 GW recorded on July 24, 2001.

*2 The Nuclear Damage Liability Facilitation Fund has paid a total of 1 trillion yen to acquire the preferred shares issued by TEPCO on July 31, 2012.

This resulted in a capital of 1,400.9 billion yen (500 billion yen increase).

*3 The number of customers of 10 electric power companies exclude those in the specific-scale demand and is based on electric service contracts.

b. Major Electric Power Companies in the World

(FY2011, or as of the end of FY2011)

Country	Utilities	Electricity Sales (GWh)	Total Assets ^{*1} (billion Yen)
U. S. A.	Exelon	169,843 ^{*2}	4,398.5
	Southern Company	159,702	4,731.9
	Duke Energy	140,231 ^{*2}	4,992.1
Germany	E. ON	314,700	16,987.1
	RWE	273,800	10,295.9
Italy	ENEL	311,800	18,868.7
Canada	Hydro-Québec	196,729	7,738.1
U. K.	Centrica	88,683	2,506.0
	Scottish and Southern Energy	51,900	2,520.9
France	EDF	433,000 ^{*3}	25,747.3
	GDF Suez	389,500 ^{*2}	23,714.1
Sweden	Vattenfall	137,500 ^{*2}	6,457.3
Japan	TEPCO	268,230	15,149.2
	Kansai Electric Power Co.	146,028	6,660.4
	Chubu Electric Power Co.	127,897	5,375.2

Notes: Figures for electricity sales (excluding wholesale and trading) include those sold to other countries. Total assets are consolidated figures for companies that incorporate a holding company system (other than for Japan).

*1 Converted at the rates of US\$1 = 79.84 yen; €1 = 111.12 yen; UK £1 = 128.06 yen; Canada \$1 = 80.80 yen; Sweden 1 krona = 12.31 yen

*2 Figures include the electricity sales for wholesale and trading.

*3 Domestic figures only.

Source: Annual Reports of the world's major electric power companies, etc.

c. Business Highlights for All Japanese Electric Power Companies

Item Electric Power Company	Capital Stock (Million Yen)	Total Assets (Million Yen)	Hydro		Thermal		Nuclear		
			No. of Power Stations	Maximum Output (MW)	No. of Power Stations	Maximum Output (MW)	No. of Power Stations	Maximum Output (MW)	
Hokkaido	114,291	1,553,474	53	1,237	11	4,065	1	2,070	
Tohoku	251,441	3,875,038	210	2,434	14	10,885	2	3,274	
Tokyo	900,975 ^{*1}	15,149,263	163	8,982	25	40,148	3	17,308 ^{*2}	
Chubu	430,777	5,375,261	183	5,218	11	23,969	1	3,617	
Hokuriku	117,641	1,358,137	128	1,905	6	4,400	1	1,746	
Kansai	489,320	6,660,484	150	8,197	12	16,907	3	9,768	
Chugoku	185,527	2,688,958	97	2,906	12	7,801	1	1,280	
Shikoku	145,551	1,313,106	58	1,141	4	3,797	1	2,022	
Kyushu	237,304	4,110,950	141	3,582	45	11,577	2	5,258	
Total of 9 EP Co.	2,872,827	42,084,671	1,183	35,602	140	123,550	15	46,343	
Okinawa	7,586	381,787	-	-	21	1,933	-	-	
Total of 10 EP Co.	2,880,413	42,466,458	1,183	35,602	161	125,483	15	46,343	
9 EP Co.	FY1951 or as of May 1, 1951	7,200	113,506	1,269	5,760	89	2,816	-	-
	2011/1951 (times)	399.0	370.8	0.9	6.2	1.6	43.9	-	-

- Notes:
1. New energy etc. consist of wind, photovoltaic, waste, geothermal and biomass power generation (facilities with expected supply capacity and TEPCO's approved facilities).
 2. Fractions smaller than one MW were rounded to the nearest whole number for maximum outputs. Maximum output of new energy etc. in Okinawa is stated as "a" since it is less than 1,000 kW.
 3. Electricity generated and purchased = power generated by their own + power purchased from other utilities + electricity exchanged (deducted) - power for pumped storage.
 4. Figures for electricity sales include those for business operations and construction work but exclude those for inter-company power sales and for power sales to other utilities (with fractions smaller than one GWh when rounded).
 5. *1 The Nuclear Damage Liability Facilitation Fund has paid a total of 1 trillion yen to acquire the preferred shares issued by TEPCO on July 31, 2012. This resulted in a capital of 1,400.9 billion yen (500 billion yen increase).
 6. *2 On April 19, 2012, following the notification of decommissioning submitted on March 30, 2012 in accordance with Article 9 of the Electric Utilities Industry Law, out of the nuclear plants owned by TEPCO, Units 1-4 (2,812MW) at Fukushima Daiichi Nuclear Power Station were decommissioned. As of the end of March 2012, the output of these units was included.
 7. Figures given for revenue from electricity sales exclude inter-company power sales and power sales to other utilities. Fractions smaller than a million yen are rounded down.
 8. The number of employees is that of persons at work. The number of employees of TEPCO includes employees on loan to other companies and agencies.
 9. in the above table indicates the item under which the utility holds first place among the ten electric power companies in Japan.
 10. Totals in the table may not agree with the sums of each column because of being rounded off.
 11. The number of customers is based on electric service contracts excluding those in the specified-scale demand. (Fractions smaller than a thousand customers are rounded to the nearest whole number.)

(FY2011, or as of the end of March 2012)

New Energy etc.		Total		Electricity Generated and Purchased (GWh)	Peak Demand (GW) <Date>	Electricity Sales (GWh)	Revenue from Electricity Sales (million yen)	No. of Customers (thousand)	No. of Employees
No. of Power Stations	Maximum Output (MW)	No. of Power Stations	Maximum Output (MW)						
2	51	67	7,424	36,473	<Jan. 12, 2011> 5.79	32,145	551,142	3,993	5,183
5	225	231	16,818	82,577	<Aug. 5, 2010> 15.57	75,304	1,292,712	7,618	12,342
5	34	196	66,472	290,814	<Jul. 24, 2001> 64.30	268,230	4,754,063	28,763	38,701
3	31	198	32,835	138,965	<Aug. 5, 2008> 28.21	127,897	2,161,606	10,490	15,845
5	7	140	8,058	31,884	<Aug. 5, 2010> 5.73	28,898	428,750	2,091	4,530
1	10	166	34,882	158,562	<Aug. 2, 2001> 33.06	146,028	2,338,679	13,513	20,484
1	3	111	11,989	65,585	<Aug. 17, 2007> 12.29	60,070	980,215	5,211	8,951
2	2	65	6,963	31,546	<Aug. 4, 2008> 5.99	28,444	466,219	2,844	4,570
8	216	196	20,633	92,493	<Aug. 1, 2008> 17.71	85,352	1,342,682	8,518	11,804
32	580	1,370	206,075	928,898	<Jul. 24, 2001> 181.25	852,368	14,316,068	83,040	122,410
1	a	22	1,933	8,440	<Aug. 3, 2009> 1.54	7,440	156,741	851	1,526
33	580	1,392	208,008	937,338	<Jul. 24, 2001> 182.69	859,809	14,472,809	83,891	123,936
-	-	1,358	8,576	41,207	<Dec. 26, 1951> 6.36	30,382	109,891	15,717	136,851
-	-	1.0	24.0	22.5	28.5 (2001/1951)	28.1	130.3	5.3	0.9

Sources: "Electric Power Statistics" (from the website of the Federation of Electric Power Companies of Japan)
"Annual Securities Report," "Hand Book of Electric Power Industry"

3. Organization Chart

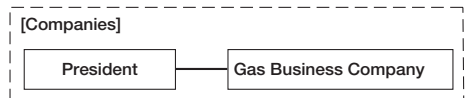
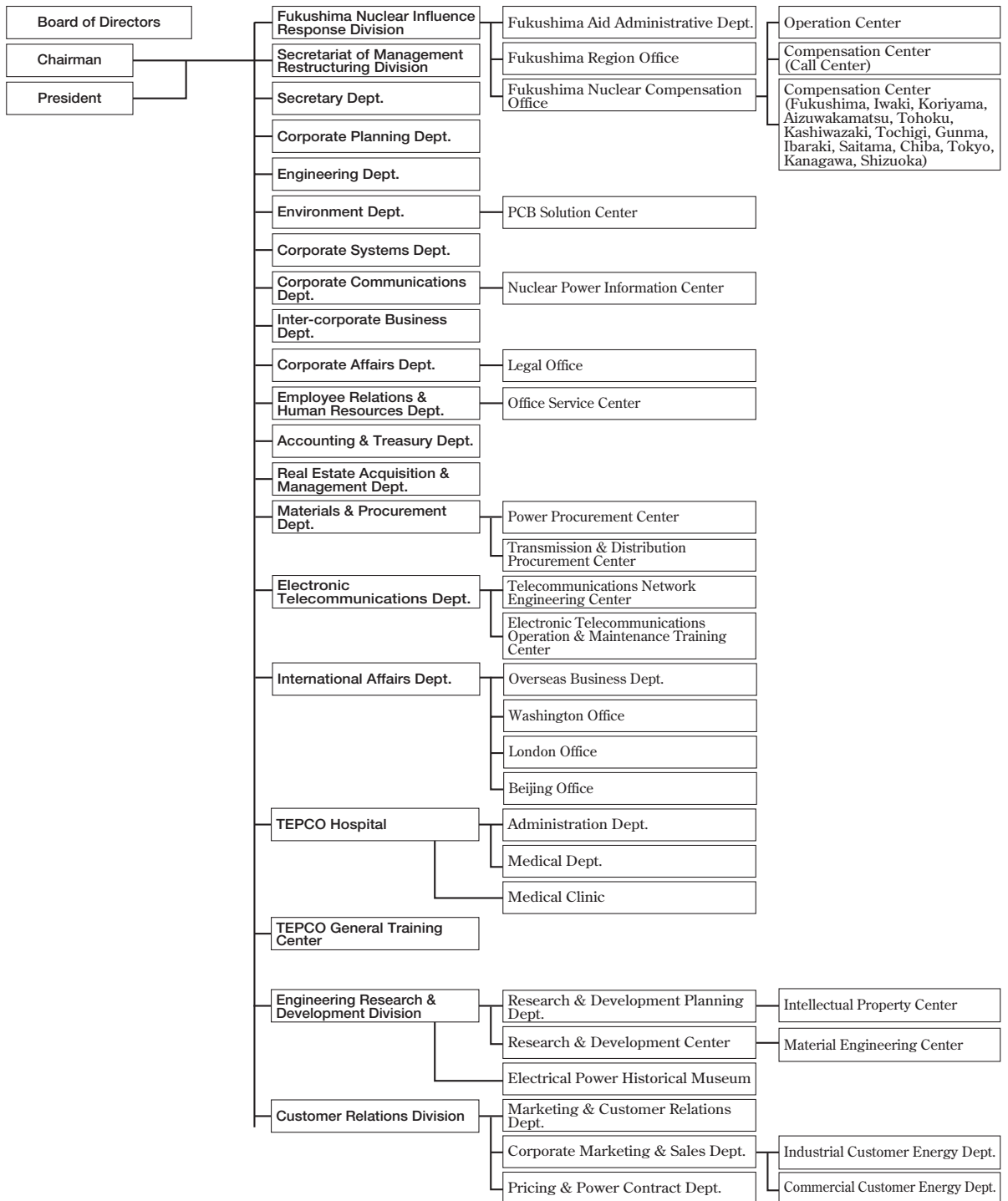

(as of July 1, 2012)

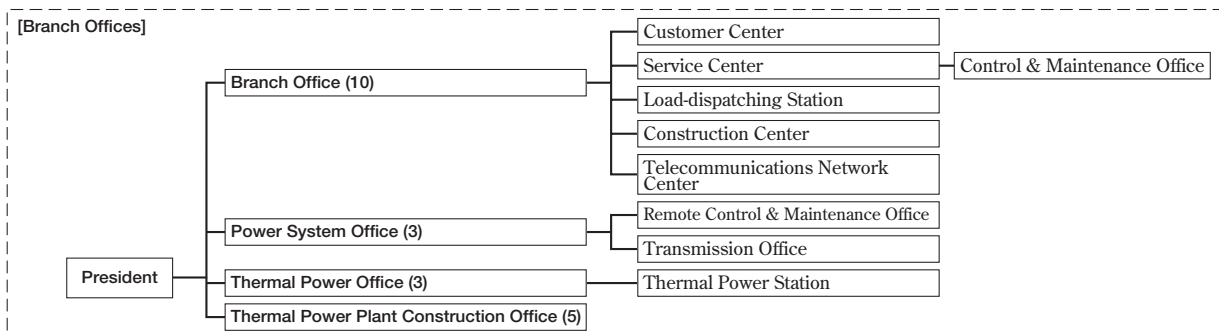
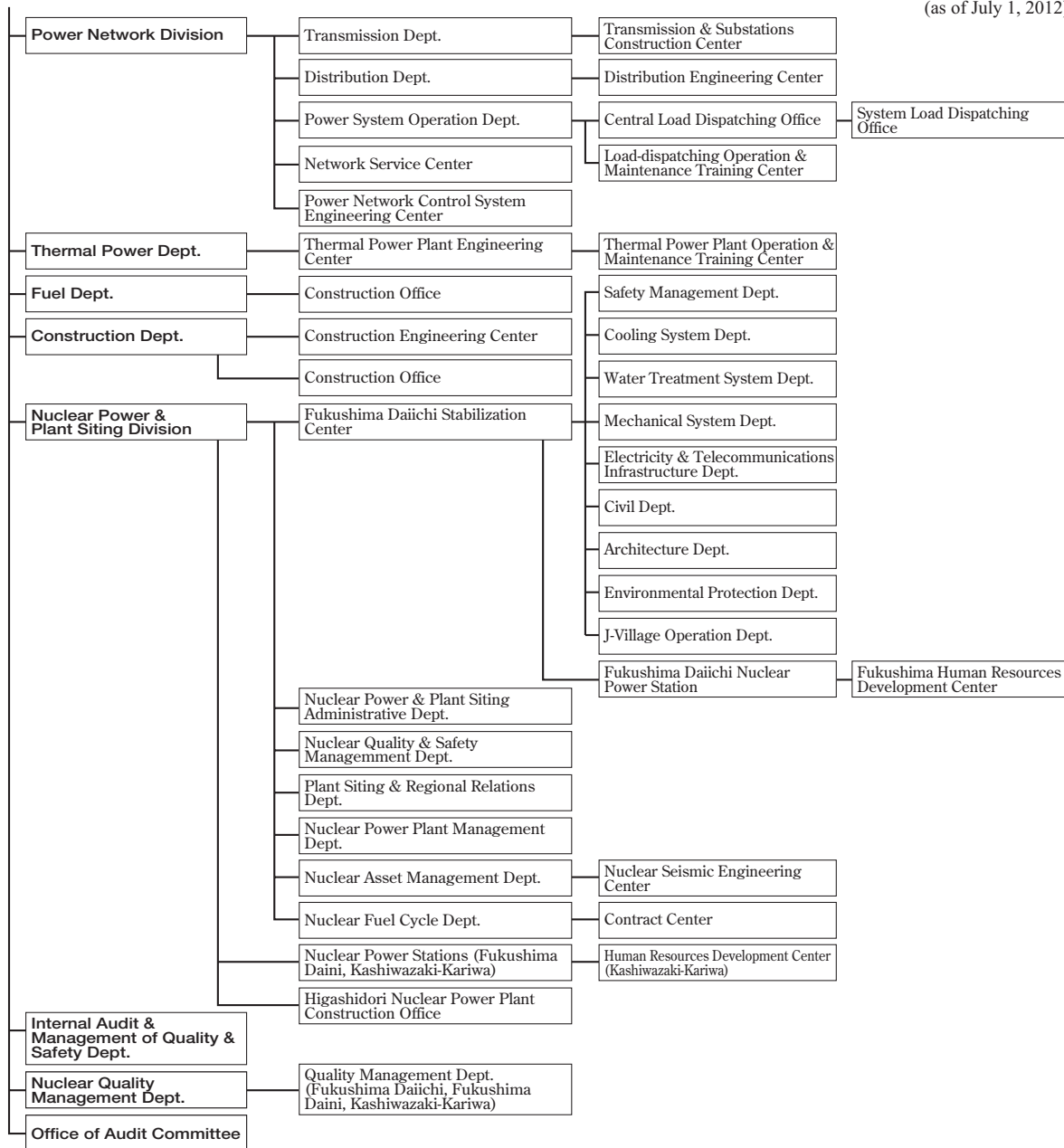

III. Power Demand

1. Changes in Japan's GDP and TEPCO's Power Demand

(1) Changes in Japan's GDP and TEPCO's Power Demand

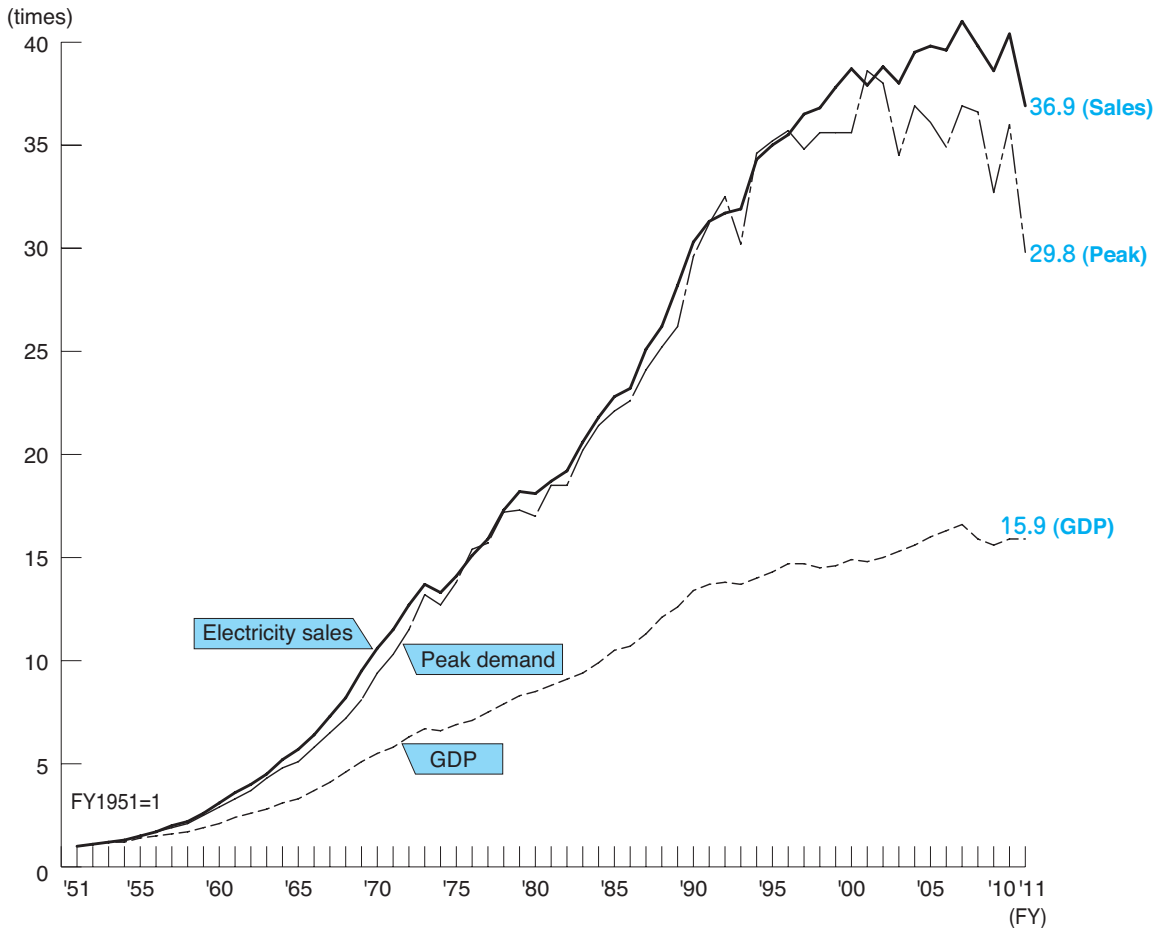

Note: Real GDP is based on the 2005 price standard (continuity system). However, years before 1993 are estimated based on the 2000 price standard (continuity system), years before 1979 are estimated based on the 1990 price standard (fixed benchmark year), and years before 1955 are estimated based on the real GDP (source: "Handbook of Energy & Economic Statistics in Japan," EDMC).

(2) Average Rates of Increase in GDP, Final Energy Consumption, Electricity Sales, and Peak Demand

(%)

Period (FY)	1951 - 2011 (60 years)	1963 - 1973 (10 years)	1973 - 1979 (6 years)	1979 - 1985 (6 years)	1985 - 1990 (5 years)	1990 - 1997 (7 years)	1997 - 2007 (10 years)	2007 - 2011 (4 years)
GDP (A)	4.7	8.9	3.7	4.0	5.0	1.4	1.1	-0.7
TEPCO Electricity Sales (B)	6.2	11.7	4.9	3.8	5.9	2.7	1.1	-2.5
Final Energy Consumption (C)	4.0 (^{'53-'11})	11.6	0.9	-0.5	4.2	1.8	0.1	-1.8 (^{'07-'10})
GDP Elasticity (B/A)	1.3	1.3	1.3	0.9	1.2	2.0	1.1	-
GDP Elasticity (C/A)	0.9 (^{'53-'11})	1.3	0.2	-	0.8	1.3	0.1	-
Peak Demand	5.8	11.9	4.7	4.1	6.0	2.3	0.6	-5.2

- Notes:
1. FY1973 was the year when the first oil crisis occurred.
 2. FY1979 was the year when the second oil crisis occurred.
 3. FY1985 was the year when the economic recession caused by "strong yen" occurred.
 4. FY1990 was the year when the "bubble" economy collapsed.
 5. FY2007 and 2008 were the years when the worldwide recession occurred.
 6. The final energy consumption is quoted from "General energy statistics," Agency for Natural Resources and Energy.

(3) Recent Changes in GDP Elasticity

(%)

FY	1991	1992	1993	1994	1995	1996	1997	1998	1999	2000	2001	2002	2003	2004	2005	2006	2007	2008	2009	2010	2011
GDP (A) (% change from the previous year)	2.3	0.7	-0.5	1.5	2.7	2.7	0.1	-1.5	0.5	2.0	-0.4	1.1	2.3	1.5	1.9	1.8	1.8	-3.7	-2.0	3.2	-0.0
TEPCO Electricity Sales (B) (% change from the previous year)	3.5	1.1	0.7	7.4	2.2	1.2	3.1	0.6	2.7	2.3	-1.8	2.3	-2.1	3.9	0.7	-0.4	3.4	-2.8	-3.0	4.7	-8.6
Final Energy Consumption (C) (% change from the previous year)	1.5	0.8	1.0	3.4	3.3	1.6	0.9	-1.7	2.5	1.0	-1.2	1.4	-0.8	1.1	-0.3	-0.2	-1.1	-6.8	-2.2	4.0	-
GDP Elasticity (B/A)	1.5	1.5	-	5.0	0.8	0.5	21.0	-	5.0	1.2	-	2.1	-	2.7	0.4	-	1.9	-	-	1.5	-
GDP Elasticity (C/A)	0.6	1.1	-	2.3	1.3	0.6	-	-	4.6	0.5	-	1.3	-	0.7	-	-	-	-	-	1.3	-
Peak Demand (% change from the previous year)	5.3	4.2	-7.2	14.7	1.8	1.3	-2.4	2.1	0.1	-0.0	8.5	-1.7	-9.2	7.2	-2.2	-3.4	5.9	-0.9	-10.5	10.1	-17.2

Note: Peak demand: Daily peak at generation end

(4) Electric Curve of Large Industrial Power as Diffusion Index

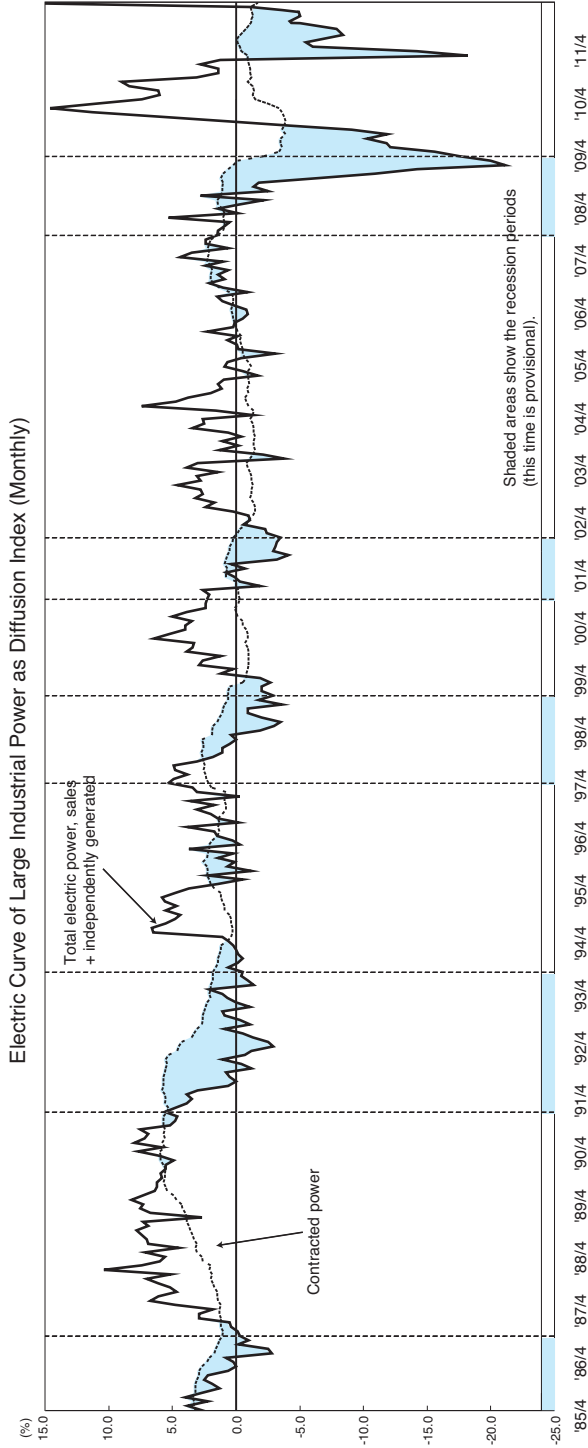

Growth Rate (%)	FY2003				FY2004				FY2005				FY2006				FY2007				FY2008				FY2009				FY2010				FY2011			
	Q1	Q2	Q3	Q4	Q1	Q2	Q3	Q4	Q1	Q2	Q3	Q4	Q1	Q2	Q3	Q4	Q1	Q2	Q3	Q4	Q1	Q2	Q3	Q4	Q1	Q2	Q3	Q4	Q1	Q2	Q3	Q4				
(a) Total electric power, sales + independently generated	2.7	-1.7	0.1	2.1	0.9	5.3	1.5	-0.4	0.4	-1.2	0.9	-0.1	-0.5	0.6	1.3	1.5	3.0	1.8	1.3	1.8	-0.4	-0.3	-8.3	-8.3	-18.5	-15.0	-11.3	-4.4	10.6	8.2	7.2	1.5	-5.4	-8.5	-7.8	5.0
(b) Contracted power	-0.9	-1.3	-1.4	-1.4	-1.2	-0.8	-1.0	-0.9	-1.0	-0.5	-0.3	0.1	0.3	0.3	1.7	2.0	2.2	2.1	1.1	1.0	1.3	1.1	1.1	0.3	-3.1	-3.6	-3.8	-3.6	-1.8	-1.2	-1.1	-0.9	-0.3	-0.3	-0.7	-1.5
(a)-(b) Gap of the growth rates above	3.6	-0.4	1.5	3.5	2.1	6.1	2.5	0.5	1.4	-0.7	1.2	-0.2	-0.8	0.3	-0.4	-0.5	0.8	0.8	-0.3	0.2	0.8	-1.7	-1.4	-7.4	-18.6	-11.9	-7.7	-0.6	14.2	10.0	8.4	2.6	-4.5	-8.2	-7.1	-3.5

Note: The electric curve of large industrial power is an indicator for assessing the current state of the economy from the power demand side. It shows the year-to-year growth of the volume of large industrial power (including independent power generation) and large-scale contracted power.

(5) Electrification Rate (primary energy supply base)

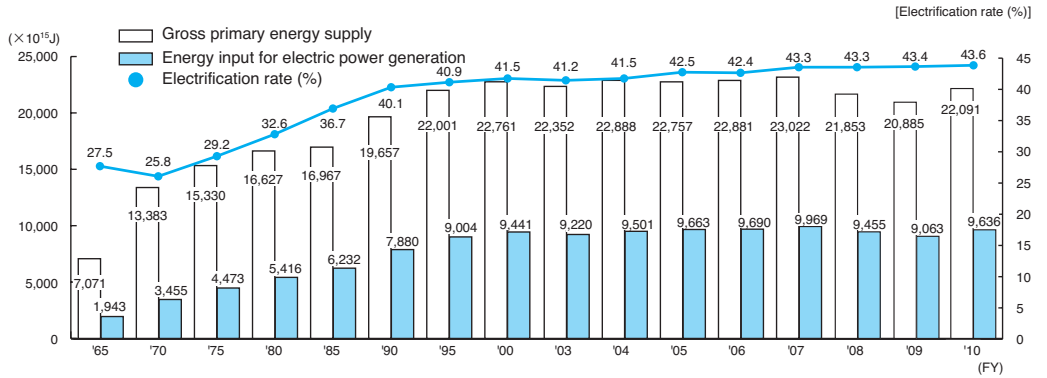

Source: "General Energy Statistics 2010," Agency for Natural Resources and Energy.

2. Electricity Sales

(1) Changes in Electricity Sales and Number of Customers (FY2005 - FY2011)

		FY	2005	2006	2007	2008	2009	2010	2011
Electricity Sales	Other than Specified-Scale Demand	Lighting	95.2	93.2	97.6	96.1	96.1	103.4	95.8
		Power	13.5	12.6	12.8	11.9	11.4	12.2	11.2
	Specified-Scale Demand	180.0	181.8	187.0	181.0	172.7	177.8	161.3	
	Total	288.7	287.6	297.4	289.0	280.2	293.4	268.2	
Number of Customers	Lighting	25.43	25.76	26.05	26.27	26.42	26.58	26.67	
	Power	2.36	2.32	2.28	2.24	2.19	2.16	2.11	
	Total	27.80	28.09	28.34	28.51	28.62	28.73	28.78	
Composition Ratio	Residential Purposes	70	70	70	71	73	72	71	
	Industrial Purposes	30	30	30	29	27	28	29	

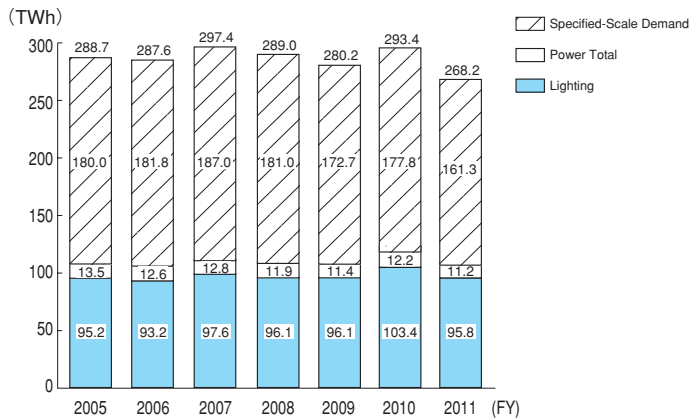

- Notes:
1. Units of electricity sales: 1 TWh
 2. Customer subscriptions at the end of fiscal year, in units of one million. Does not include specified-scale demand.
 3. The scope of specified-scale demand users after FY2005 is in principle customers with a contract of more than 50 kW.

(2) Changes in Electricity Sales and Number of Customers (FY2000 - FY2004)

		FY	2000	2001	2002	2003	2004
Electricity Sales	Other than Specified-Scale Demand	Lighting	86.0	85.1	89.4	86.9	92.6
		Commercial Power	58.0	58.3	59.8	59.3	44.4
		Small Industrial Power	32.6	31.1	30.8	29.9	31.1
		High-Voltage (B)	23.3	22.8	23.0	22.7	-
		Other Power Services	3.2	3.1	3.0	2.9	2.7
		Power Total	117.1	115.3	116.6	114.8	78.2
	Specified-Scale Demand	77.6	75.1	76.0	74.3	115.9	
	Total	280.7	275.5	281.9	276.0	286.7	
Number of Customers	Lighting	23.88	24.23	24.54	24.82	25.12	
	Power	2.79	2.76	2.71	2.68	2.63	
	Total	26.67	26.99	27.25	27.50	27.74	
Composition Ratio	Residential Purposes	69	70	70	70	70	
	Industrial Purposes	31	30	30	30	30	

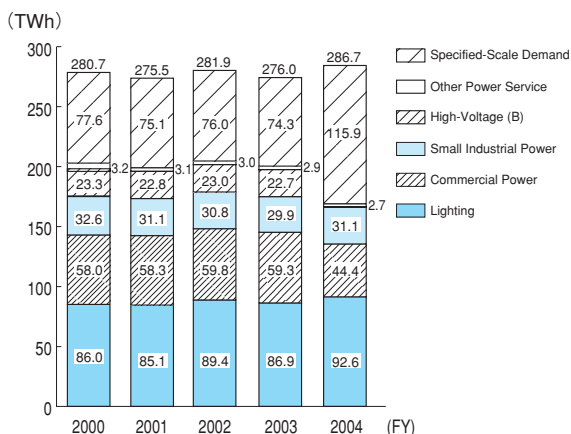

- Notes:
1. Units of electricity sales: 1 TWh
 2. Customer subscriptions at the end of fiscal year, in units of million. Does not include specified-scale demand.
 3. For the years FY2000 - FY2003, the specified-scale demand as a rule includes customers with a contract of at least 2MW. For FY2004, the specified-scale demand as a rule includes customers with a contract of at least 500 kW.
 4. The composition ratio represents the ratio to electricity sales (%): residential purposes indicates public and other uses (railways, etc.) under Lighting, Night-Only Service, Commercial power, Low-voltage power; and the remainder is for industrial purposes.
 5. Totals in the table may not agree with the sums of each column because of being rounded off.
 6. The format was modified since year 2000 when extra high voltage power sector was newly set due to deregulation of electricity.

(3) Changes in Electricity Sales and Number of Customers (until FY1999)

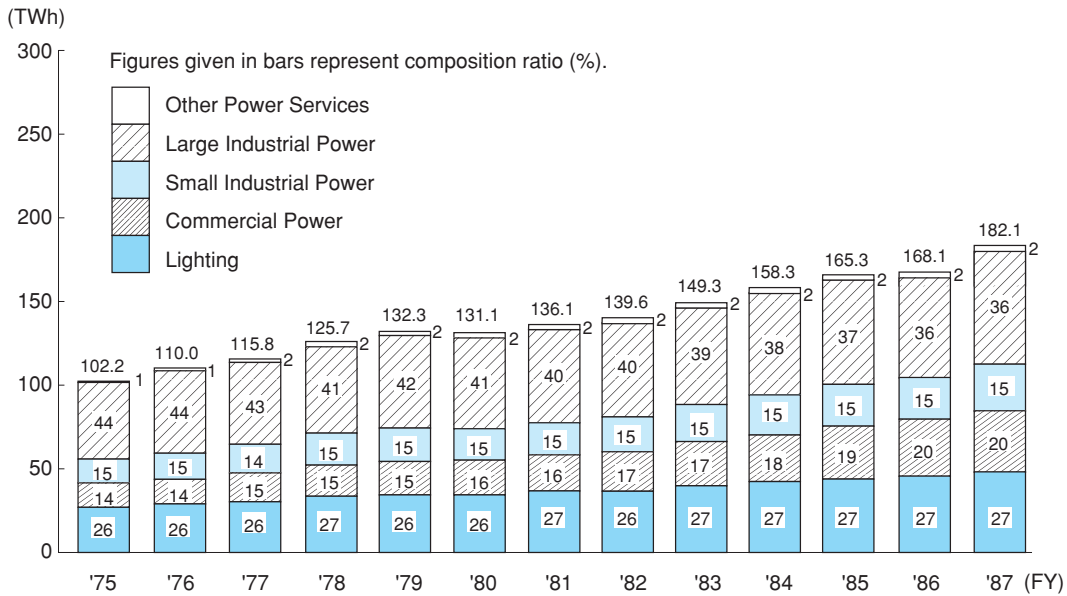

		FY	1975	1976	1977	1978	1979	1980	1981	1982	1983	1984	1985	1986	1987	
Electricity Sales	Lighting		27.0	28.5	30.2	33.3	34.4	34.3	35.9	37.0	39.9	42.1	44.1	45.3	49.3	
	Commercial Power	Commercial Power	14.4	15.5	17.1	19.4	20.4	20.6	22.2	23.6	26.1	28.6	31.0	33.0	36.8	
		Low-Voltage	5.3	5.5	5.9	6.8	7.0	6.6	7.0	7.0	7.7	8.3	8.6	8.5	9.4	
		High-Voltage	9.6	10.4	11.0	11.9	12.5	12.6	13.1	13.4	14.5	15.6	16.3	16.6	18.0	
	Total	14.9	15.9	16.9	18.7	19.5	19.2	20.1	20.4	22.2	23.9	24.9	25.1	27.4		
	Large Industrial Power	General	34.6	35.9	36.0	37.6	39.7	39.4	39.8	40.2	43.1	43.1	45.5	46.6	47.0	49.9
		Load Adjustment Contracts	10.0	12.6	13.4	14.2	15.6	14.6	14.9	15.1	14.5	14.5	15.1	14.0	14.9	
		Total	44.6	48.5	49.4	51.8	55.3	54.0	54.7	55.3	57.6	60.0	61.7	61.0	64.8	
	Other Power Services	1.3	1.6	2.2	2.5	2.7	3.0	3.2	3.3	3.5	3.7	3.6	3.7	3.7	3.8	
	Power Total	75.2	81.5	85.6	92.4	97.9	96.8	100.2	102.6	109.4	116.2	121.2	122.8	132.8		
Lighting and Power Total	102.2	110.0	115.8	125.7	132.3	131.1	136.1	139.6	149.3	158.3	165.3	168.1	182.1			
Number of Customers	Lighting		13.43	13.91	14.36	14.82	15.27	15.65	16.01	16.36	16.71	17.07	17.45	17.87	18.36	
	Power		1.62	1.75	1.87	1.99	2.12	2.23	2.30	2.36	2.41	2.46	2.50	2.55	2.59	
	Total		15.05	15.66	16.23	16.81	17.39	17.88	18.31	18.72	19.12	19.53	19.95	20.42	20.95	
Composition Ratio	Residential Purposes		53	53	54	55	55	55	56	57	58	58	58	60	60	
	Industrial Purposes		47	47	46	45	45	45	44	43	42	42	42	40	40	

- Notes:
1. Units of electricity sales: 1 TWh
 2. Customer subscriptions at the end of fiscal year, in units of one million.
 3. The composition ratio represents the ratio to electricity sales (%): residential purposes indicates public and other uses (railways, etc.) under Lighting, Night-Only Service, Commercial Power, Low-Voltage Power, Large Industrial Power; and the remainder is for industrial purposes.

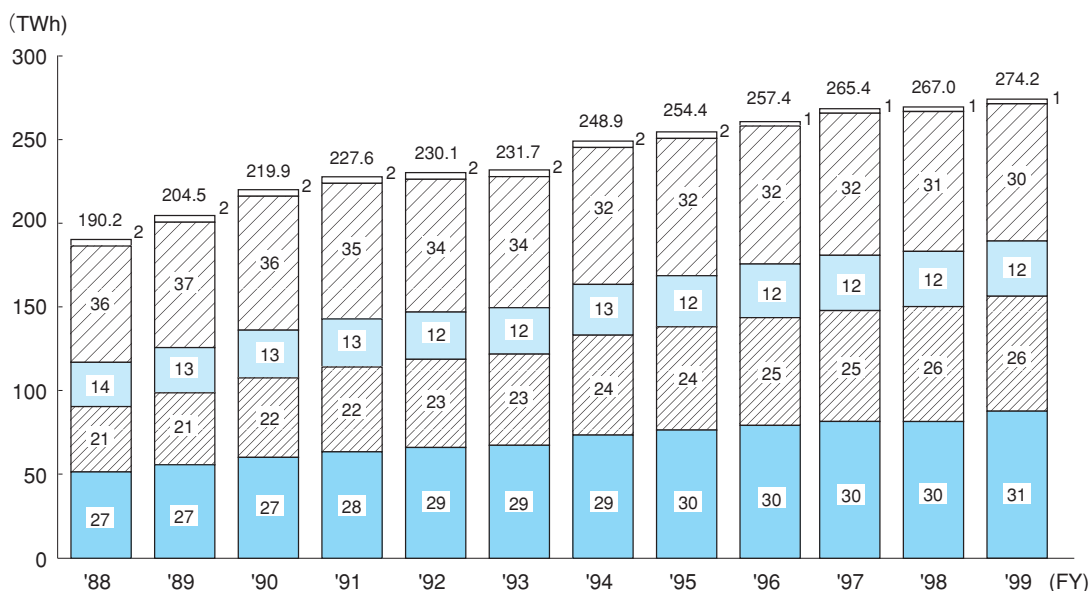

		FY	1988	1989	1990	1991	1992	1993	1994	1995	1996	1997	1998	1999	
Electricity Sales	Power	Lighting	51.5	55.8	60.2	63.5	66.1	67.4	73.5	76.5	76.5	78.9	81.0	84.0	
		Commercial Power	39.0	42.9	47.4	50.6	52.6	54.4	59.6	61.6	63.4	66.7	69.1	71.5	
		Small Industrial Power	Low-Voltage	9.3	10.0	10.9	11.0	10.8	10.6	12.3	12.3	12.0	12.3	12.4	12.9
			High-Voltage	17.1	17.0	17.6	17.7	17.4	17.1	18.0	18.2	18.4	18.9	18.6	19.0
		Total	26.4	27.0	28.5	28.7	28.2	27.7	30.3	30.5	30.4	31.2	31.0	31.9	
		Large Industrial Power	General	54.0	58.6	62.2	63.8	62.9	62.4	65.5	66.1	67.1	68.6	67.3	68.2
			Load Adjustment Contracts	15.3	16.2	17.7	17.1	16.3	15.8	16.2	15.8	15.9	16.4	15.1	15.2
			Total	69.4	74.8	79.9	80.9	79.2	78.2	81.7	81.9	83.0	85.0	82.4	83.4
		Other Power Services	3.9	4.0	3.9	3.9	4.0	4.0	3.8	3.9	4.1	4.1	3.6	3.5	3.4
		Power Total	138.7	148.7	159.7	164.1	164.0	164.3	175.4	177.9	180.9	186.5	186.0	190.2	
Lighting and Power Total		190.2	204.5	219.9	227.6	230.1	231.7	248.9	254.4	257.4	265.4	267.0	274.2		
Number of Customers	Lighting	18.86	19.43	19.98	20.48	20.89	21.24	21.60	22.04	22.49	22.91	23.25	23.56		
	Power	2.65	2.71	2.76	2.80	2.82	2.83	2.84	2.84	2.84	2.83	2.82	2.80		
	Total	21.51	22.14	22.74	23.28	23.71	24.07	24.44	24.88	25.33	25.74	26.07	26.36		
Composition Ratio	Residential Purposes	60	61	61	62	64	65	66	66	66	67	68	69		
	Industrial Purposes	40	39	39	38	36	35	34	34	34	33	32	31		

(4) Changes in Percentage Composition of Large Industrial Power Customers by Industry Type

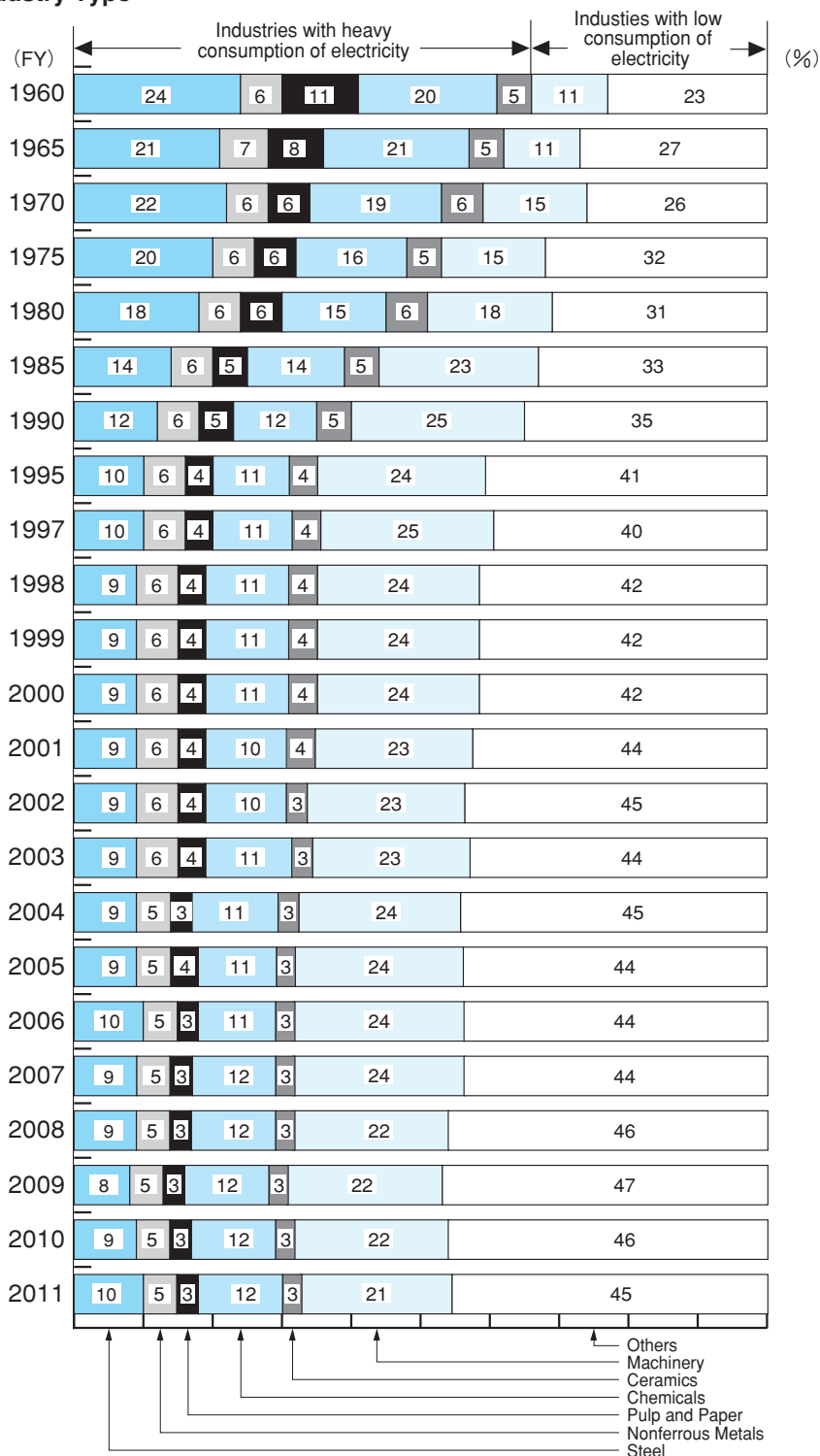

Note: Others include railways, foodstuffs, metals, oil and coal, plastics, printing, publishing, water service, and other.

(5) Residential Customer Power Demand

Changes in Energy Consumption and Contract Power per Household
(Monthly average in the TEPCO service area)

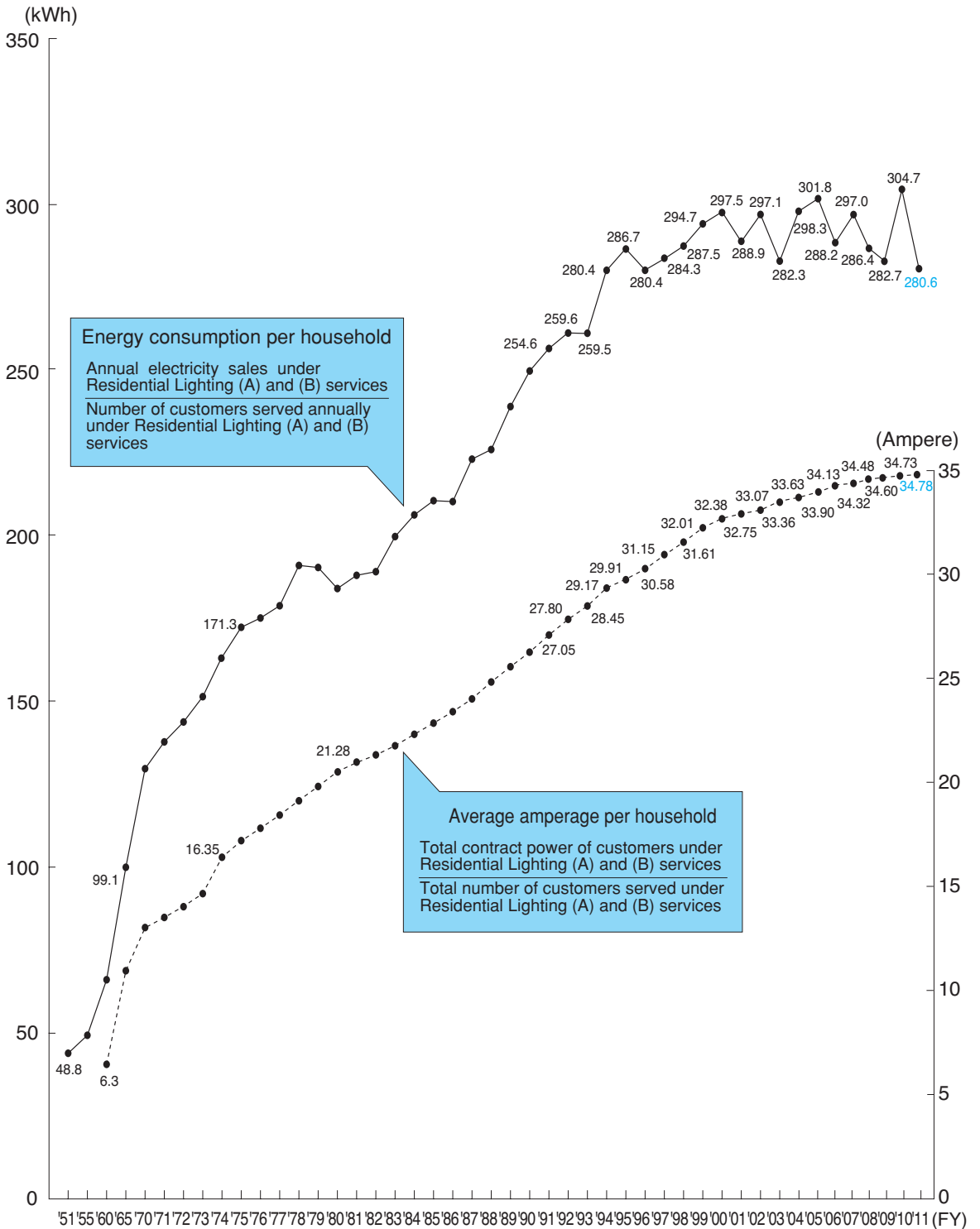

3. Peak Demand

(1) Changes in Peak Demand (daily peak at generation end)

FY	Winter			Summer			Electricity Demand per Day		
	System Peak Load (GW)	Date	Change from Previous Year (GW)	Peak Load (GW)	Date	Change from Previous Year (GW)	Maximum Demand per Day (GWh)	Date	Change from Previous Year (GWh)
1951	1.665	Mar. 31, 1952 (Mon)	-	1.567	May 16, 1951 (Wed)	-	31.0	May 8, 1951 (Tue)	-
1955	2.572	Dec. 21, 1955 (Wed)	0.348	2.284	Sep. 28, 1955 (Wed)	0.276	43.7	Dec. 21, 1955 (Wed)	4.8
1956	2.840	Dec. 11, 1956 (Tue)	0.268	2.486	Sep. 26, 1956 (Wed)	0.202	46.9	Feb. 7, 1957 (Thu)	3.2
1957	3.204	Dec. 20, 1957 (Fri)	0.364	2.711	Sep. 16, 1957 (Mon)	0.225	52.9	Dec. 5, 1957 (Thu)	6.0
1958	3.537	Jan. 13, 1959 (Tue)	0.333	2.990	Sep. 25, 1958 (Thu)	0.279	60.9	Dec. 26, 1958 (Fri)	8.0
1959	4.207	Jan. 19, 1960 (Tue)	0.670	3.589	Sep. 25, 1959 (Fri)	0.599	71.7	Mar. 26, 1960 (Sat)	10.8
1960	4.764	Jan. 13, 1961 (Fri)	0.557	4.043	Sep. 20, 1960 (Tue)	0.454	82.0	Dec. 22, 1960 (Thu)	10.3
1961	5.547	Jan. 23, 1962 (Tue)	0.783	4.690	Jun. 28, 1961 (Wed)	0.647	96.3	Mar. 30, 1962 (Fri)	14.3
1962	6.111	Jan. 24, 1963 (Thu)	0.564	5.290	Aug. 22, 1962 (Wed)	0.600	108.0	Mar. 12, 1963 (Tue)	11.7
1963	7.157	Jan. 24, 1964 (Fri)	1.046	6.198	Aug. 23, 1963 (Fri)	0.908	124.5	Jan. 31, 1964 (Fri)	16.5
1964	8.059	Dec. 17, 1964 (Thu)	0.902	7.190	Aug. 26, 1964 (Wed)	0.992	141.3	Dec. 17, 1964 (Thu)	16.8
1965	8.422	Jan. 21, 1966 (Fri)	0.363	7.989	Aug. 25, 1965 (Wed)	0.799	151.4	Jan. 25, 1966 (Tue)	10.1
1966	9.575	Dec. 13, 1966 (Tue)	1.153	9.069	Aug. 24, 1966 (Wed)	1.080	172.0	Feb. 9, 1967 (Thu)	20.6
1967	10.874	Dec. 14, 1967 (Thu)	1.299	10.477	Aug. 25, 1967 (Fri)	1.408	193.9	Dec. 19, 1967 (Thu)	21.9
1968	11.913	Jan. 29, 1969 (Wed)	1.039	11.805	Aug. 9, 1968 (Fri)	1.328	218.7	Feb. 21, 1969 (Fri)	24.8
1969	13.424	Mar. 4, 1970 (Wed)	1.511	13.569	Aug. 8, 1969 (Fri)	1.764	250.9	Feb. 26, 1970 (Thu)	32.2
1970	14.791	Dec. 25, 1970 (Fri)	1.367	15.690	Sep. 3, 1970 (Thu)	2.121	283.7	Sep. 3, 1970 (Thu)	32.8
1971	16.032	Feb. 10, 1972 (Thu)	1.241	17.165	Aug. 11, 1971 (Wed)	1.475	303.7	Aug. 11, 1971 (Wed)	20.0
1972	17.598	Dec. 19, 1972 (Tue)	1.566	19.083	Sep. 8, 1972 (Fri)	1.918	334.7	Sep. 7, 1972 (Wed)	31.0
1973	18.169	Nov. 6, 1973 (Tue)	0.571	21.958	Aug. 9, 1973 (Thu)	2.875	386.1	Aug. 10, 1973 (Fri)	51.4
1974	18.894	Dec. 10, 1974 (Tue)	0.725	21.177	Aug. 29, 1974 (Thu)	-0.781	361.8	Aug. 29, 1974 (Thu)	-24.3
1975	20.175	Dec. 9, 1975 (Tue)	1.281	23.041	Aug. 21, 1975 (Thu)	1.864	391.3	Jul. 31, 1975 (Thu)	29.5
1976	21.307	Feb. 10, 1977 (Thu)	1.132	25.562	Aug. 24, 1976 (Tue)	2.521	433.0	Aug. 24, 1976 (Tue)	41.7
1977	22.006	Jan. 26, 1978 (Thu)	0.699	26.119	Aug. 5, 1977 (Fri)	0.557	453.7	Aug. 5, 1977 (Fri)	20.7
1978	24.136	Dec. 19, 1978 (Thu)	2.130	28.566	Jul. 25, 1978 (Tue)	2.447	498.1	Jul. 25, 1978 (Tue)	44.4
1979	24.423	Feb. 19, 1980 (Tue)	0.287	28.850	Jul. 24, 1979 (Tue)	0.284	505.8	Jul. 24, 1979 (Tue)	7.7
1980	25.298	Dec. 23, 1980 (Tue)	0.875	28.313	Jul. 22, 1980 (Tue)	-0.537	499.8	Jul. 23, 1980 (Wed)	-6.0
1981	25.920	Jan. 18, 1982 (Mon)	0.622	30.868	Jul. 17, 1981 (Fri)	2.555	541.6	Jul. 17, 1981 (Fri)	41.8
1982	27.341	Jan. 18, 1983 (Tue)	1.421	30.783	Aug. 24, 1982 (Tue)	-0.085	537.3	Aug. 24, 1982 (Tue)	-4.3
1983	28.862	Feb. 17, 1984 (Fri)	1.521	33.633	Aug. 19, 1983 (Fri)	2.850	591.1	Sep. 6, 1983 (Tue)	53.8
1984	30.137	Jan. 24, 1985 (Thu)	1.275	35.700	Sep. 3, 1984 (Mon)	2.067	627.5	Aug. 7, 1984 (Tue)	36.4
1985	31.861	Feb. 18, 1986 (Tue)	1.724	36.780	Aug. 29, 1985 (Thu)	1.080	643.7	Aug. 29, 1985 (Thu)	16.2
1986	32.946	Jan. 12, 1987 (Mon)	1.085	37.650	Sep. 4, 1986 (Thu)	0.870	659.4	Sep. 4, 1986 (Thu)	15.7
1987	34.906	Dec. 7, 1987 (Mon)	1.960	40.120	Aug. 21, 1987 (Fri)	2.470	717.0	Jul. 24, 1987 (Fri)	57.6
1988	38.010	Jan. 23, 1989 (Mon)	3.104	42.020	Aug. 23, 1988 (Tue)	1.900	756.8	Aug. 22, 1988 (Mon)	39.8
1989	40.350	Jan. 23, 1990 (Tue)	2.340	43.700	Aug. 22, 1989 (Tue)	1.680	781.9	Sep. 12, 1989 (Tue)	25.1
1990	42.200	Jan. 21, 1991 (Mon)	1.850	49.300	Aug. 23, 1990 (Thu)	5.600	902.2	Aug. 24, 1990 (Fri)	120.3
1991	43.500	Mar. 18, 1992 (Wed)	1.300	51.900	Jul. 24, 1991 (Wed)	2.600	919.8	Jul. 24, 1991 (Wed)	17.6
1992	45.200	Jan. 25, 1993 (Mon)	1.700	54.100	Sep. 4, 1992 (Fri)	2.200	960.9	Sep. 3, 1992 (Thu)	41.1
1993	46.150	Feb. 1, 1994 (Tue)	0.950	50.200	Aug. 24, 1993 (Tue)	-3.900	885.3	Aug. 25, 1993 (Wed)	-75.6
1994	45.869	Dec. 20, 1994 (Tue)	-0.281	57.600	Aug. 4, 1994 (Thu)	7.400	1,043.8	Aug. 4, 1994 (Thu)	158.5
1995	47.950	Feb. 2, 1996 (Fri)	2.081	58.650	Aug. 25, 1995 (Fri)	1.050	1,045.9	Aug. 25, 1995 (Fri)	2.1
1996	48.550	Feb. 3, 1997 (Mon)	0.600	59.400	Jul. 18, 1996 (Thu)	0.750	1,077.5	Jul. 18, 1996 (Thu)	31.6
1997	52.300	Jan. 12, 1998 (Mon)	3.750	57.956	Jul. 4, 1997 (Fri)	-1.444	1,053.7	Jul. 8, 1997 (Tue)	-23.8
1998	49.192	Dec. 3, 1998 (Thu)	-3.108	59.200	Jul. 3, 1998 (Fri)	1.244	1,070.5	Jul. 3, 1998 (Fri)	16.8
1999	50.050	Jan. 12, 2000 (Wed)	0.858	59.250	Sep. 1, 1999 (Wed)	0.050	1,069.1	Sep. 14, 1999 (Tue)	-1.4
2000	51.295	Jan. 15, 2001 (Mon)	1.245	59.240	Aug. 3, 2000 (Thu)	-0.010	1,091.8	Aug. 3, 2000 (Thu)	22.7
2001	50.380	Dec. 21, 2001 (Fri)	-0.915	64.300	Jul. 24, 2001 (Tue)	5.060	1,184.3	Jul. 24, 2001 (Tue)	92.5
2002	52.200	Dec. 9, 2002 (Mon)	1.820	63.200	Aug. 1, 2002 (Thu)	-1.100	1,167.6	Aug. 1, 2002 (Thu)	-16.7
2003	49.676	Jan. 19, 2004 (Mon)	-2.524	57.360	Sep. 11, 2003 (Thu)	-5.840	1,073.7	Sep. 12, 2003 (Fri)	-93.9
2004	51.858	Mar. 4, 2005 (Fri)	2.182	61.499	Jul. 20, 2004 (Tue)	4.139	1,155.5	Jul. 21, 2004 (Wed)	81.8
2005	52.360	Feb. 6, 2006 (Mon)	0.502	60.118	Aug. 5, 2005 (Fri)	-1.381	1,134.6	Aug. 5, 2005 (Fri)	-20.9
2006	50.275	Jan. 17, 2007 (Wed)	-2.085	58.058	Jul. 14, 2006 (Fri)	-2.060	1,099.6	Jul. 14, 2006 (Fri)	-35.0
2007	55.022	Jan. 23, 2008 (Wed)	4.747	61.471	Aug. 22, 2007 (Wed)	3.413	1,164.2	Aug. 22, 2007 (Wed)	64.6
2008	50.291	Jan. 9, 2009 (Fri)	-4.731	60.891	Aug. 8, 2008 (Fri)	-0.580	1,157.6	Aug. 8, 2008 (Fri)	-6.6
2009	52.401	Jan. 12, 2010 (Tue)	2.110	54.496	Jul. 30, 2009 (Thu)	-6.395	1,051.9	Feb. 17, 2010 (Wed)	-105.7
2010	51.504	Feb. 14, 2011 (Mon)	-0.897	59.988	Jul. 23, 2010 (Fri)	5.492	1,141.8	Jul. 23, 2010 (Fri)	89.9
2011	49.657	Jan. 20, 2012 (Fri)	-1.847	49.216	Aug. 18, 2011 (Thu)	-10.772	1,013.4	Jan. 20, 2012 (Fri)	-128.4

Note: in the above table indicates the highest figure historically.

<Reference> Recent Changes in Peak Demand

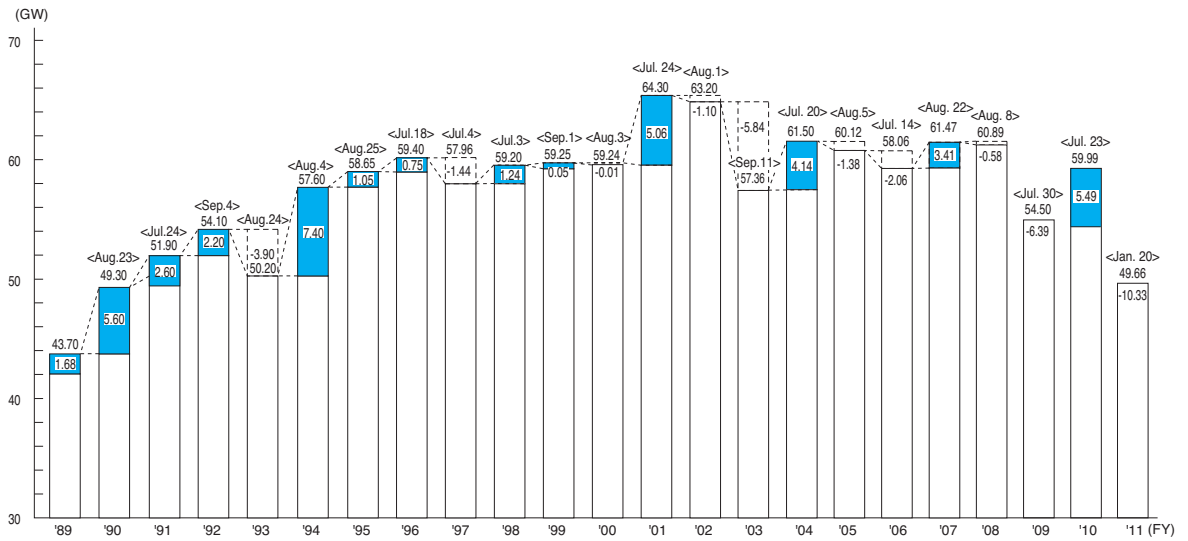

Note: in the above table represents an increase over the previous year.

<Reference> Peak Demand in Major Countries

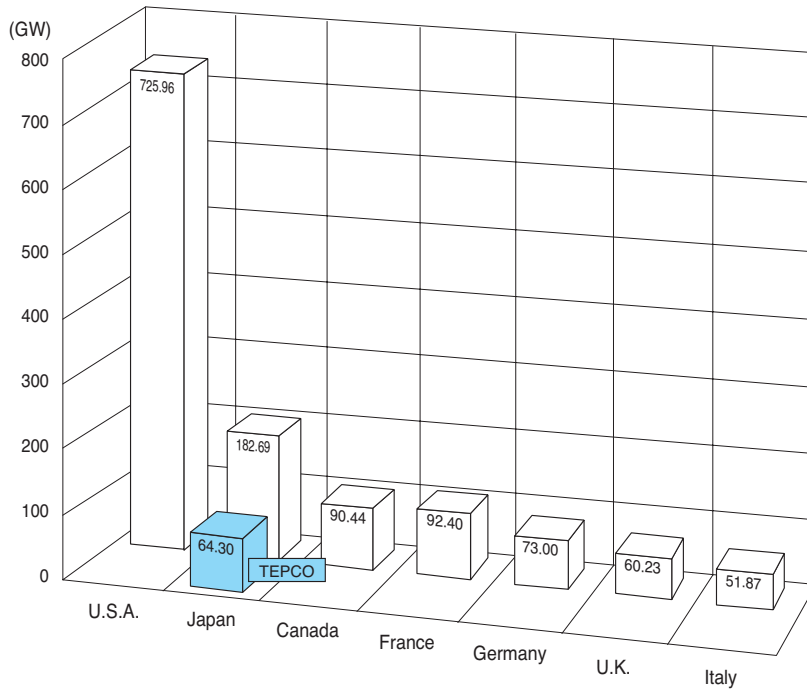

Note: 2009 results. The figure for Japan shows the peak daily output for the 10 major electric power companies (July 24, 2001) together with the peak daily output for TEPCO (July 24, 2001). The figure for U.S.A. is a total of peak demands in the summer of 2009.

Sources: "Overseas Electric Power Industry Statistics (2011)," Japan Electric Power Information Center, Inc.

(2) Trend of Monthly Peak Demand (daily peak at generation end)

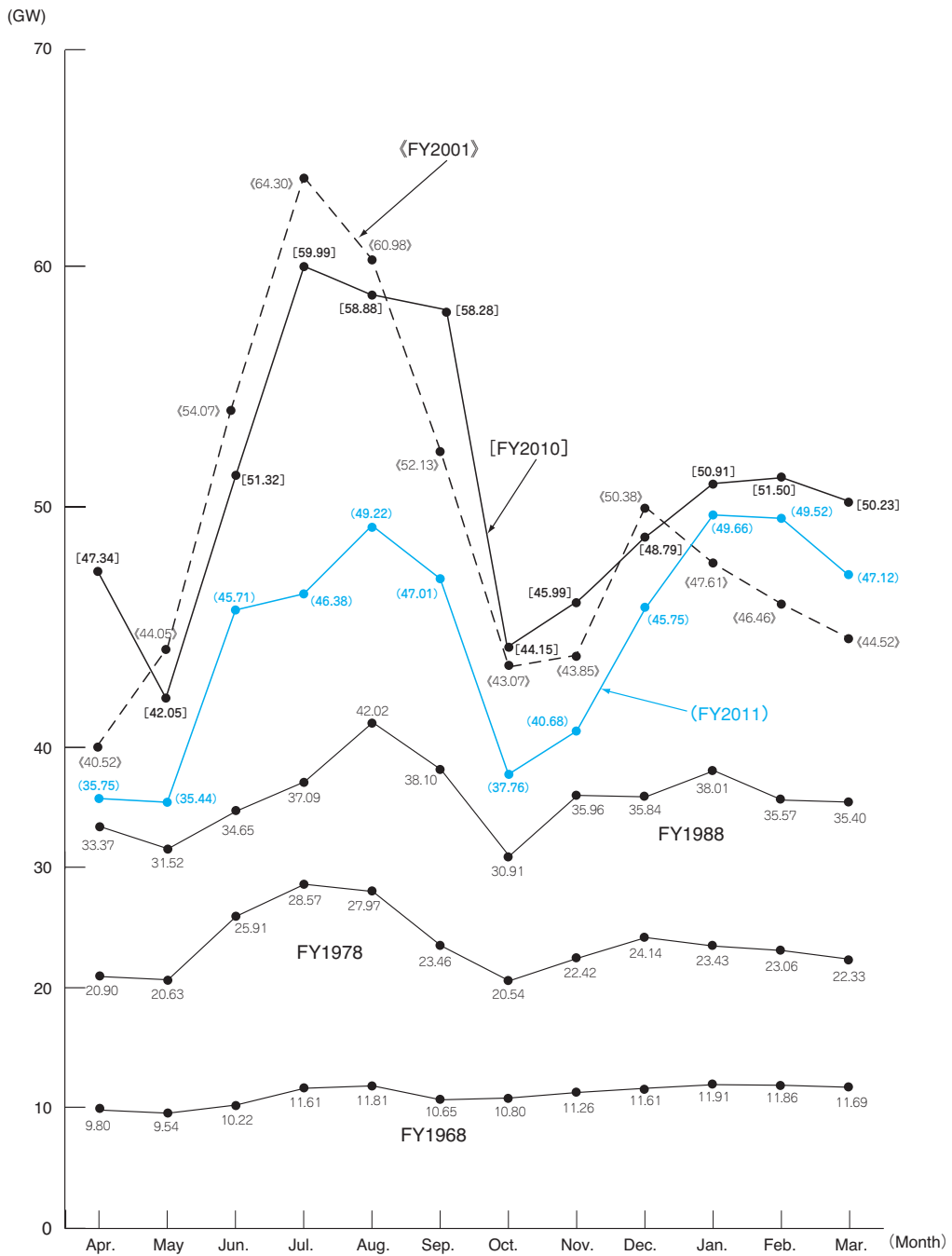

(3) Pattern of Daily Electricity Usage (dates of annual peak demand recorded)

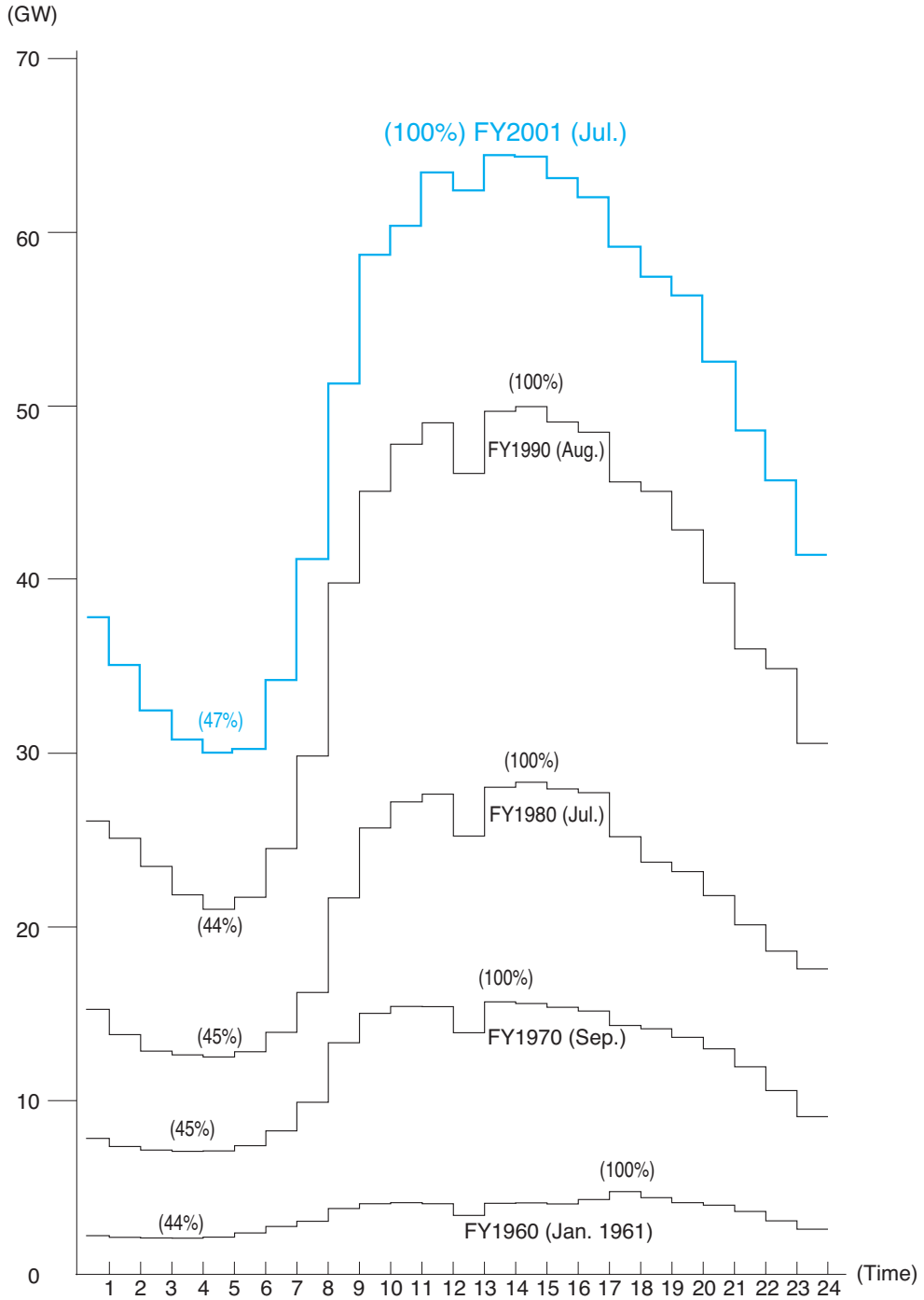

(4) Peak Demand in Summer and Annual Load Factor

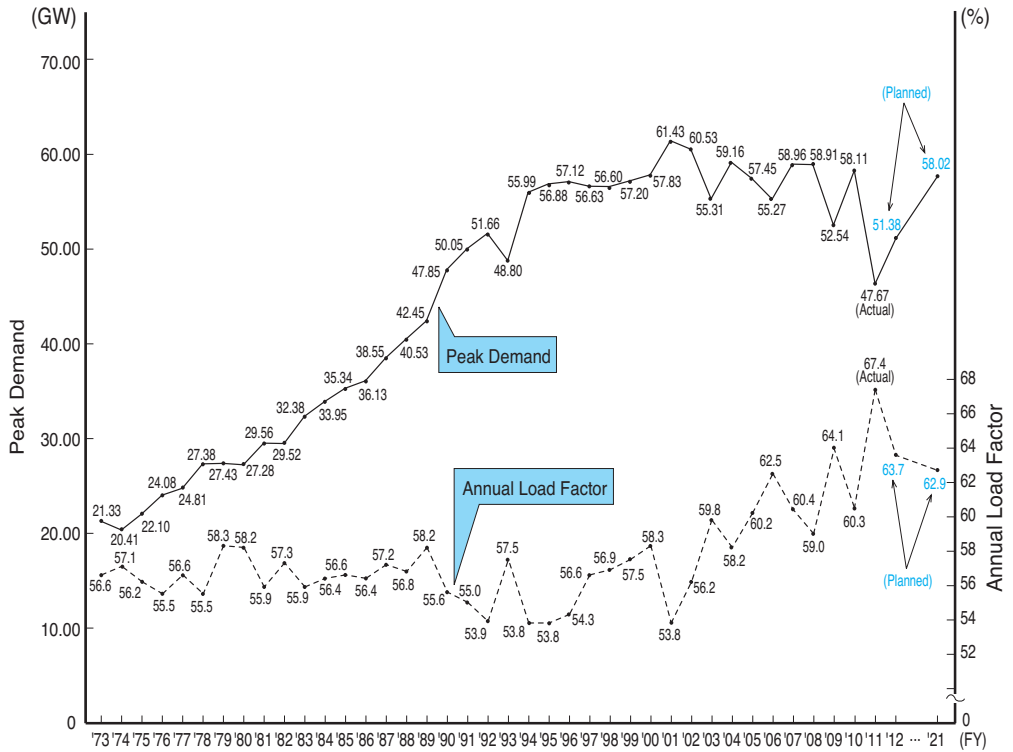

- Note:
1. "Peak demand" here represents the maximum three-day average peak load in Summer at transmission end.
 2. "Planned" values are quoted from Comprehensive Special Business Plan.

IV. Electricity Supply Facilities

1. Power Generation Facilities

(1) Power Generation (authorized capacity)

(Unit: GW)

At the End of FY	May 1, 1951 (established)	1955	1965	1975	1985	1995	2000	2002	2003	2004	2005	2006	2007	2008	2009	2010	2011	Total of 10 EP Co. 2011
Hydro	<242> 1.44 (80.7)	<230> 1.64 (66.8)	<222> 2.10 (25.9)	<185> 3.19 (13.0)	<155> 5.07 (13.5)	<155> 7.63 (14.9)	<160> 8.508 (14.5)	<160> 8.520 (14.1)	<160> 8.520 (13.6)	<160> 8.521 (13.6)	<161> 8.993 (14.5)	<161> 8.993 (14.5)	<160> 8.985 (14.4)	<160> 8.986 (14.0)	<160> 8.987 (13.9)	<162> 8.981 (13.8)	<163> 8.982 (13.5)	<1,183> 35.602 (17.1)
Thermal	< 9 > 0.35 (19.3)	<11> 0.81 (33.0)	<16> 6.00 (74.1)	<26> 19.57 (78.8)	<28> 23.43 (62.3)	<25> 28.98 (56.6)	<24> 33.026 (56.1)	<25> 34.548 (57.2)	<26> 36.831 (58.8)	<26> 36.995 (58.9)	<26> 35.536 (57.5)	<26> 35.533 (57.5)	<26> 36.179 (57.9)	<26> 37.686 (58.9)	<25> 38.189 (59.2)	<25> 38.696 (59.5)	<25> 40.148 (60.4)	<161> 125.483 (60.3)
Nuclear	< - > - (-)	< - > - (-)	< - > - (-)	< 1 > 2.03 (8.2)	< 3 > 9.10 (24.2)	< 3 > 14.60 (28.5)	< 3 > 17.308 (29.4)	< 3 > 17.308 (27.6)	< 3 > 17.308 (27.5)	< 3 > 17.308 (27.5)	< 3 > 17.308 (28.0)	< 3 > 17.308 (28.0)	< 3 > 17.308 (27.7)	< 3 > 17.308 (27.1)	< 3 > 17.308 (26.8)	< 3 > 17.308 (26.6)	< 3 > 17.308* (26.0)	< 15 > 46.343 (22.3)
New Energy etc.	< - > - (-)	< - > - (-)	< - > - (-)	< - > - (-)	< - > - (-)	< - > - (-)	< 1 > 0.001 (0.0)	< 1 > 0.001 (0.0)	< 1 > 0.001 (0.0)	< 1 > 0.001 (0.0)	< 1 > 0.001 (0.0)	< 1 > 0.001 (0.0)	< 1 > 0.001 (0.0)	< 2 > 0.001 (0.0)	< 2 > 0.004 (0.0)	< 2 > 0.004 (0.0)	< 5 > 0.054 (0.1)	< 33 > 0.580 (0.3)
Total	<251> 1.79 (100.0)	<241> 2.44 (100.0)	<238> 8.10 (100.0)	<212> 24.59 (100.0)	<186> 37.59 (100.0)	<183> 51.21 (100.0)	<188> 58.843 (100.0)	<189> 60.377 (100.0)	<190> 62.660 (100.0)	<190> 62.825 (100.0)	<191> 61.837 (100.0)	<191> 61.835 (100.0)	<190> 62.473 (100.0)	<190> 63.981 (100.0)	<190> 64.487 (100.0)	<192> 64.988 (100.0)	<196> 66.472 (100.0)	<1,392> 208.008 (100.0)

- Notes:
- The figures in brackets in the upper rows represent the number of locations or sites. Figures in parentheses in the lower rows represent the percentage composition (%) of authorized capacity.
 - The figures before FY2008 for thermal power include geothermal power.
 - Totals in the table may not agree with the sums of each column because of being rounded off.
 - The figures for new energy etc. consist of wind, photovoltaic and waste power generation before FY2008 (facilities with expected supply capacity and TEPCO's approved facilities). The figures in FY2009 added geothermal and biomass power generation (facilities with expected supply capacity and TEPCO's approved facilities).
 - * On April 19, 2012, following the notification of decommissioning submitted on March 30, 2012 in accordance with Article 9 of the Electric Utilities Industry Law, out of the nuclear plants owned by TEPCO, Units 1-4 (2,812MW) at Fukushima Daiichi Nuclear Power Station were decommissioned. As of the end of March 2012, the output of these units was included.

<Reference> Special Note on Power Generation Facility

- August 18, 1959 Thermal power becomes primary power source, with hydroelectric next
- December 10, 1965 Yagisawa Power Station begins operations (TEPCO's first pumped storage plant)
- March 30, 1968 Generation capacity surpasses 10GW
- April 24, 1970 Minami Yokohama Thermal Power Station begins operations (world's first LNG-only thermal power)
- March 26, 1971 Fukushima Daiichi Nuclear Power Station Unit 1 (460MW) begins operations
- June 16, 1973 End of coal-only thermal power in Japan (Shin-Tokyo Thermal Power Station was the last)
- July 18, 1974 Generation capacity surpasses 20GW
- September 28, 1974 Kashima Thermal Power Station Unit 5 begins operations (first 1,000MW capacity from single unit in Japan)
- October 12, 1978 Fukushima Daiichi Nuclear Power Station Unit 4 begins operations (nuclear power surpasses hydroelectric power)
- October 24, 1979 Fukushima Daiichi Nuclear Power Station Unit 6 (1,100MW) begins operations (Total power station output 4,696MW)
- October 26, 1979 Generation capacity surpasses 30GW
- September 11, 1981 Shin-Takasegawa Power Station completed (maximum output 1,280MW, single-unit output 320MW)
- April 20, 1982 Fukushima Daini Nuclear Power Station Unit 1 (1,100MW) begins operations
- December 17, 1982 Tanbara Power Station Units 1, 4 (300MW each) begin operations
- June 30, 1984 Tsurumi Thermal Power Station (445MW) ceases operations
- February 28, 1985 Yokosuka Thermal Power Station Unit 1 (265MW) begins operations with COM fuel
- September 18, 1985 Kashiwazaki-Kariwa Nuclear Power Station Unit 1 (1,100MW) begins operations

December 20, 1985 Futtsu Thermal Power Station Group 1 Unit 1 (165MW) begins operations
July 4, 1986 Tanbara Power Station Units 2, 3 (300MW x 2) begin operations
November 6, 1986 All units of Futtsu Thermal Power Station Group 1 (1,000MW) begin operations
August 25, 1987 Fukushima Daini Nuclear Power Station Unit 4 (1,100MW) begins operations
Fukushima Daini Nuclear Power Station completed (total output 4,400MW, capacity of nuclear power facilities surpasses 10GW)

September 18, 1987 Higashi Ohgishima Thermal Power Station Unit 1 (1,000MW) begins operations
July 8, 1988 Imaichi Power Station Unit 1 (350MW) begins operations
June 23, 1989 Hirono Thermal Power Station Unit 3 (1,000MW) begins operations
March 12, 1991 Higashi Ohgishima Thermal Power Station Unit 2 (1,000MW) begins operations
August 29, 1991 Shin-Tokyo Thermal Power Station (350MW) ceases operations
December 20, 1991 Imaichi Power Station Units 2, 3 (350MW x 2) begin operations
Imaichi Power Station completed (maximum output 1,050MW, single-unit output 350MW)

January 22, 1993 Hirono Thermal Power Station Unit 4 (1,000MW) begins operations
June 24, 1994 Shiobara Power Station Units 1, 2 (300MW x 2) begin operations
July 7, 1994 Goi Thermal Power Station Unit 6 Gas Turbine (126MW) begins operations
June 16, 1995 Shiobara Power Station Unit 3 (300MW) begins operations
July 2, 1997 Kashiwazaki-Kariwa Nuclear Power Station Unit 7 (1,356MW) begins operations
Kashiwazaki-Kariwa Nuclear Power Station completed (the world's largest nuclear power station with total output of 8,212MW)

January 21, 1998 All units of Yokohama Thermal Power Station Group 7 (1,400MW) begin operations
January 22, 1998 All units of Yokohama Thermal Power Station Group 8 (1,400MW) begin operations
March 25, 1999 Hachijojima Geothermal Power Station (3.3MW) begins operations (TEPCO's first geothermal power station)
March 29, 1999 Chiba Thermal Power Station Units 1 - 4 (600MW) ceases operations
December 3, 1999 Kazunogawa Power Station Unit 1 (400MW) begins operations
March 27, 2000 Yokohama Thermal Power Station Units 1 - 3 (525MW) cease operations
March 31, 2000 Hachijojima Wind Power Station (500kW) begins operations (first commercial wind power plant for a power company)

April 7, 2000 All units of Chiba Thermal Power Station Group 1 (1,440MW) begin operations
June 8, 2000 Kazunogawa Power Station Unit 2 (400MW) begins operations
June 15, 2000 All units of Chiba Thermal Power Station Group 2 (1,440MW) begin operations
August 20, 2003 All units of Shinagawa Thermal Power Station Group 1 (1,140MW) begin operations

November 13, 2003 All units of Futtsu Thermal Power Station Group 3 (1,520MW) begin operations
December 12, 2003 Hitachinaka Thermal Power Station Unit 1 (1,000MW) begins operations
July 12, 2004 Hirono Thermal Power Station Unit 5 (600MW) begins operations
December 20, 2004 Yokosuka Thermal Power Station Unit 1 (265MW) ceases operations
December 20, 2004 Yokohama Thermal Power Station Unit 4 (175MW) ceases operations
December 22, 2005 Kannagawa Hydroelectric Power Station Unit 1 (470MW) begins operations
March 27, 2006 Kawasaki Thermal Power Station Units 1-6 (1,050MW) cease operations
March 27, 2006 Yokosuka Thermal Power Station Unit 2 (265MW) ceases operations
February 5, 2009 All units of Kawasaki Thermal Power Station Group 1 (1500MW) begin operations
October 5, 2010 All units of Futtsu Thermal Power Station Group 4 (1520MW) begins operations
April - September 2011 Urgent installed generation facilities begin operations
Chiba Thermal Power Station (668MW)
Anegasaki Thermal Power Station (5.6MW)
Sodegaura Thermal Power Station (112.2MW)
Yokosuka Thermal Power Station (329.6MW)
Kawasaki Thermal Power Station (128MW)
Ohi Thermal Power Station (209MW)
Hitachinaka Thermal Power Station (253.23MW)

August 10, 2011 Ukishima Photovoltaic Power Station (7MW) begins operations (TEPCO's first Photovoltaic Power Station)

December 19, 2012 Ohgishima Photovoltaic Power Station (13MW) begins operations
January 27, 2012 Komekurayama Photovoltaic Power Station (10MW) begins operations
March 31, 2012 Hitachinaka Thermal Power Station (253.23MW) of Urgent installed generation facilities ceases operations

(2) Generation Capacity by Energy Source

a. Generation Capacity by Energy Source (TEPCO only)

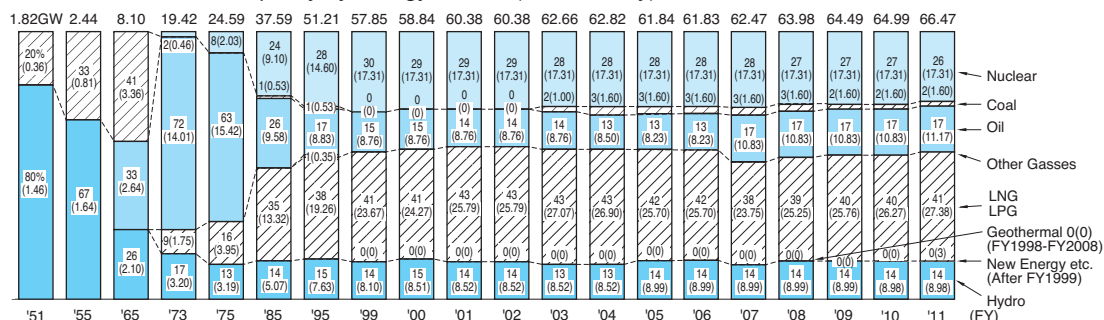

- Notes:
1. Figures at the top and in parentheses are authorized output (GW).
 2. Total capacity for the year may not agree with the sum of each energy source because of being rounded off.
 3. City gas is classified into LNG/LPG after FY1996.
 4. The figures for new energy etc. consist of wind, photovoltaic and waste power generation before FY2008 (facilities with expected supply capacity and TEPCO's approved facilities). The figures added geothermal and biomass power generation after FY2009 (facilities with expected supply capacity and TEPCO's approved facilities).
 5. On April 19, 2012, following the notification of decommissioning submitted on March 30, 2012 in accordance with Article 9 of the Electric Utilities Industry Law, out of the nuclear plants owned by TEPCO, Units 1-4 (2,812MW) at Fukushima Daiichi Nuclear Power Station were decommissioned. As of the end of March 2012, the output of these units was included.

b. Generation Capacity by Energy Source (TEPCO including purchased power)

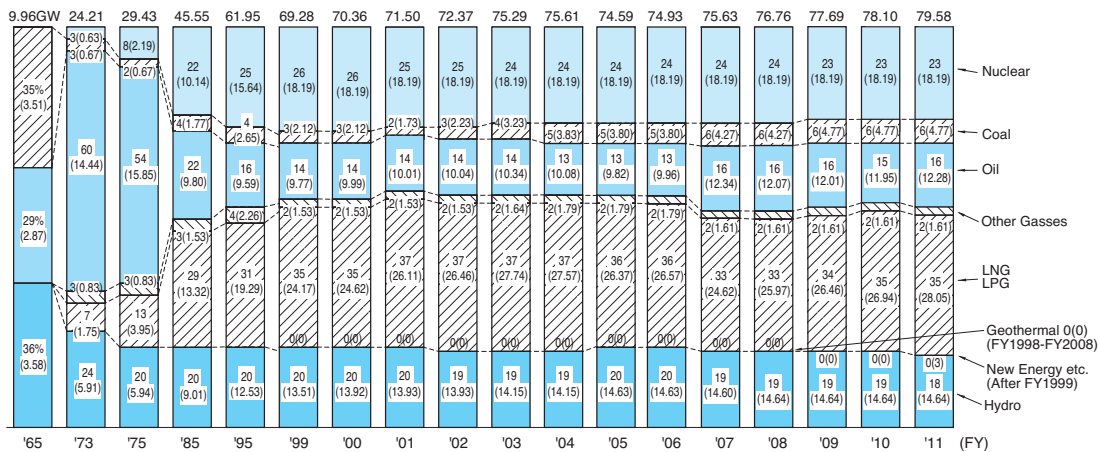

- Notes:
1. Figures at the top and in parentheses are authorized output (GW).
 2. Total capacity for the year may not agree with the sum of each energy source because of being rounded off.
 3. City gas is classified into LNG/LPG after FY1996.
 4. The figures for new energy etc. consist of wind, photovoltaic and waste power generation before FY2008 (facilities with expected supply capacity and TEPCO's approved facilities). The figures added geothermal and biomass power generation after FY2009 (facilities with expected supply capacity and TEPCO's approved facilities).
 5. On April 19, 2012, following the notification of decommissioning submitted on March 30, 2012 in accordance with Article 9 of the Electric Utilities Industry Law, out of the nuclear plants owned by TEPCO, Units 1-4 (2,812MW) at Fukushima Daiichi Nuclear Power Station were decommissioned. As of the end of March 2012, the output of these units was included.

<Reference> Combining of Energy Sources to Meet Changing Demand

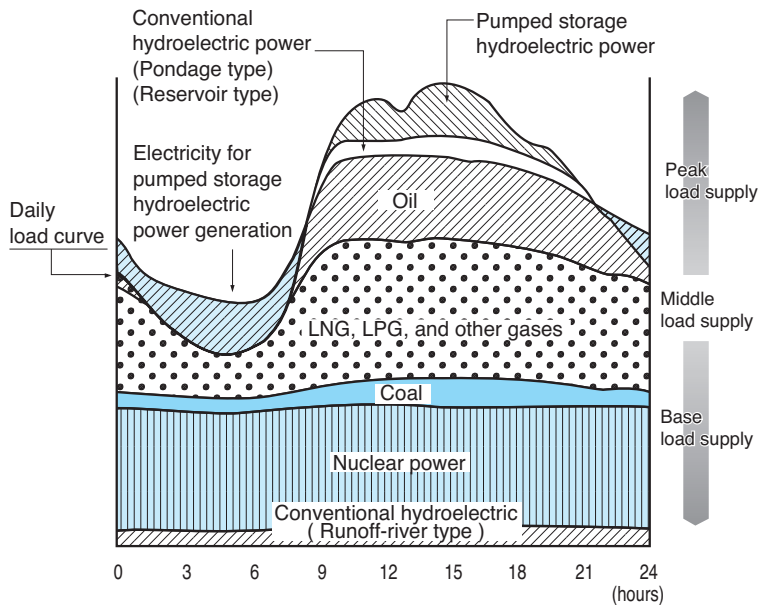

- Nuclear power: TEPCO utilizes it as a base load supply due to its greater stability, economical fuel supply situation and its environmental preservation advantage while keeping safety as the first target.
- Coal thermal power: TEPCO promotes its long term development as a base load supply considering its environmental impact from the viewpoint of diversification of electric power sources and due to its higher stability and economical fuel supply situation.
- LNG thermal power: TEPCO promotes its development as an urban type electric power source near demand areas for middle and base load supplies with aiming the high-efficiency power generation due to its excellent environmental adaptability and operability as compared with other fossil fuels.
- Oil thermal power: TEPCO ensures proper capacity for peak load supply by extending the service life of present facilities due to its quick operational response to variations in demand and its flexible fuel supply buffer function.
- Pumped storage hydroelectric power: TEPCO utilizes it as an economic and reliable peak load supply due to its excellent load traceability and a power storage-operations function.
- Conventional hydroelectric power: TEPCO promotes its development with careful consideration of harmony with nature and economic efficiency in view of its advantages as a purely domestic renewable energy source and its lower environmental impact.

c. Power Source Shares by Country

Energy Source Power Output Composition by Country (Part 1)

(Unit: TWh)

1980

2009

Japan
572.5

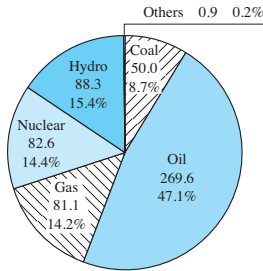

1,041.0

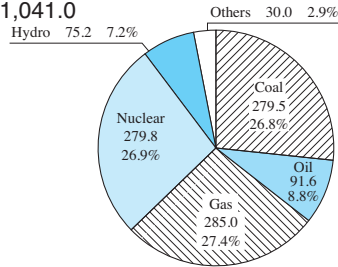

France
256.9

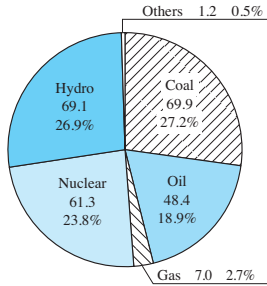

537.4

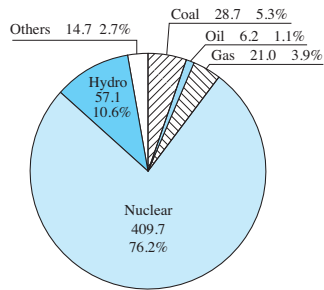

U.S.A.
2,427.3

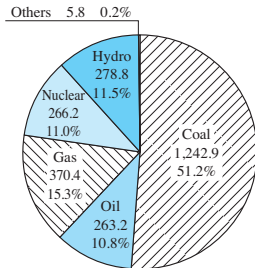

4,165.4

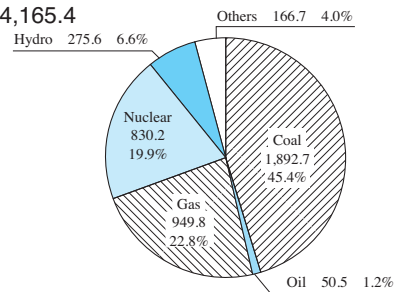

U.K.
284.1

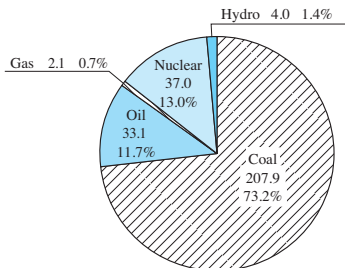

372.0

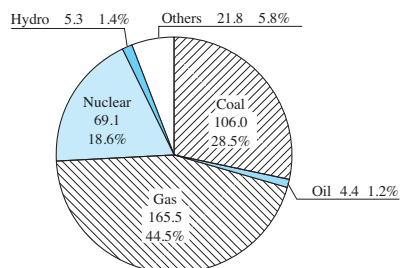

Source: "Energy Balances of OECD Countries 2011 edition," IEA.

Energy Source Power Output Composition by Country (Part 2)

(Unit: TWh)

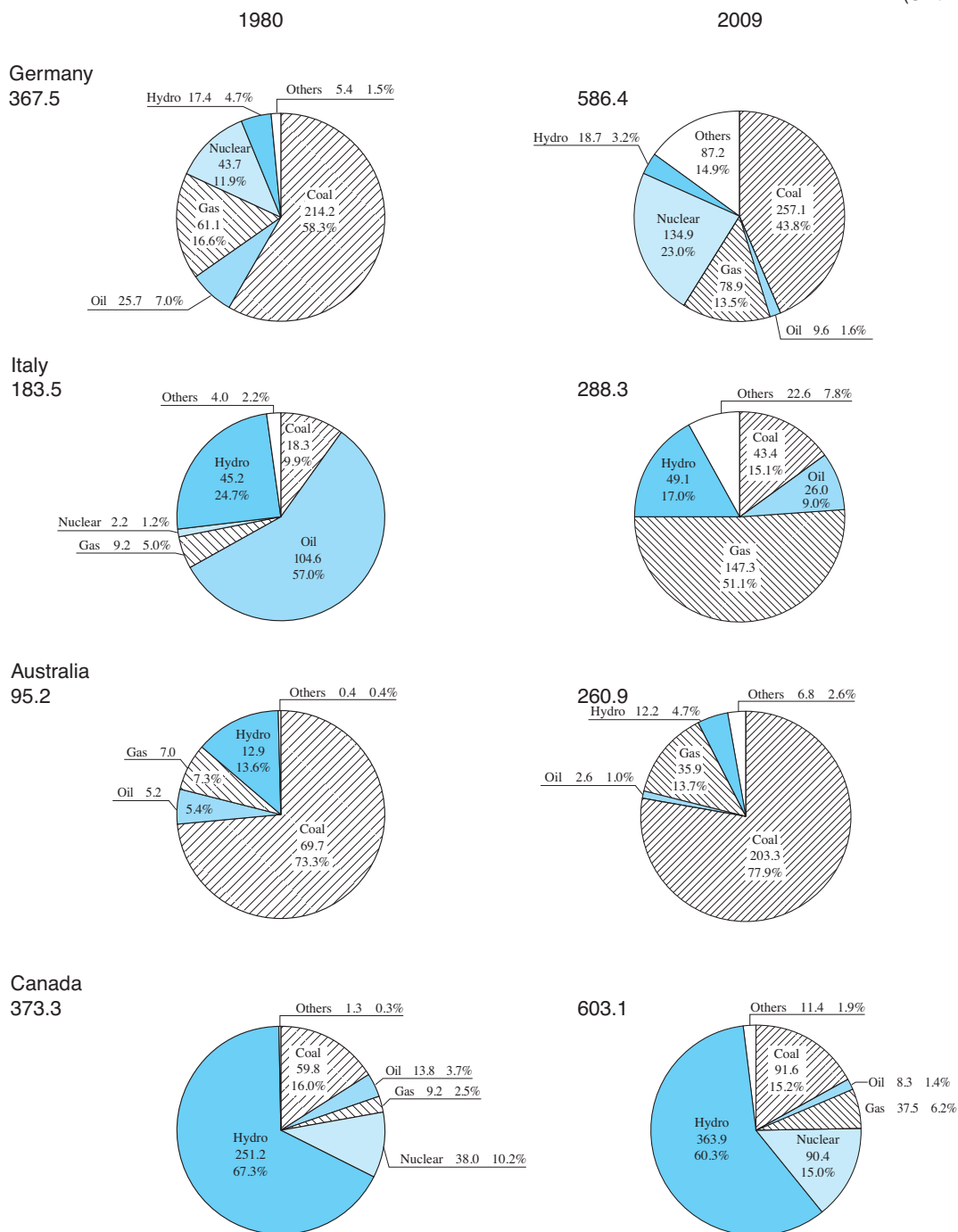

Note: Germany : Figures given for 1980 are for the former West Germany

Source: "Energy Balances of OECD Countries 2011 edition," IEA.

d. Development Status of Overseas Business
 [Major Overseas Investment Activities (Power Generation)]

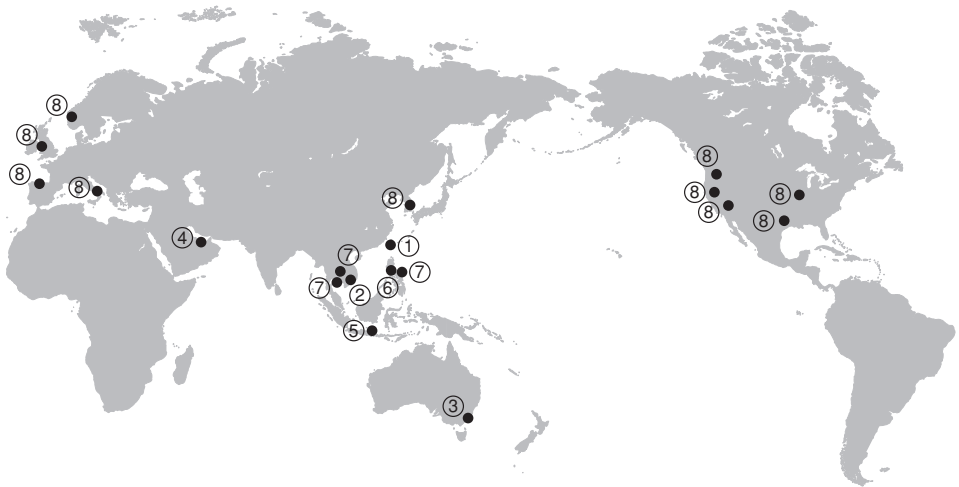

Countries and Regions	Projects etc.	Installed Capacity
Taiwan	① Chang Bin, Fong Der and Star Buck Project	Chang Bin 490MW, Fong Der 980MW Star Buck 490MW
Vietnam	② Phu My 2-2 Project	715MW
Australia	③ Loy Yang A Project	2,200MW
U.A.E.	④ Umm Al Nar Power and Water Project	2,200MW
Indonesia	⑤ Paiton I, III Project	Paiton I : 1,230MW, Paiton III : 815MW
Philippines	⑥ TeaM Energy Project	3,204MW
Thailand	⑦ EGCO Project	4,516MW
U.S.A., Europe, Asia	⑧ Eurus Energy	2,131MW (wind power generation etc.)

- Notes: 1. As of the end of March 2012.
 2. Installed Capacity means the sum of power output of power generating facilities.

Changes in Total Generation Capacity of Overseas Projects

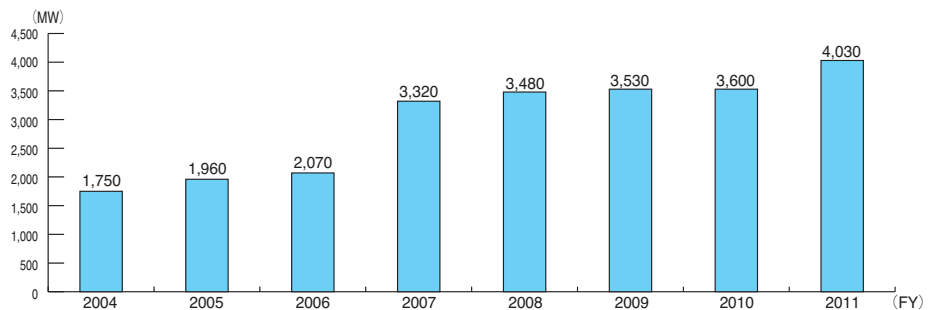

- Notes: 1. Figures include that of Eurus Energy Holdings.
 2. The sum of the power output of each power generation company multiplied by TEPCO's shareholding ratio in the respective company.
 3. As of the end of March of every fiscal year.

[Recent Major Overseas Consulting Services]

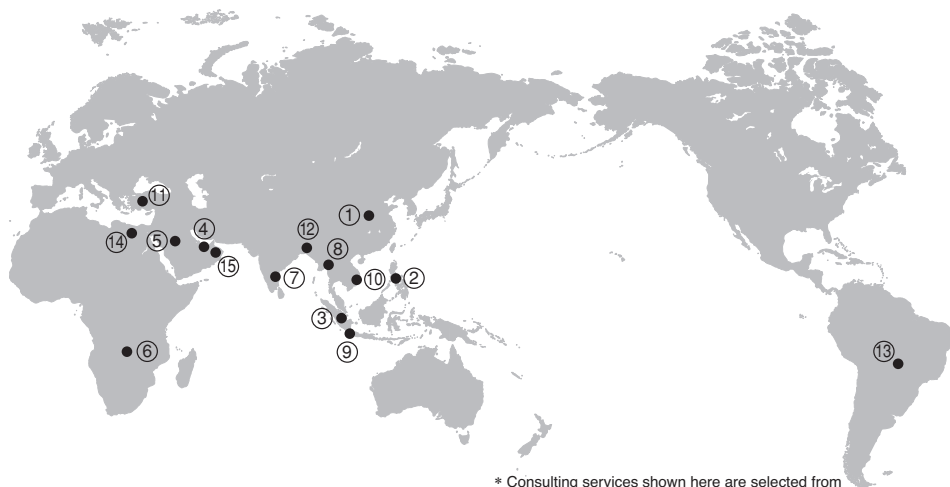

* Consulting services shown here are selected from those already conducted and those underway

Countries and Regions	Projects etc.	Ordering Parties / Companies Supported by TEPCO, etc.
China	① UHV Transmission System Design	STATE GRID CORPORATION of CHINA
Philippines	② Development Study on Energy Efficiency and Conservation for the Philippines	Department of Energy (JICA)
Malaysia	③ Examination of Solar Power with Battery	Tenaga Nasional Berhad (TNB) (NEDO)
U.A.E.	④ The Master Plan Study of Transmission System	Abu Dhabi Transmission & Dispatch Company (TRANSCO)
Saudi Arabia	⑤ The Master Plan Study for Energy Conservation	Ministry of Water and Electricity (JICA)
Zambia	⑥ Rural Electrification Master Plan Study	Ministry of Energy and Water Development (JICA)
India	⑦ Transmission System Improvement Project	Tamilnadu Transmission Corporation Ltd. (JICA)
Myanmar	⑧ The Preparatory Survey on the Project for Rehabilitation of Hydro Power Plant	Ministry of Electric Power No. 1 & 2 (JICA)
Indonesia	⑨ Preparatory Survey for Bakaru Hydroelectric Power Plant ehabilitation and Extention Project	PLN (Perusahaan Listrik Negara) (JICA)
Vietnam	⑩ Ultra Super Critical Coal Fired Power Technology Project	Ministry of Industry and Trade (METI, NEDO)
Turkey	⑪ The Study on Optimal Power Generation For Peak Demand in Turkey	JICA
Bangladesh	⑫ The Study for Master Plan on Coal Power Development in the People's Republic of Bangladesh	JICA
Brazil	⑬ Study on Collection of Basic Information Concerning Smart Grid	The Ministry of Energy and Mines etc. (JICA)
Egypt	⑭ Energy Control System Upgrading Project	Egyptian Electricity Transmission Company (EETC)
Oman	⑮ Investigation of Electricity Energy Saving Master Plan	Public Authority for Electricity and Water etc. (JICA)

Changes in Sales and Number of Contracts of Overseas Consulting Services

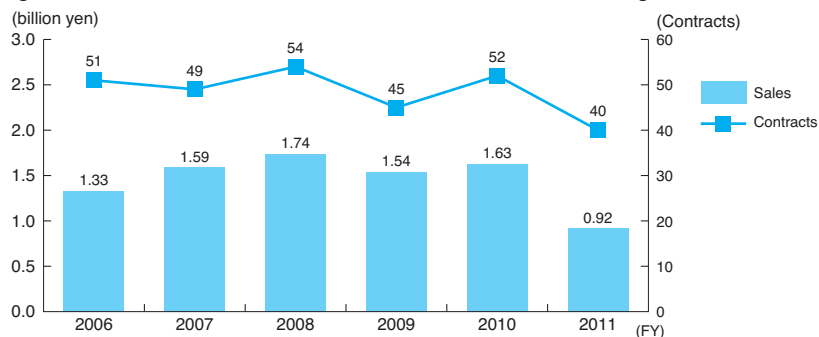

(3) Major Power Generation Facilities

a. Hydroelectric Power (with a capacity of more than 50MW)

(as of the end of March 2012)

Station Name	Location	Plant Capacity (MW)	Single Unit Capacity (1,000 kVA)	Type
Imaichi	69 Sagebukokuyurin, Nikko, Tochigi Pref.	1,050	390× 3 units	Dam and conduit type (pumped storage type)
Kinugawa	706 Kinugawaonsentak, Nikko, Tochigi Pref.	127	66× 2 units	Conduit type
Shiobara	453 Nishiyamakokuyurin, 1425-1 Azanishiyama, Sekiya, Nasushiobara, Tochigi Pref.	900	335× 2 units 360× 1 unit	Dam and conduit type (pumped storage type)
Yagisawa	6381-2 Fujiwara Azayagisawa, Minakami-machi, Tone-gun, Gunma Pref.	240	85× 3 units	Dam type (pumped storage type)
Tanbara	78 · 79 Fujiwara Azaootonekokuyurin, Minakami-machi, Tone-gun, Gunma Pref.	1,200	335× 4 units	Dam and conduit type (pumped storage type)
Saku	654 Makabe Azatutubashima, Hokkito-machi, Shibukawa, Gunma Pref.	76.8	28× 3 units 7.6× 1 unit	Conduit type
Kannagawa	3577 Ooazanarahara Azahontani, Ueno-mura, Tano-gun, Gunma Pref.	470	525× 1 unit	Dam and conduit type (pumped storage type)
Kazunogawa	3064-1 Seto Azakoganezawa Tuchimuro, Nanaho-machi, Otsuki, Yamanashi Pref.	800	475× 2 units	Dam and conduit type (pumped storage type)
Hayakawa Daiichi	54-2 Kuretsubo, Hayakawa-cho, Minamikoma-gun, Yamanashi Pref.	51.2	8× 4 units 25× 1 unit	Conduit type
Akimoto	304 Ooazawakamiya Azasekikitakou, Inawashiro-machi, Maya-gun, Fukushima Pref.	107.5	31× 2 units 60.8× 1 unit	Conduit type
Inawashiro Daiichi	2 Hata Azaawabatake, Kawahigashi-machi, Aizuwakamatsu, Fukushima Pref.	62.4	23.4× 3 units 3.8× 1 unit	Conduit type
Azumi	3571-3 Azumi, Matsumoto, Nagano Pref. 4442-10 Nagawa, Matsumoto, Nagano Pref.	623	111× 2 units 109× 4 units	Dam type Dam and conduit type (pumped storage type)
Midono	3081-226 Azumi, Matsumoto, Nagano Pref.	245	65× 2 units 65× 2 units	Dam type Dam type (pumped storage type)
Shin-Takasegawa	2118-2 Taira Azatakaseiri, Omachi, Nagano Pref.	1,280	367× 4 units	Dam and conduit type (pumped storage type)
Nakatsugawa Daiichi	279-3 Ooazakettou, Tsunan-machi, Nakauonuma-gun, Niigata Pref.	126	16.7× 3 units 91× 1 unit	Conduit type
Shinanogawa	550-1 Ooazasangakou, Tsunan-machi, Nakauonuma-gun, Niigata Pref.	169	39× 5 units	Conduit type

b. Thermal Power

(as of the end of March 2012)

Station Name	Location	Authorized Maximum Capacity (MW)	Single Unit Capacity (MW)	Fuels in Use
Chiba	2-1377 Soga-cho, Chuo-ku, Chiba, Chiba Pref.	2,880 〔668〕	360× 8 units (1,440× 2 groups) 〔334× 2 units〕	LNG 〔LNG〕
Goi	1 Goi Kaigan, Ichihara, Chiba Pref.	1,886	265× 4 units 350× 1 unit 476× 1 unit	LNG LNG LNG
Anegasaki	3 Anegasaki Kaigan, Ichihara, Chiba Pref.	3,600 〔5.6〕	600× 2 units 600× 2 units 600× 2 units 〔1.4× 4 units〕	LNG, heavy oil, crude oil Heavy oil, crude oil, LNG, LPG, NGL, LNG, LPG 〔Light oil〕
Sodegaura	2-1 Nakasode, Sodegaura, Chiba Pref.	3,600 〔112.2〕	600× 1 unit 1,000× 3 units 〔1.1× 102 units〕	LNG LNG 〔LNG〕
Futtsu	25 Shintomi, Futtsu, Chiba Pref.	5,040	165× 14 units (1,000× 2 groups) 380× 4 units (1,520× 1 group) 507× 3 unit (1,520× 1 group)	LNG LNG LNG
Yokosuka	9-2-1 Kurihama, Yokosuka, Kanagawa Pref.	2,274 〔329.6〕	350× 6 units 30× 1 unit 144× 1 unit 〔23.2× 3 units〕 〔26.3× 7 units〕 〔25.3× 3 units〕	Heavy oil, crude oil Light oil City gas, light oil 〔Light oil〕
Kawasaki	5-1 Chidori-cho, Kawasaki-ku, Kawasaki, Kanagawa Pref.	1,500 〔128〕	500× 3 units (1,500× 1 group) 〔128× 1 unit〕	LNG 〔LNG〕
Yokohama	11-1 Daikoku-cho, Tsurumi-ku, Yokohama, Kanagawa Pref.	3,325	175× 1 unit 350× 1 unit 350× 8 units (1,400× 2 groups)	LNG, heavy oil, crude oil, NGL LNG, heavy oil, crude oil, NGL LNG
Minami Yokohama	37-1 Shin Isogo-cho, Isogo-ku, Yokohama, Kanagawa Pref.	1,150	350× 2 units 450× 1 unit	LNG LNG
Higashi Ohgishima	3 Higashi Ohgishima, Kawasaki-ku, Kawasaki, Kanagawa Pref.	2,000	1,000× 2 units	LNG
Kashima	9 Higashi Wada, Kamisu, Ibaraki Pref.	4,400	600× 4 units 1,000× 2 units	Heavy oil, crude oil Heavy oil, crude oil
Ohi	1-2-2 Yashio, Shinagawa-ku, Tokyo	1,050 〔209〕	350× 3 units 〔81× 1 unit〕 〔128× 1 unit〕	Crude oil 〔City gas〕
Hirono	58 Futatsu Numa, Shimokitaba, Hirono-machi, Futaba-gun, Fukushima Pref.	3,800	600× 1 unit 600× 1 unit 1,000× 2 units 600× 1 unit	Heavy oil, crude oil Heavy oil, crude oil Heavy oil, crude oil Coal
Shinagawa	5-6-22 Higashi Shinagawa, Shinagawa-ku, Tokyo	1,140	380× 3 units (1,140× 1 group)	City gas
Hitachinaka	768-23 Terunuma, Tokai-mura, Naka-gun, Ibaraki Pref.	1,000	1,000× 1 unit	Coal

Notes: The figures in parenthesis are for the urgent installed generation facilities.

c. Nuclear Power

(as of the end of March 2012)

Station Name	Location	Plant Capacity (MW)	Single Unit Capacity (MW)	Type	Fuels in Use
Fukushima Daiichi (*)	22 Kitahara, Ottozawa, Ohkuma-machi, Futaba-gun, Fukushima Pref. (approx. 3,500,000 m ²)	4,696	460 × 1 unit 784 × 4 units 1,100 × 1 unit	BWR BWR BWR	Uranium dioxide sintered pellets
Fukushima Daini	12 Kohamasaku, Namikura, Naraha-machi, Futaba-gun, Fukushima Pref. (approx. 1,500,000 m ²)	4,400	1,100 × 4 units	BWR	Uranium dioxide sintered pellets
Kashiwazaki-Kariwa	16-46 Aoyama-cho, Kashiwazaki, Niigata Pref. (approx. 4,200,000 m ²)	8,212	1,100 × 5 units 1,356 × 2 units	BWR ABWR	Uranium dioxide sintered pellets

* On April 19th, 2012, following the notification of decommissioning submitted on March 30, 2012 in accordance with Article 9 of the Electric Utilities Industry Law, Units 1-4 (2,812MW) at Fukushima Daiichi Nuclear Power Station were decommissioned.

d. New Energy

(as of the end of March 2012)

Station Name	Location	Plant Capacity (MW)	Single Unit Capacity (MW)
Hachijyoujima Geothermal	2872 Nakanogou, Hachijyou-machi, Hachijyoujima, Tokyo	3.3	3.3 × 1 unit
Hachijyoujima Wind Power	2872 Nakanogou, Hachijyou-machi, Hachijyoujima, Tokyo	0.5	0.5 × 1 unit
Ukishima Photovoltaic Power	507 Ukishima-cho, Kawasaki-ku, Kawasaki, Kanagawa Pref.	7	-
Ohgishima Photovoltaic Power	1-4 Ohgishima, Kawasaki-ku, Kawasaki, Kanagawa Pref.	13	-
Komekurayama Photovoltaic Power	3443-1 Shimomukouyama-cho, Kofu, Yamanashi Pref.	10	-

(4) Electricity Generated and Purchased

(Unit: TWh)

FY	1970	1975	1980	1985	1990	1995	2000	2001	2002	2003	2004	2005	2006	2007	2008	2009	2010	2011
	Hydro (percentage composition, %) (flow rate, %)	11.1 (14.4) <92.4>	10.6 (11.1) <100.5>	11.2 (9.1) <101.7>	11.2 (6.8) <96.5>	12.6 (5.7) <103.0>	12.7 (5.1) <90.0>	13.7 (5.2) <101.5>	13.7 (5.3) <101.1>	12.5 (5.0) <98.3>	12.6 (5.4) <107.4>	12.8 (4.9) <110.5>	11.7 (4.3) <94.2>	12.9 (4.8) <102.9>	12.1 (4.4) <94.4>	10.7 (4.1) <95.8>	10.1 (4.0) <94.5>	11.3 (4.3) <101.3>
Thermal (percentage composition, %)	65.2 (85.2)	80.1 (83.9)	85.9 (70.0)	96.9 (58.7)	131.8 (59.5)	129.6 (52.0)	131.5 (49.5)	121.8 (47.4)	149.2 (58.8)	181.2 (77.5)	155.5 (59.4)	157.3 (58.4)	145.6 (53.7)	193.1 (70.6)	182.7 (70.3)	161.2 (63.9)	168.9 (64.0)	210.3 (84.4)
Nuclear (percentage composition, %)	0.3 (0.4)	4.7 (5.0)	25.6 (20.9)	56.9 (34.5)	77.1 (34.8)	106.9 (42.9)	120.4 (45.3)	121.5 (47.3)	92.0 (36.2)	39.9 (17.1)	93.5 (35.7)	100.7 (37.3)	112.5 (41.5)	68.3 (25.0)	66.3 (25.6)	80.9 (32.1)	83.8 (31.7)	28.1 (11.3)
Wind Power (percentage composition, %)	-	-	-	-	-	-	0 (0.0)	0 (0.0)	0 (0.0)	0 (0.0)	0 (0.0)	0 (0.0)	0 (0.0)	0 (0.0)	0 (0.0)	0 (0.0)	0 (0.0)	0 (0.0)
Total Generated	76.6	95.4	122.7	165.0	221.5	249.2	265.6	257.0	253.7	233.7	261.8	269.7	271.0	273.5	259.7	252.2	264.0	249.2
Total Purchased	11.9	16.2	21.4	22.6	27.3	33.7	36.2	32.9	38.9	44.9	41.3	36.1	36.6	43.0	47.5	44.1	49.5	42.7
Exchange	-0.6	1.2	0.9	-2.5	-0.7	4.4	11.6	17.2	20.2	24.0	12.8	12.1	9.5	12.4	9.3	9.9	5.8	1.3
Used at Pumped Storage	-2.1	-0.2	-1.1	-3.0	-6.0	-8.1	-7.7	-7.6	-5.5	-2.9	-4.1	-4.5	-4.4	-5.8	-2.3	-1.7	-2.7	-2.4
Total Generated and Purchased	85.8	112.6	143.9	182.1	242.1	279.2	305.7	299.5	307.3	299.7	311.8	313.4	312.7	323.1	314.2	304.5	316.6	290.8
Used in Power Stations <station service power rate, %>	3.1 <4.0>	3.6 <3.7>	4.9 <4.0>	6.9 <4.1>	9.1 <4.1>	10.3 <4.1>	10.2 <3.9>	9.8 <3.8>	9.5 <3.8>	9.4 <4.0>	10.3 <3.9>	10.3 <3.8>	10.2 <3.8>	10.2 <3.7>	9.7 <3.7>	9.7 <3.8>	9.8 <3.7>	8.5 <3.4>
Transmission End Supply Capacity	82.7	109.0	139.0	175.2	233.0	268.9	295.5	289.7	297.8	290.3	301.5	303.1	302.5	312.9	304.5	294.8	306.8	282.3
Total Loss Factor (%) <transmission and distribution loss rate>	10.0 <6.5>	9.2 <6.1>	8.9 <5.5>	9.2 <5.5>	9.2 <5.4>	8.9 <5.2>	8.2 <4.9>	8.0 <4.7>	8.3 <5.2>	7.9 <4.8>	8.0 <4.7>	7.9 <4.6>	8.0 <4.8>	8.0 <4.8>	8.0 <4.9>	8.0 <4.8>	7.4 <4.2>	7.8 <4.8>
Power Demand (electricity sold)	77.3	102.2	131.1	165.3	219.9	254.4	280.7	275.5	281.9	276.0	286.7	288.7	287.6	297.4	289.0	280.2	293.4	268.2

- Notes:
1. Figures in parentheses represent the percentage composition of TEPCO's own power output.
 2. The sum total of numerical values given in the columns may not agree with the figures given in the total column because fractions are rounded off.
 3. Figures for thermal power include geothermal power.
 4. Figures for wind power generation were obtained from the Hachijojima Wind Power Generation Plant. (500 kW. Operation started on March 31, 2000.)

(5) Changes in Power Output Composition by Energy Sources (TEPCO including purchased power)

a. TEPCO

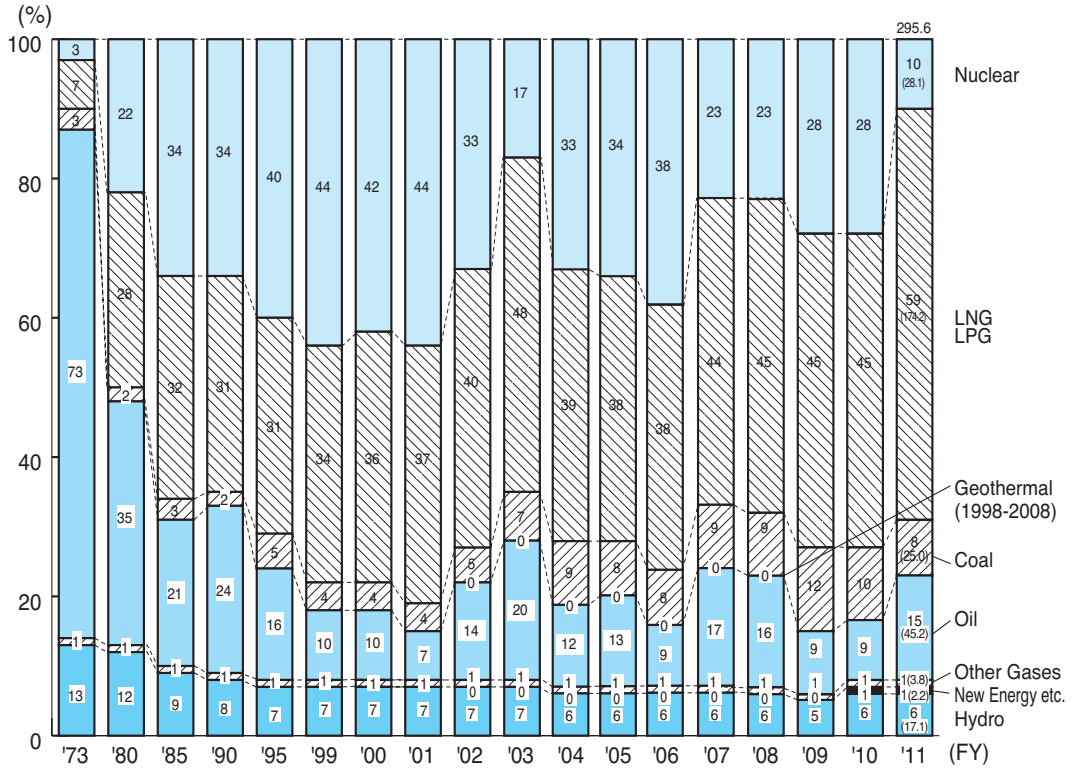

- Notes:
1. Figures in parentheses for FY2011 are electricity generated (TWh).
 2. The figures for new energy etc. consist of wind, photovoltaic and waste power generation before FY2008. The figures added geothermal and biomass power generation after FY2009.

b. 10 Electric Power Companies

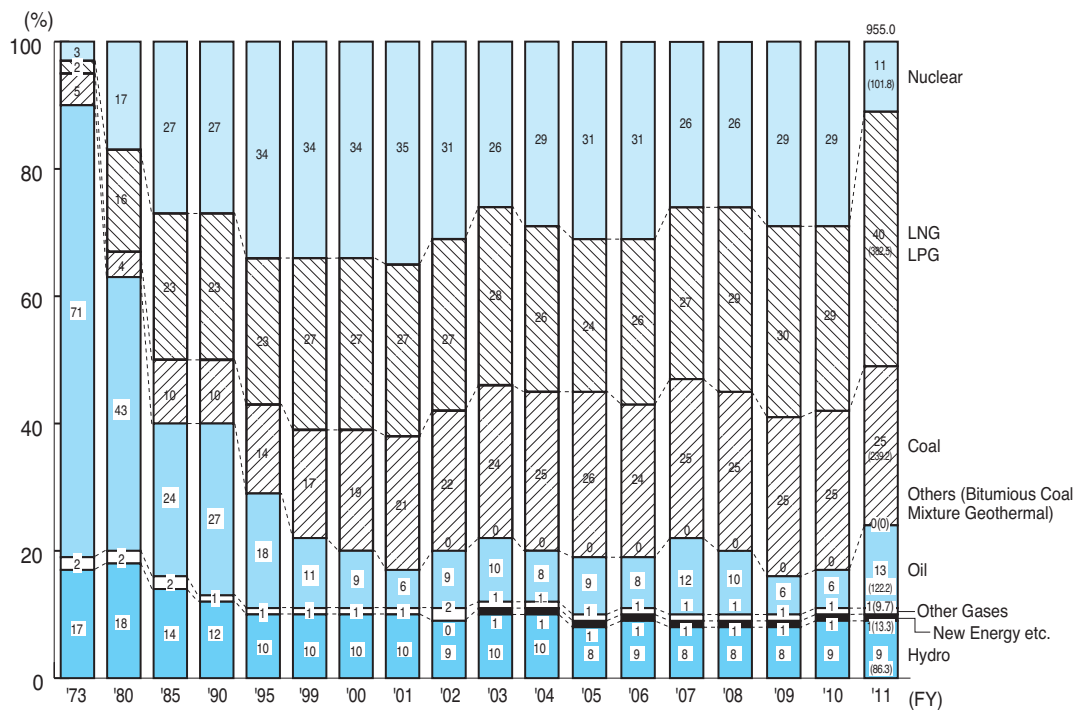

- Notes:
1. Figures in parentheses are electricity generated (TWh).
 2. Totals may not agree with the sum of each energy source because of being rounded off. (The sum of the values in each bar is adjusted to 100%.)
 3. Figures are given for a total of 9 power companies (except Okinawa Power Company) before 1985.
 4. The figures for new energy etc. consist of wind, photovoltaic and waste power generation before FY2008. The figures added geothermal and biomass power generation after FY2009.

(6) Electric Power Development Program

a. Demand Outlook

(Unit: TWh)

		FY	2011	2012	2013	2016	2021	Yearly Average Increase Rate
			(actual)					2021/2011
TEPCO	Demand Other than Specified-Scale	Lighting	95.8	94.6	95.8	98.5	102.1	0.6%
		Power	11.2	10.2	10.0	9.5	8.6	-2.5%
	Total of Lighting and Power	107.0	104.9	105.8	108.0	110.7	0.3%	
	Specified-Scale Demand	161.3	167.4	172.6	178.0	192.9	1.8%	
	Total Demand	268.2	272.3	278.4	286.0	303.7	1.2%	

- Notes:
1. Figures are quoted from Comprehensive Special Business Plan.
 2. Specified-scale demand includes contracts for at least, 50kW.
 3. Total demand figures may not agree with the sum of each item because of being rounded off.

b. Peak Demand Outlook

(Unit: GW)

		FY	2011	2012	2013	2016	2021	Yearly Average Increase Rate
			(actual)					2021/2011
TEPCO			47.67	51.38	52.82	54.54	58.02	2.0%

- Notes:
1. "Peak demand" here represents the maximum three-day average peak load in Summer at transmission end.
 2. Figures are quoted from Comprehensive Special Business Plan.

<Reference> Summary of Power Plant Siting Procedure (example of nuclear power station)

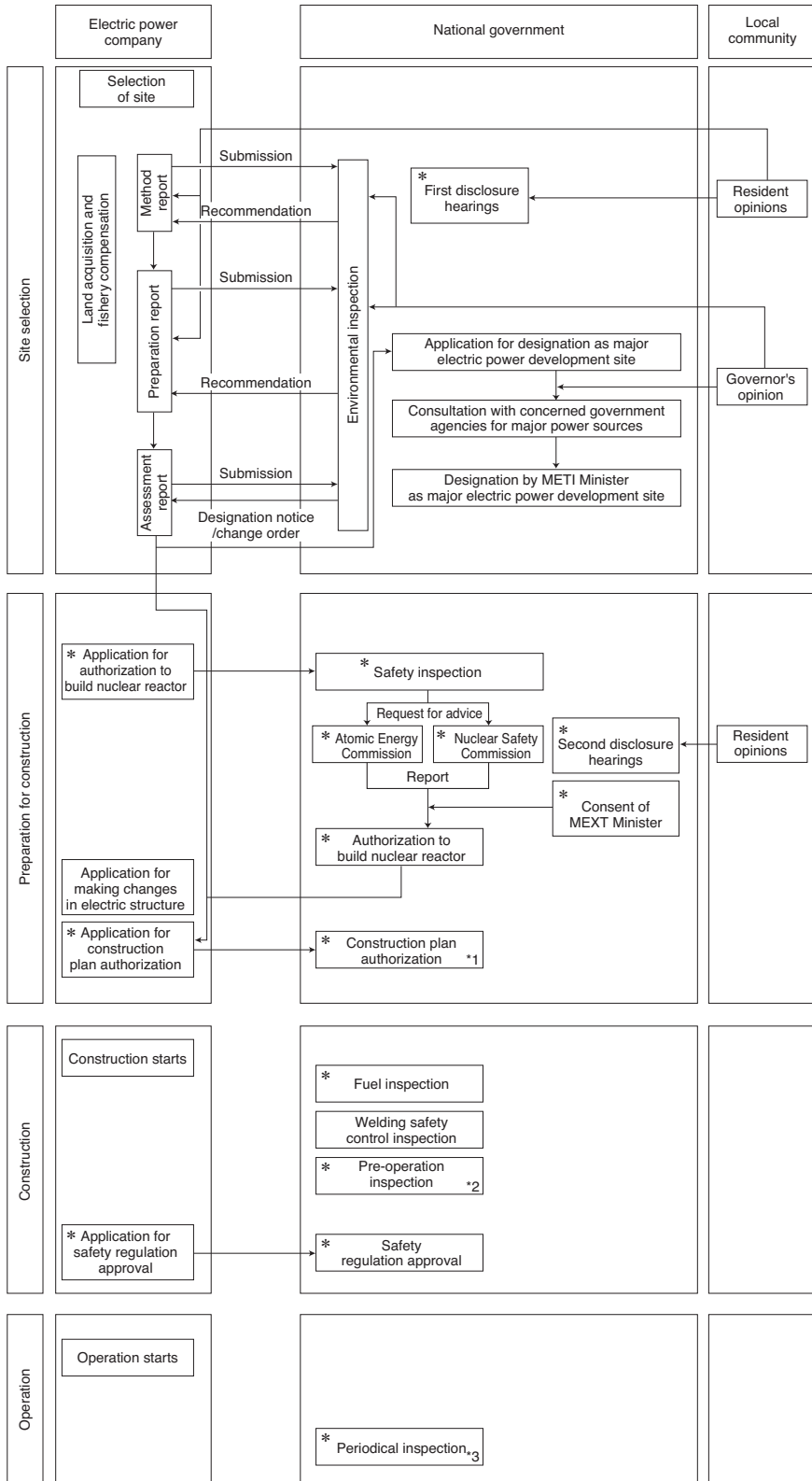

*1 For power plant other than nuclear, its construction plan is presented from an electric power supplier.

*2 For power plant other than nuclear, pre-operation safety control inspection is required.

*3 For power plant other than nuclear, periodical safety control inspection is required.

*4 Items marked with * are the procedure relevant to nuclear plant.

(7) Wide Area Coordination System Operation

a. Purpose

Implement facility development and business operation efficiently through mutual corporation of electric power companies.

b. Recent Situations

○ Wide area development

Tohoku Electric Power's Higashidori Power Plant Unit 1 (1,100 MW), in which TEPCO participated, began operation on December 8, 2005.

○ Inter-service area power exchange

TEPCO continues to exchange power with Tohoku Electric Power Company.

○ Wide area connection

• 50 Hz

Operation of the Soma Futaba Trunk Line began in June 1995 to link the Tohoku and Tokyo regions at 500 kV.

• 60 Hz

Part of the frequency conversion facility at Chubu Electric Power's Higashi-Shimizu Frequency Conversion Station began operation in March 2006.

<Reference> Classification of Power Exchange

Nationwide exchange (among 9 EP Co.)	• Power exchange for resource shortage	Power to be exchanged to make up for shortages by the request of receiving company.
	• Power exchange for mutual benefit or oversupply	Power to be exchanged to achieve reasonable operations of electric power facilities and equipments by taking advantage of differences between power sending and receiving companies in terms of demand time period, supply capacity composition, or power to be exchanged to make effective use of surplus power of a sending company.
Bilateral exchange	• Power exchange for system operation	Power to be exchanged to make effective use of electric power facilities near the neighboring company's service area (to be supplied in the same quantity at the same time in principle).
	• Power exchange for maintenance work and testing	Power to be exchanged for maintenance works and testings of network facilities.
	• Specified power exchange	Power to be exchanged for specific power generating facilities or for customers in specific area, and power to be exchanged according to long-term schedule for wide-area coordination.

c. History of Wide Area Coordination System Operation at TEPCO

<p>Mid-1950's to mid-1960's: Era of energy shortages</p>	<p>Development of large-scale general hydroelectric power in border areas through Electric Power Development Co., Ltd. Sakuma River system hydropower development (inc. Sakuma Hydro Power, 350MW). Power received by TEPCO and Chubu Electric Power Tadami River system hydropower development (inc. Tagokura Dam, 380MW, and Okutadami Dam, 360MW) Power received by TEPCO and Tohoku Electric Power</p>
<p>Second half of 1960's</p>	<p>Cooperation on coal policy and effective use of coal resources Electric Power Development Company Isogo Units 1, 2 (265MW x 2, ceased commercial operations in November 2001). Joban Joint Power Nakoso Units 6, 7 (175MW, 250MW) Power received by TEPCO and Tohoku Electric Power Start of first commercial nuclear power generation in Japan Japan Atomic Power Company Tokai (gas cooled reactor: 166MW; ceased commercial operations at the end of FY1997)..... All power received by TEPCO Linking regions with different frequencies allows the companies that are linked to reduce power generation equipment and make their overall operations more practical and economical Electric Power Development Company Sakuma Frequency Converter Station (300MW)</p>
<p>First half of 1970's (first new expansion of super-regional management)</p>	<p>Pursuing effective use of power sites and economies of scale Electric Power Development Company Shintoyone Pumped Storage Power Station (hydropower) (1,125MW) Power received by TEPCO and Chubu Electric Power Tohoku Electric Power Shinsendai Unit 2 (600MW) Part of power generated received by TEPCO</p>
<p>Second half of 1970's (second new expansion of super-regional management)</p>	<p>Pursuing diversification of power sources by developing alternatives to oil Joban Joint Power Nakoso Units 8, 9 (600MW x 2) Power received by TEPCO and Tohoku Electric Power TEPCO Kashiwazaki-Kariwa Unit 1 (1,100MW) Part of power generated sent to Tohoku Electric Power TEPCO Fukushima Daini Units 3, 4 (1,100MW x 2) Part of power generated sent to Tohoku Electric Power Development of high-volume nuclear power (promotion of new technologies) Japan Atomic Power Company Tokai Daini (1,100MW) Power received by TEPCO and Tohoku Electric Power Linking regions with different frequencies allows the companies that are linked to reduce power generation equipment and make their overall operations more practical and economical TEPCO Shin-Shinano Frequency Converter Station (300MW) Efforts being made to step up electric power flexibility by treating the entire nation as one power system, thereby providing power companies with benefits such as the ability to reduce power generation equipment, making their overall operations more practical and economical Electric Power Development Company Hokkaido/Honshu Connection Line (300MW)</p>
<p>Second half of 1980's to present (third new expansion of super-regional management)</p>	<p>Securing power supply through development in border areas Electric Power Development Company Shimogo Pumped Storage Power Station (hydropower) (1,000MW) Power received by TEPCO and Tohoku Electric Power Electric Power Development Company Tadami Hydroelectric Power Station (65MW) Promoting oil alternatives and regional advancement Soma Kyodo Power Company Shinchi Units 1 (1,000MW) and 2 (1,000MW) Electric Power Development Company Isogo New Unit 1 (600MW) Further strengthening of inter-regional and inter-company collaborations Expansion of TEPCO Shin-Shinano Frequency Converter Station (300 MW; total capacity upon expansion 600 MW) Electric Power Development Company Hokkaido/Honshu Connection Line expansion (300MW; total capacity upon expansion 600MW). New installation of TEPCO/Tohoku Electric Power's Soma Futaba Trunk Line Expansion (Tokyo/Tohoku 500 kV connection) New installation of Chubu Electric Power's Higashi Shimizu Frequency Conversion Station (part of 300 MW operation began) Wide area development of nuclear power plant Tohoku Electric Power's Higashidori Power Plant Unit 1 (1,100 MW) part of generated power is received by TEPCO</p>

d. Current Situation of Interconnection for Wide-Area Operation

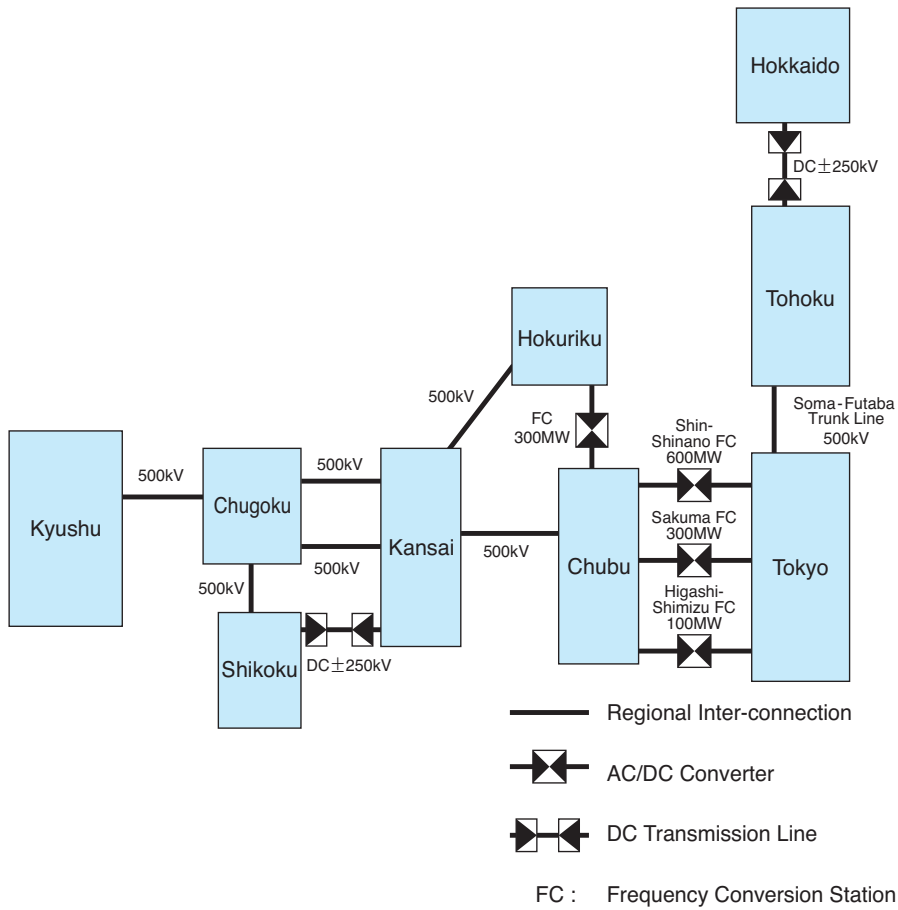

(8) Summary of Bid System for Wholesale Supply of Electric Power

a. Screening Results

	Invitation for Bids	Bids	Successful Bids
FY1996	1,000MW	3,860MW (31 bids)	1,100MW (8 companies)
FY1997	1,000MW	5,860MW (30 bids)	1,080MW (4 companies)
FY1999	1,000MW	2,510MW (11 bids)	1,000MW (5 companies)

b. List of Successful Bidders

① Successful Bidders for FY1996 (Chronological order)

Supplier Name	Location	Maximum Contracted Capacity	Supply Commencement Year	Power Supply Type	Main Fuel
Ebara Corporation	Fujisawa, Kanagawa Prefecture	64.0 MW	1999	Middle	City gas
Showa Denko, K. K.	Kawasaki, Kanagawa Prefecture	124.2 MW	1999	Base	Residual oil
Tomen Power Samukawa Corporation	Koza-gun, Kanagawa Prefecture	65.5 MW	1999	Middle	Kerosene
Hitachi Zosen Corporation	Hitachioomiya, Ibaraki Prefecture	102.7 MW	1999	Middle	Heavy oil
JX Nippon Oil & Energy Corporation	Yokohama, Kanagawa Prefecture	48.5 MW	2000	Middle	Light cycle oil
Hitachi, Ltd.	Hitachi, Ibaraki Prefecture	102.8 MW	2000	Middle	Heavy oil
Polyplastics Co., Ltd.	Fuji, Shizuoka Prefecture	47.0 MW	2000	Middle	Heavy oil
General Sekiyu K. K.*	Kawasaki, Kanagawa Prefecture	547.5 MW	2001	Base	Residual oil

(Total of maximum contracted capacity: 1,102.2 MW)

* The project was cancelled due to General Sekiyu K.K.'s reasons.

② Successful Bidders for FY1997 (Chronological order)

Supplier Name	Location	Maximum Contracted Capacity	Supply Commencement Year	Power Supply Type	Main Fuel
JFE Steel Corporation	Chiba, Chiba Prefecture	381.8 MW	2002	Middle	City gas
Shinagawa Refractories Co., Ltd.*	Zama, Kanagawa Prefecture	109.5 MW	2002	Middle	City gas
Genex Co., Ltd.	Kawasaki, Kanagawa Prefecture	238.0 MW	2003	Base	By-product gas
JX Nippon Oil & Energy Corporation	Yokohama, Kanagawa Prefecture	342.0 MW	2003	Base	Residual oil

(Total of maximum contracted capacity: 1,071.3 MW)

* The project was cancelled due to Shinagawa Refractories Co., Ltd.'s reasons.

③ Successful Bidders for FY1999 (Chronological order)

Supplier Name	Location	Maximum Contracted Capacity	Supply Commencement Year	Power Supply Type	Main Fuel
Taiheiyo Cement Corp.*	Ofunato, Iwate Prefecture	134.0 MW	2006	Middle	Coal
Tokyo Gas Yokosuka Power Co., Ltd.	Yokosuka, Kanagawa Prefecture	200.2 MW	2006	Middle	City gas
Hitachi, Ltd.	Hitachi, Ibaraki Prefecture	86.1 MW	2006	Middle	Heavy oil Bunker A
Hitachi Zosen Corp.	Hitachioomiya, Ibaraki Prefecture	109.0 MW	2006	Middle	Heavy oil Bunker A
Sumitomo Metal Industries, Ltd.	Kashima, Ibaraki Prefecture	475.0 MW	2007	Base	Coal

(Total of maximum contracted capacity: 1,004.3 MW)

* The project was cancelled due to Taiheiyo Cement Corp.'s reasons.

c. IPP Power Supply Procurement (procurement amount: total and by fiscal year)

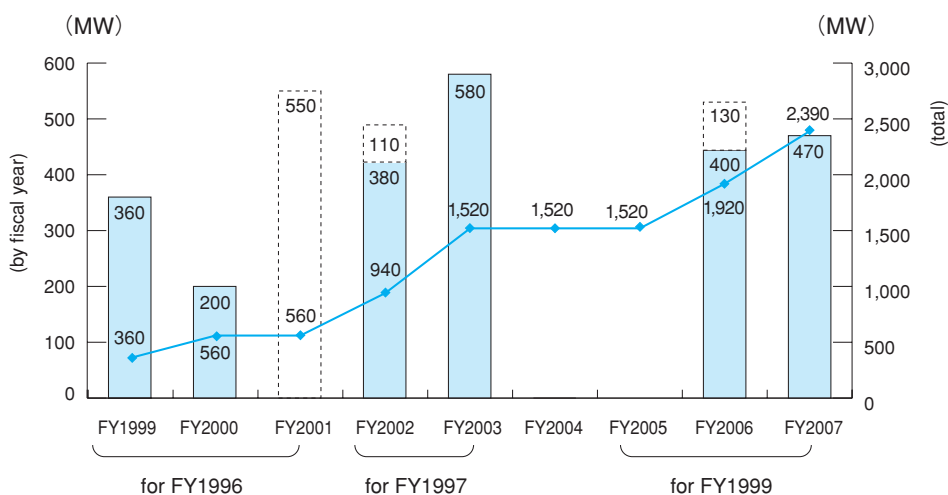

Note: The 550 MW project in FY2001, the 110 MW project in FY2002 and 130 MW project in FY2006 were canceled due to IPP reasons.

2. Transmission and Distribution Facilities

(1) Transmission / Underground Transmission

a. Transmission Facilities by Voltage

(as of the end of March 2012)

Voltage (kV)	Overhead			Underground	
	Route Length (km)	Circuit Length (km)	Number of Supports (units)	Route Length (km)	Circuit Length (km)
500	2,343	4,299	5,030	40	79
275	1,263	2,541	3,566	371	1,094
154	2,986	6,091	10,341	308	755
66	7,713	14,995	25,062	3,499	6,573
Below 55	519	566	7,382	2,074	3,567
Total	14,824	28,492	51,381	6,291	12,067

- Notes:
1. Route length refers to the total length between two points on a line. Circuit length refers to the sum of the route length of each circuit on a line.
 2. Due to the Accounting Rules for Electricity Business amendment (effective from March 29, 2000), distribution facilities with voltage over 20 kV have been included in transmission facilities since FY1999.

b. Underground Transmission Line Installation Rate

At the End of FY	TEPCO			In Tokyo's 23 wards			Total of 10 EP Co.		
	Overhead Lines (km)	Underground Lines (km)	Underground Installation Rate (%)	Overhead Lines (km)	Underground Lines (km)	Underground Installation Rate (%)	Overhead Lines (km)	Underground Lines (km)	Underground Installation Rate (%)
1965	15,379	2,830	15.5	2,301	2,195	48.8	69,042	5,090	6.9
1970	18,393	3,764	17.0	2,331	2,704	53.7	90,553	6,943	7.1
1975	20,636	4,833	19.0	785	3,296	80.8	104,410	8,032	7.1
1980	22,964	5,967	20.6	741	3,783	83.6	115,483	10,143	8.1
1985	24,841	6,548	20.9	695	4,018	85.3	125,154	11,513	8.4
1990	26,126	7,548	22.4	644	4,335	87.1	131,192	13,639	9.4
1995	27,706	8,820	24.1	616	4,949	88.9	138,404	16,304	10.5
2000	28,847	10,933	27.5	619	6,373	91.0	145,020	19,645	11.9
2003	28,693	11,120	27.9	606	6,477	91.4	146,135	20,143	12.1
2004	28,661	11,178	28.1	603	6,506	91.5	145,620	20,317	12.2
2005	28,643	11,237	28.2	602	6,567	91.6	145,795	20,551	12.4
2006	28,615	11,325	28.4	585	6,651	91.9	145,948	20,729	12.4
2007	28,563	11,510	28.7	588	6,764	92.0	146,244	21,018	12.4
2008	28,541	11,652	29.0	573	6,769	92.2	146,213	21,345	12.7
2009	28,543	11,767	29.2	578	6,814	92.2	157,445	25,655	14.0
2010	28,556	11,925	29.5	572	6,901	92.3	157,341	25,942	14.2
2011	28,492	12,067	29.8	572	6,975	92.4			

- Notes:
1.
$$\text{Underground installation rate (\%)} = \frac{\text{Total circuit length of underground lines}}{\text{Total circuit length of overhead lines} + \text{Total circuit length of underground lines}} \times 100 (\%)$$
 2. Due to the Accounting Rules for Electricity Business amendment (effective from March 29, 2000), distribution facilities with voltage over 20 kV have been included in transmission facilities since FY1999.
 3. Figures are given for a total of 9 power companies (except Okinawa Electric Power Company) before FY1985.

<Reference> 1MV Designed Power Transmission Lines (UHV: Ultra High Voltage lines)

	Nishi-Gunma Trunk Line	Minami-Niigata Trunk Line
Section	Nishi-Gunma Switching Station - Higashi-Yamanashi Substation	Kashiwazaki-Kariwa Nuclear Power Station - Nishi-Gunma Switching Station
Length	137.7km	110.8km <61.2km>
Voltage and Number of Circuits	1MV design 2 circuits	1MV design 2 circuits <a portion is 500kV>
Power Lines	ACSR 610mm ² , 810mm ² × 8 conductors	ACSR 610mm ² , 810mm ² × 8 conductors <810mm ² × 4 conductors>
Pylons	Number: 217 Height: 111m average	Number: 201 <114> Height: 97m <89m> average
Start of Construction	September 1988	March 1989
Start of Operations	April 1992	October 1993

Note: Contents in brackets apply to sections designed for 500kV

	Higashi-Gunma Trunk Line	Minami-Iwaki Trunk Line
Section	Nishi-Gunma Switching Station - Higashi-Gunma Substation	Minami-Iwaki Switching Station - Higashi-Gunma Substation
Length	44.4km	195.4km
Voltage and Number of Circuits	1MV design 2 circuits	1MV design 2 circuits
Power Lines	ACSR 610mm ² , 810mm ² × 8 conductors Low-noise ACSR 960mm ² × 8 conductors	ACSR 610mm ² , 810mm ² × 8 conductors Low-noise ACSR 940mm ² , 960mm ² × 8 conductors
Pylons	Number: 70 Height: 115m average	Number: 335 Height: 119m average
Start of Construction	September 1992	November 1995
Start of Operations	Line 2: April 1999 Line 1: June 1999	Line 2: July 1999 Line 1: October 1999

(2) Substation Facilities

(as of the end of FY2011)

At the End of FY		1951	1955	1965	1975	1985	1995	2000	2002	2003	2004	2005	2006	2007	2008	2009	2010	2011	Total of 10 EP Co. 2010	
Number of Locations		398	371	539	877	1,178	1,433 (476)	1,542 (505)	1,565 (511)	1,572 (514)	1,573 (514)	1,577 (522)	1,583 (524)	1,587 (526)	1,588 (525)	1,591 (527)	1,592 (527)	1,588 (521)	6,686	
Output (million kVA)		4.86	6.33	25.11	79.77	* 300 154.58	* 600 223.98 (54.38)	* 600 250.95 (61.82)	* 600 257.35 (61.98)	* 600 256.57 (62.02)	* 600 256.96 (62.20)	* 600 259.35 (62.42)	* 600 263.28 (63.33)	* 600 265.14 (63.24)	* 600 264.79 (62.89)	* 600 265.76 (63.03)	* 600 267.24 (63.15)	* 600 266.08 (63.30)	* 4,000 810.92	
Inclusive of those facilities for 275kV	Number of Locations	-	-	7	26	48	62 (18)	70 (20)	71 (20)	71 (20)	71 (20)	71 (20)	73 (20)	74 (20)	74 (20)	74 (20)	74 (20)	74 (20)	74 (20)	333
	Output (million kVA)	-	-	0.47	33.54	* 300 83.27	* 600 124.17 (20.60)	* 600 141.99 (24.58)	* 600 147.31 (24.58)	* 600 146.28 (24.58)	* 600 146.43 (24.73)	* 600 148.66 (24.88)	* 600 151.49 (25.63)	* 600 153.44 (25.63)	* 600 153.44 (25.63)	* 600 153.44 (25.63)	* 600 154.44 (25.63)	* 600 154.24 (25.63)	* 600 152.97 (25.63)	* 4,000 44.205

- Notes:
1. Figures marked with asterisks (*) are those for frequency conversion equipment as expressed in MW units. (Figures in total of 10 electric power companies include connection and conversion facilities.)
 2. Figures in parentheses are for facilities in Tokyo.
 3. "Inclusive of those facilities for 275 kV" figures for the 10 electric power companies are calculated on the basis of 187 kV.
 4. Figures for the 10 electric power companies are those for FY2010.

(3) Distribution Facilities

a. Number of Supports and Transformers for Distribution Facilities

(Unit : pieces)

	Pylons	Concrete Poles	Steel Poles	Wooden Poles	Total	Transformers
TEPCO	63	5,732,613	86,937	14,366	5,833,979	2,427,201 (2,156,424)
10 EP Co.	1,147	20,613,526	608,294	155,962	21,378,929	10,273,466 (9,938,234)

(as of the end of FY2011)

Note: Figures in parentheses are pole-mounted transformers.

Source: "Statistics of Electric Power Industry"

b. Underground Distribution Line Installation Rate

(as of the end of FY2011)

At the End of FY	TEPCO			In Tokyo's 23 Wards			Central Tokyo (Chuo-, Chiyoda- and part of Minato-ward)			Total of 10 EP Co.		
	*1	*2	*3	*1	*2	*3	*1	*2	*3	*1	*2	*3
1965	128,253	3,941	3.0	14,676	2,952	16.7	-	-	-	592,862	5,793	1.0
1970	165,009	6,141	3.6	17,208	3,899	18.5	-	-	-	725,459	9,416	1.3
1975	198,734	7,934	3.8	18,453	4,701	20.3	-	-	-	832,127	14,358	1.7
1980	231,393	10,701	4.4	18,561	6,015	24.5	549	1,961	78.1	919,340	19,841	2.1
1985	253,444	13,237	5.0	18,915	7,160	27.5	573	2,109	78.6	987,182	25,208	2.5
1990	278,794	19,902	6.7	19,025	10,368	35.3	847	3,249	79.3	1,071,994	38,374	3.5
1995	298,436	25,850	8.0	19,170	13,013	40.4	763	3,865	83.5	1,144,958	50,764	4.2
1998	308,563	28,600	8.5	19,221	13,943	42.0	724	3,996	84.7	1,183,776	57,376	4.6
1999	311,419	29,492	8.7	19,226	14,216	42.5	717	4,034	84.9	1,194,784	59,359	4.7
2000	314,077	30,294	8.8	19,210	14,487	43.0	706	4,068	85.2	1,204,118	61,077	4.8
2001	316,385	31,070	8.9	19,197	14,680	43.3	699	4,102	85.4	1,212,142	62,522	4.9
2002	318,322	31,609	9.0	19,190	14,687	43.4	694	4,085	85.5	1,282,821	63,949	5.0
2003	320,145	32,299	9.2	19,188	14,961	43.8	686	4,058	85.5	1,225,077	65,423	5.1
2004	321,935	32,830	9.3	19,187	15,113	44.1	680	4,110	85.8	1,231,180	66,704	5.1
2005	324,062	33,418	9.3	19,174	15,305	44.4	664	4,166	86.3	1,247,655	68,088	5.2
2006	326,123	34,028	9.4	19,167	15,498	44.7	658	4,207	86.5	1,254,011	69,338	5.2
2007	327,928	34,567	9.5	19,160	15,703	45.0	654	4,254	86.7	1,260,137	70,627	5.3
2008	329,581	35,061	9.6	19,142	15,840	45.3	651	4,260	86.7	1,265,471	71,943	5.4
2009	330,917	35,487	9.7	19,128	16,004	45.6	643	4,278	86.9	1,270,352	73,104	5.4
2010	332,120	35,887	9.8	19,097	16,147	45.8	637	4,302	87.1	1,267,640	74,118	5.5
2011	333,162	36,315	9.8	19,059	16,263	46.0	630	4,322	87.3	1,268,126	75,941	5.6

*1 = Overhead lines (km) *2 = Underground lines (km) *3 = Underground installation rate (%)

- Notes:
- Underground installation rate = $\frac{\text{Total circuit length of underground lines}}{\text{Total route length of overhead lines} + \text{Total circuit length of underground lines}} \times 100 (\%)$
 - Data for central Tokyo for FY1989 and thereafter are based on those for the entire wards of Chuo, Chiyoda and Minato.
 - In the case of TEPCO, the total length of underground cables for FY1990 and thereafter includes that of transmission cables belonging to the Distribution Dept.
 - Figures are given for a total of 9 power companies (except Okinawa Electric Power Company) before FY1985.

3. Forced Outages

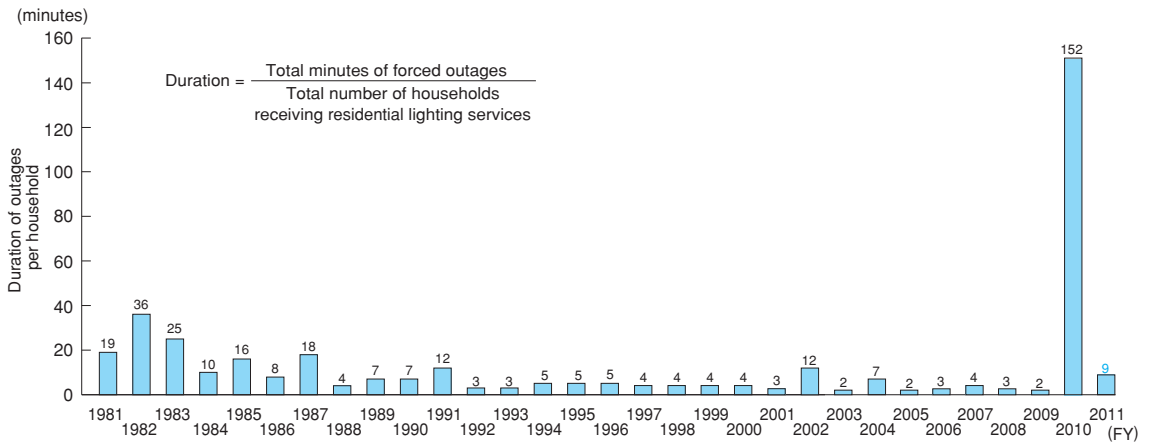
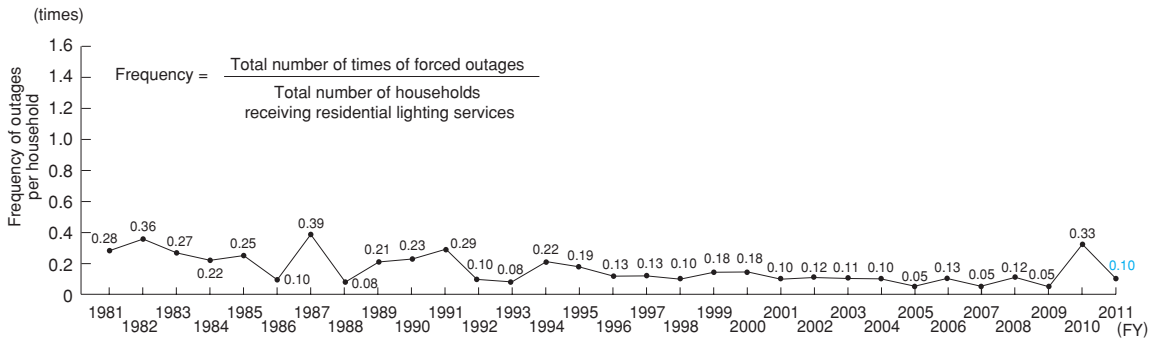

Note: Forced outages caused by disasters and planned construction are excluded.

<Reference> Changes in Single-Phase Three-Wire Facility Installation Rate for Lighting Service (TEPCO)

(as of the end of FY2011)

FY	2001	2002	2003	2004	2005	2006	2007	2008	2009	2010	2011
Single-phase Three-wire Facility Installation Rate (%)	57.8	58.5	60.0	61.4	63.4	64.5	65.6	66.4	67.2	67.9	68.7

Note: Contracts for Electric water heaters are excluded.

V. Fuels

1. Fuel Consumption (Thermal power)

FY	1970	1975	1980	1985	1990	1995	2000	2005	2006	2007	2008	2009	2010	2011	Total of 10 EP Co.
															2011
Coal (million tons)	2.11 (8)	0	0	0.34 (1)	0.38 (1)	0.36 (0)	0 (0)	3.42 (7)	3.18 (7)	3.46 (6)	3.10 (5)	3.54 (7)	3.02 (6)	3.22 (5)	49.16 (27)
Heavy Oil (million kl)	10.85 (72)	6.65 (36)	6.01 (30)	5.25 (23)	7.05 (24)	5.66 (19)	2.79 (10)	4.87 (15)	2.85 (9)	6.79 (17)	6.03 (16)	3.05 (9)	3.12 (9)	5.56 (13)	11.82 (9)
Crude Oil (million kl)	2.06 (13)	6.64 (33)	3.02 (14)	3.17 (14)	5.00 (16)	3.64 (12)	2.74 (9)	2.56 (8)	1.19 (4)	3.20 (8)	2.60 (7)	1.32 (4)	1.63 (5)	2.52 (6)	11.57 (9)
Naphtha (million kl)	0	1.05 (5)	0.65 (3)	0.01 (0)	0 (0)	0 (0)	0 (0)	0 (0)	0 (0)	0 (0)	0 (0)	0 (0)	0 (0)	0 (0)	0 (0)
NGL (million kl)	0	0.33 (2)	1.46 (6)	0.06 (1)	0.10 (0)	0.16 (1)	0.04 (0)	0.03 (0)	0.02 (0)	0.02 (0)	0 (0)	0.04 (0)	0.01 (0)	0 (0)	0 (0)
LNG - LPG (million ton)	0.72 (7)	3.27 (24)	6.99 (47)	10.05 (60)	12.99 (58)	14.57 (66)	16.86 (79)	16.42 (66)	17.10 (75)	20.19 (66)	19.46 (68)	18.71 (76)	19.79 (76)	23.72 (73)	53.82 (55)
Natural Gas (billion Nm³)	0	0	0	0.30 (1)	0.23 (1)	0.21 (1)	0.21 (1)	0.16 (0)	0.15 (0)	0.02 (0)	0 (0)	0 (0)	0 (0)	0 (0)	0.26 (0)
City Gas (billion Nm³)	-	-	-	-	-	-	0.01 (0)	1.21 (4)	1.23 (5)	1.18 (3)	1.23 (4)	1.20 (4)	1.27 (4)	1.34 (3)	1.34 (0)
Total (million kl: heavy oil equivalent)	15.01	18.54	20.00	22.39	29.77	29.24	28.24	33.03	30.46	40.36	37.84	33.03	34.44	43.09	127.76

Note: Figures in parentheses represent the percentage composition. Based on unit calorific values for the fiscal years, data for each fuel are given in heavy oil equivalents.

Source: "An Overview of Power Supply and Demand," etc.

2. Crude Oil / Heavy Oil

(1) Crude Oil Purchase and Consumption

a. TEPCO's Crude Oil Purchase and Consumption

(Unit: 1,000 kl)

FY	2002	2003	2004	2005	2006	2007	2008	2009	2010	2011
Indonesia	1,917	2,518	1,801	1,788	1,081	1,846	1,642	901	1,355	1,480
Brunei	-	71	65	205	63	142	-	-	-	-
China	390	678	-	-	-	-	-	-	-	-
Vietnam	-	-	-	-	60	123	157	45	-	-
Australia	331	426	267	289	140	335	227	141	150	306
Sudan	55	50	68	305	118	744	569	157	70	566
Gabon	-	-	-	-	-	-	-	-	-	120
Other	-	-	-	-	96	108	139	79	38	64
Total Purchase	2,693	3,743	2,201	2,587	1,558	3,298	2,734	1,323	1,613	2,536
Total Consumption	3,011	3,825	2,166	2,560	1,190	3,196	2,596	1,323	1,630	2,514

b. Total Crude Oil Purchase and Consumption for 10 Electric Power Companies

(Unit: 1,000 kl)

FY	2002	2003	2004	2005	2006	2007	2008	2009	2010	2011
Indonesia	3,667	3,373	4,030	4,945	3,534	-	-	-	-	-
Brunei	-	71	65	205	63	-	-	-	-	-
Vietnam	240	102	77	578	510	-	-	-	-	-
Australia	406	463	309	419	170	391	-	-	-	-
Gabon	50	-	-	95	23	175	-	-	-	-
China	1,123	1,442	82	60	-	-	-	-	-	-
Sudan	94	73	721	1,156	1,532	2,212	-	-	-	-
Russia	-	-	27	108	54	223	-	-	-	-
Total Purchase	5,770	5,669	5,712	7,960	6,847	11,347	8,416	3,609	4,689	11,573
Total Consumption	6,577	5,809	6,050	7,800	6,120	11,301	7,979	3,643	4,759	11,569

Note: The figures of oil purchase by country are not disclosed since FY2008.

Source: "Overview of Power Supply and Demand," etc.

(2) Heavy Oil Purchase and Consumption

a. TEPCO's Heavy Oil Purchase and Consumption

(Unit: 1,000 kl)

FY	2002	2003	2004	2005	2006	2007	2008	2009	2010	2011
Purchase	3,928	5,787	4,059	4,962	2,931	6,718	5,975	3,055	3,002	5,774
Consumption	4,076	5,839	4,123	4,867	2,854	6,792	6,029	3,046	3,123	5,562

b. Total Heavy Oil Purchase and Consumption for 10 Electric Power Companies

(Unit: 1,000 kl)

FY	2002	2003	2004	2005	2006	2007	2008	2009	2010	2011
Purchase	8,184	9,452	7,955	9,744	7,638	11,892	10,477	5,564	6,130	12,341
Consumption	8,449	9,559	8,313	9,715	7,351	11,931	10,279	5,583	6,299	11,824

Source: "Overview of Power Supply and Demand," etc.

(3) Yearly Changes in Crude Oil CIF Pricing

FY	1976	1977	1978	1979	1980	1981	1982	1983	1984
CIF Price (US\$/barrel)	12.69	13.69	13.89	23.07	34.61	36.94	34.07	29.66	29.14
FY	1985	1986	1987	1988	1989	1990	1991	1992	1993
CIF Price (US\$/barrel)	27.29	13.81	18.15	14.79	17.86	23.34	18.89	19.29	16.73
FY	1994	1995	1996	1997	1998	1999	2000	2001	2002
CIF Price (US\$/barrel)	17.32	18.27	21.63	18.82	12.76	20.92	28.37	23.84	27.42
FY	2003	2004	2005	2006	2007	2008	2009	2010	2011
CIF Price (US\$/barrel)	29.43	38.77	55.81	63.50	78.73	90.52	69.40	84.16	114.18

Note: CIF (Cost, Insurance and Freight) price refers to the import price including all expenses (such as freight, fares and insurance premiums) after shipment. It may well be the delivery price to Japanese ports.

<Reference> Monthly Changes in Crude Oil Pricing

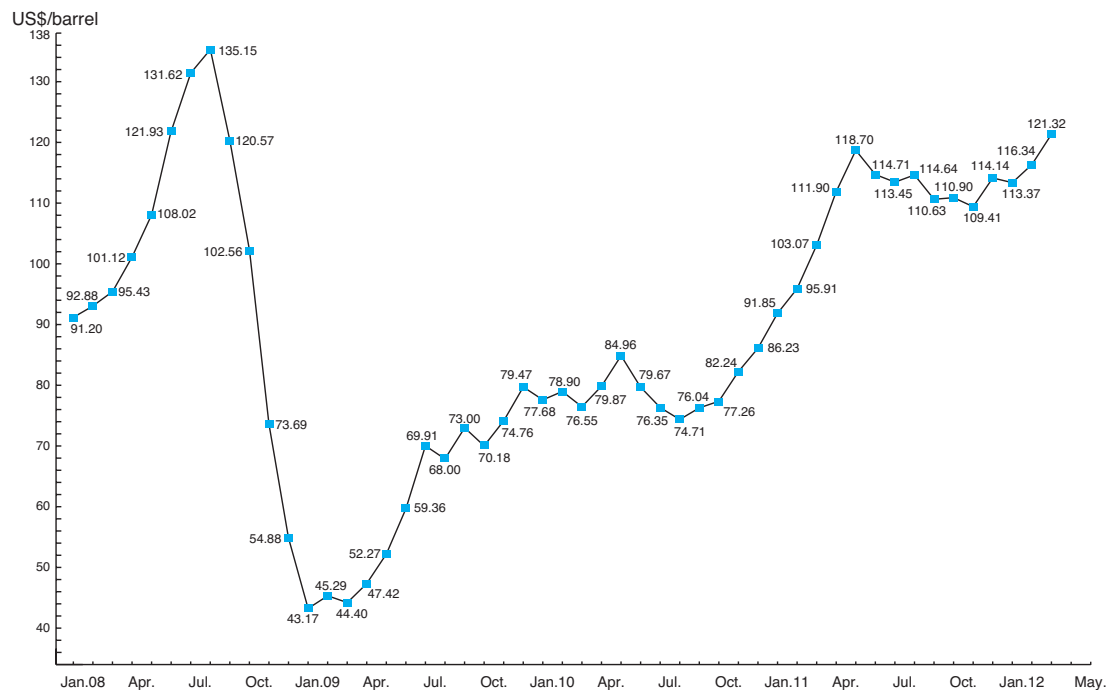

Note: Final figures through December 2011, preliminary figures for January to February 2012. New early report values for March 2012.

Source: "Trade Statistics Prices," Ministry of Finance.

3. LNG

(1) LNG Purchase and Consumption

a. TEPCO's LNG Purchase and Consumption

(Unit: 1,000 t)

FY	2000	2001	2002	2003	2004	2005	2006	2007	2008	2009	2010	2011
Alaska	972	977	931	933	908	937	846	582	523	422	418	-
Brunei	3,939	4,033	4,042	4,302	4,318	4,113	4,180	4,440	4,074	4,122	4,122	4,015
Abu Dhabi	4,803	4,913	4,634	4,893	4,868	4,878	4,899	5,119	4,942	4,870	4,761	4,914
Malaysia	4,858	4,961	5,127	5,171	5,162	5,037	4,386	4,690	4,091	3,862	3,874	3,867
Indonesia	491	328	708	380	326	108	56	161	107	109	166	54
Australia	1,163	759	893	1,205	562	380	503	484	964	281	352	239
Qatar	240	180	240	237	180	58	58	120	118	238	292	178
Darwin	-	-	-	-	-	61	1,816	2,061	2,217	2,388	2,131	1,950
Qalhat	-	-	-	-	-	-	248	754	685	757	561	689
Sakhalin	-	-	-	-	-	-	-	-	-	1,807	2,069	2,119
Spot Contract	-	-	237	2,029	529	1,026	478	2,006	2,342	723	2,042	6,063
Total Purchase	16,466	16,151	16,812	19,150	16,853	16,598	17,470	20,417	20,063	19,579	20,788	24,088
Total Consumption	16,598	15,929	16,959	19,118	16,652	16,044	16,804	19,870	18,972	18,507	19,462	22,884

Note: Japan's total LNG purchase amount to approx. 83.18 million tons (in FY2011). The world's total amount of LNG traded comes to nearly 240.80 million tons (in 2011).

b. Total LNG Purchase and Consumption for Electric Power Suppliers

(Unit: 1,000 t)

FY	2000	2001	2002	2003	2004	2005	2006	2007	2008	2009	2010	2011
U.S.A.	972	977	931	933	908	937	846	582	-	-	-	-
Brunei	3,939	4,033	4,042	4,302	4,318	4,113	4,180	4,440	-	-	-	-
Abu Dhabi	4,803	4,913	4,634	5,255	5,047	5,432	5,383	5,506	-	-	-	-
Indonesia	12,317	11,044	11,772	10,923	9,423	7,749	7,999	7,617	-	-	-	-
Malaysia	5,959	6,341	5,814	6,544	6,537	6,481	6,051	6,323	-	-	-	-
Australia	5,383	5,320	4,910	4,857	4,827	5,345	6,812	6,190	-	-	-	-
Qatar	5,398	5,544	5,789	5,644	5,660	5,319	6,044	5,956	-	-	-	-
Oman	-	123	184	794	488	391	1,461	2,082	-	-	-	-
Trinidad and Tobago	-	-	-	56	55	56	54	219	-	-	-	-
Nigeria	-	-	-	-	58	-	165	717	-	-	-	-
Algeria	-	-	-	-	-	-	184	305	-	-	-	-
Total Purchase	38,771	38,295	38,076	39,308	37,321	35,823	39,179	40,593	42,880	42,222	43,935	55,422
Total Consumption	38,662	38,174	37,917	39,062	37,169	34,640	38,165	42,075	41,006	40,641	41,743	52,869

- Notes:
1. LNG purchase and consumption results by country for 10 general electric power suppliers and Tobata Co-operative Thermal Power Company, Inc. until FY2009. Only those that can be identified by country are listed.
 2. The figures of LNG purchase by country are not disclosed since FY2008.

Source: "Overview of Power Supply and Demand," etc.

(2) TEPCO's LNG Contract Summary (long-term contracts only)

	Brunei	Das (U.A.E.)	Satu (Malaysia)	Australia	Qatar
Sellers	○Brunei LNG	○Abu Dhabi Gas Liquefaction (ADGAS)	○Malaysia LNG	○BHP Billiton Petroleum (NWS) ○BP Developments (Australia) ○Chevron Australia ○Japan-Australia LNG (MIMI) ○Shell Development (Australia) ○Woodside Energy	○Qatar Liquefied Gas Company Limited
Contract Quantity (for plateau year)	4.03 million tons [Extension 2.03 million tons] *	LNG: 4.30 million tons LPG: 0.70 million tons	Max: 4.80 million tons Ex-ship: 3.60 million tons FOB: 1.20 million tons (including short-term: 0.70 million tons)	0.30 million tons	①0.20 million tons ②1.00 million tons
Project Contract Period (from acceptance of the first shipment to expiration)	20 years + 20 years (Jan. 1973 - Mar. 2013) [Extension 10 years Apr. 2013 - Mar. 2023] *	17 years + 25 years (May 1977 - Mar. 2019)	20 years + 15 years (Feb. 1983 - Mar. 2018)	8 years (Apr. 2009 - Mar. 2017)	①25 years (Jun. 1999 - Dec. 2021) ②10 years (Aug. 2012 - Dec. 2021)
Receiving Terminals (TEPCO)	Minami Yokohama, Higashi Ohgishima, Sodegaura, Futtsu	LNG: Higashi Ohgishima, Futtsu LPG: Anegasaki	Minami Yokohama, Higashi Ohgishima, Sodegaura, Futtsu	Higashi Ohgishima, Sodegaura, Futtsu	Higashi Ohgishima, Futtsu
Power Stations	[Minami Yokohama, Higashi Ohgishima, Yokohama, Kawasaki, Sodegaura, Anegasaki, Goi, Futtsu, Chiba]	[Higashi Ohgishima, Yokohama, Kawasaki, Anegasaki, Goi, Futtsu, Chiba]	[Minami Yokohama, Higashi Ohgishima, Yokohama, Kawasaki, Sodegaura, Anegasaki, Goi, Futtsu, Chiba]	[Higashi Ohgishima, Yokohama, Kawasaki, Sodegaura, Anegasaki, Goi, Futtsu, Chiba]	[Higashi Ohgishima, Yokohama, Kawasaki, Anegasaki, Goi, Futtsu, Chiba]

Note: *Agreed contract quantity and period based on the Heads of Agreement for extension contract.

(as of the end of June 2012)

Darwin (Australia)	Qalhat (Oman)	Sakhalin II (Russia)	Papua New Guinea	Wheatstone (Australia)	Ichthys (Australia)
○Darwin LNG	○CELT INC.	○Sakhalin Energy Investment	○Papua New Guinea Liquefied Natural Gas Global Company LDC	①○Chevron Australia Pty Ltd ○Chevron (TAPL) Pty Ltd ○Apache Julimar Pty Ltd ○Kutpec Australia (Julimar) Pty Ltd ②○PE Wheatstone Pty Ltd ③○Chevron Australia Pty Ltd ○Chevron (TAPL) Pty Ltd	○Ichthys LNG Pty Ltd
2.00 million tons	Max 0.80 million tons (joint purchase with Mitsubishi Corporation)	1.50 million tons (basic figures)	Approx. 1.80 million tons	①Approx. 3.10 million tons ②Approx. 0.70 million tons ③Approx. 0.40 million tons	1.05 million tons
17 years (Mar. 2006 - Dec. 2022)	15 years (Apr. 2006 - Dec. 2020)	22 years (Apr. 2009 - Mar. 2029) (beginning of supply : at the end of March 2009)	20 years Beginning of supply (Planned) (late 2013 - 2014)	Max 20 years Beginning of supply (Planned) (2017)	15 years (2017 - 2031)
Higashi Ohgishima, Sodegaura, Futtsu	Higashi Ohgishima, Futtsu	Higashi Ohgishima, Sodegaura, Futtsu			
[Higashi Ohgishima, Yokohama, Kawasaki, Sodegaura, Anegasaki, Goi, Futtsu, Chiba]	[Higashi Ohgishima, Yokohama, Kawasaki, Anegasaki, Goi, Futtsu, Chiba]	[Higashi Ohgishima, Yokohama, Kawasaki, Sodegaura, Anegasaki, Goi, Futtsu, Chiba]			

4. Coal

(1) TEPCO's Coal Purchase and Consumption

(Unit: 1,000 t)

FY	2002	2003	2004	2005	2006	2007	2008	2009	2010	2011
Australia	441	1,762	3,213	3,258	2,964	3,498	3,054	3,384	2,915	3,310
U.S.A.	-	-	-	-	-	-	-	40	-	-
South Africa	-	-	-	-	-	-	-	-	-	-
China	-	-	-	-	-	-	35	-	-	-
Canada	-	-	-	-	73	83	45	-	87	-
Indonesia	-	244	31	154	212	-	-	-	48	-
Russia	-	-	-	-	-	-	-	-	-	-
Total Purchase	441	2,006	3,244	3,412	3,249	3,581	3,134	3,424	3,050	3,310
Total Consumption	304	1,887	3,372	3,417	3,176	3,463	3,099	3,537	3,017	3,222

(2) Total Coal Purchase and Consumption for 10 Electric Power Companies

(Unit: 1,000 t)

FY	2000	2001	2002	2003	2004	2005	2006	2007	2008	2009	2010	2011
Total Purchase	34,034	39,047	40,870	43,950	48,549	50,450	50,595	53,040	52,389	46,230	52,307	49,154
Total Consumption	34,367	37,429	41,350	44,557	48,229	50,565	50,605	52,701	50,776	47,855	51,018	49,160

Source: "Electric Power Supply and Demand Summary," etc.

MEMO

VI. Nuclear Power

1. Nuclear Power Generation

(1) General Data on Nuclear Power Plants in Operation

	Fukushima Daiichi Nuclear Power Station						Fukushima Daini		
	Unit 1	Unit 2	Unit 3	Unit 4	Unit 5	Unit 6	Unit 1	Unit 2	
Output (MW)	460	784	784	784	784	1,100	1,100	1,100	
Decided on by the Council (Number)	Dec. 25, '68* (49)	Dec. 22, '67 (47)	May 23, '69 (50)	Jun. 30, '71 (55)	Feb. 26, '71 (54)	Dec. 17, '71 (57)	Jun. 7, '72 (59)	Mar. 17, '75 (66)	
Application for License to Install [Section 23 of the Nuclear Regulation Law]	Nov. 19, '68*	Sep. 18, '67	Jul. 1, '69	Aug. 5, '71	Feb. 22, '71	Dec. 21, '71	Aug. 28, '72	Dec. 21, '76	
Date of License Granted	Apr. 7, '69*	Mar. 29, '68	Jan. 23, '70	Jan. 13, '72	Sep. 23, '71	Dec. 12, '72	Apr. 30, '74	Jun. 26, '78	
Start of Construction Work (construction project authorized) [Electricity Enterprises Law Article 47]	Sep. 29, '67	May 27, '69	Oct. 17, '70	May 8, '72	Dec. 22, '71	Mar. 16, '73	Aug. 21, '75	Jan. 23, '79	
(Start of Foundation Excavation)	Apr. 1, '67	Jan. 18, '69	Aug. 25, '70	Sep. 12, '72	Dec. 22, '71	May 18, '73	Nov. 1, '75	Feb. 28, '79	
Start of Commercial Operation	Mar. 26, '71	Jul. 18, '74	Mar. 27, '76	Oct. 12, '78	Apr. 18, '78	Oct. 24, '79	Apr. 20, '82	Feb. 3, '84	
Number of Fuel Assemblies Loaded (Tons-U)	69	94	94	94	94	132	132	132	
(Pieces)	400	548	548	548	548	764	764	764	
Type of Reactor Container	Mark I	Mark I	Mark I	Mark I	Mark I	Mark II	Mark II	Mark II Advanced	
Domestic Content (%)	56	53	91	91	93	63	98	99	
Main Contractor	G E	G E Toshiba	Toshiba	Hitachi	Toshiba	G E Toshiba	Toshiba	Hitachi	
Location	Ohkuma-machi, Futaba-gun, Fukushima Pref.				Futaba-machi, Futaba-gun, Fukushima Pref.		Naraha-machi, Futaba-gun, Fukushima Pref.		

- Notes:
- Figures for fuels loaded indicate the weight (in tons-U) of uranium fuel in the upper row and the number (in pieces) of fuel assemblies in the lower row.
 - For Fukushima Daiichi Nuclear Power Station Unit 1, the dates (*) given indicate those after a change in capacity (from 400 MW to 460 MW).
 - On April 19, 2012, following the notification of decommissioning submitted on March 30, 2012 in accordance with Article 9 of the Electric Utilities Industry Law, Units 1-4 at Fukushima Daiichi Nuclear Power Station were decommissioned.

(as of the end of March 2012)

Nuclear Power Station			Kashiwazaki-Kariwa Nuclear Power Station							
	Unit 3	Unit 4	Unit 1	Unit 2	Unit 3	Unit 4	Unit 5	Unit 6	Unit 7	
	1,100 Mar. 15, '77 (71)	1,100 Jul. 14, '78 (75)	1,100 Jul. 4, '74 (65)	1,100 Mar. 26, '81 (84)	1,100 Mar. 27, '85 (99)	1,100 Mar. 27, '85 (99)	1,100 Mar. 26, '81 (84)	1,356 Mar. 18, '88 (108)	1,356 Mar. 18, '88 (108)	
	Aug. 16, '78 Aug. 4, '80	Aug. 16, '78 Aug. 4, '80	Mar. 20, '75 Sep. 1, '77	May 11, '81 May 6, '83	Apr. 11, '85 Apr. 9, '87	Apr. 11, '85 Apr. 9, '87	May 11, '81 May 6, '83	May 23, '88 May 15, '91	May 23, '88 May 15, '91	
	Nov. 10, '80 Dec. 1, '80	Nov. 10, '80 Dec. 1, '80	Nov. 4, '78 Dec. 1, '78	Aug. 22, '83 Oct. 26, '83	Jun. 16, '87 Jul. 1, '87	Jun. 16, '87 Feb. 5, '88	Aug. 22, '83 Oct. 26, '83	Aug. 23, '91 Sep. 17, '91	Aug. 23, '91 Feb. 3, '92	
	Jun. 21, '85 132 764	Aug. 25, '87 132 764	Sep. 18, '85 132 764	Sep. 28, '90 132 764	Aug. 11, '93 132 764	Aug. 11, '94 132 764	Apr. 10, '90 132 764	Nov. 7, '96 150 872	Jul. 2 '97 150 872	
	Mark II Advanced 99	Mark II Advanced 99	Mark II 99	Mark II Advanced 99	Mark II Advanced 99	Mark II Advanced 99	Mark II Advanced 99	Made of reinforced concrete 89	Made of reinforced concrete 89	
	Toshiba	Hitachi	Toshiba	Toshiba	Toshiba	Hitachi	Hitachi	Toshiba Hitachi G E	Hitachi Toshiba G E	
	Tomioka-machi, Futaba-gun, Fukushima Pref.		Kashiwazaki-shi, Niigata Pref.				Kashiwazaki-shi and Kariwa-mura, Niigata Pref.			

(2) Nuclear Power Plant Capacity Factor Trend

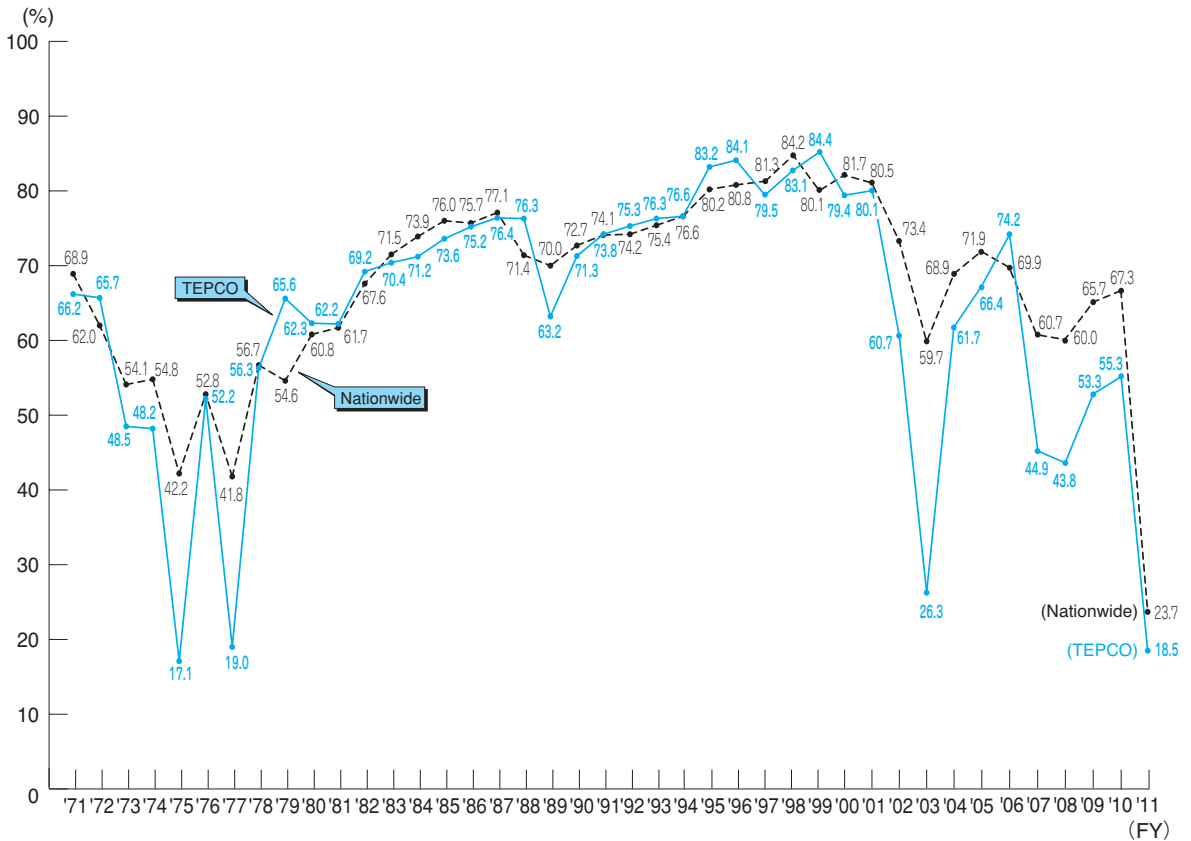

- Notes:
1. Figures decreased in FY2002 and FY2003 due to the suspension of a large number of nuclear plants for inspection and repair.
 2. The capacity utilization rates do not include preoperation tests. The figures do not necessarily add up to the total shown because fractions were rounded off.

3. Capacity factor =
$$\frac{\text{Electricity generation}}{\text{Authorized capacity} \times \text{Number of calendar hours}} \times 100 (\%)$$

(3) Nuclear Power Plant Performance

(Unit: %)

Nuclear Plant Unit No.	Fukushima Daiichi						Fukushima Daini				Kashiwazaki-Kariwa							T E P C O	Remarks
	No 1	No 2	No 3	No 4	No 5	No 6	No 1	No 2	No 3	No 4	No 1	No 2	No 3	No 4	No 5	No 6	No 7		
FY 1971	66.2	-	-	-	-	-	-	-	-	-	-	-	-	-	-	-	-	66.2	68.9
1972	65.7	-	-	-	-	-	-	-	-	-	-	-	-	-	-	-	-	65.7	62.0
1973	48.5	-	-	-	-	-	-	-	-	-	-	-	-	-	-	-	-	48.5	54.1
1974	26.2	66.5	-	-	-	-	-	-	-	-	-	-	-	-	-	-	-	48.2	54.8
1975	16.3	16.5	99.9	-	-	-	-	-	-	-	-	-	-	-	-	-	-	17.1	42.2
1976	24.8	47.7	72.8	-	-	-	-	-	-	-	-	-	-	-	-	-	-	52.2	52.8
1977	6.0	3.9	41.8	-	-	-	-	-	-	-	-	-	-	-	-	-	-	19.0	41.8
1978	40.4	54.6	43.5	82.9	68.3	-	-	-	-	-	-	-	-	-	-	-	-	56.3	56.7
1979	58.3	65.7	50.8	59.5	70.9	98.0	-	-	-	-	-	-	-	-	-	-	-	65.6	54.6
1980	55.0	45.2	68.8	68.2	68.7	64.1	-	-	-	-	-	-	-	-	-	-	-	62.3	60.8
1981	29.7	46.6	76.1	70.8	69.6	65.5	-	-	-	-	-	-	-	-	-	-	-	62.2	61.7
1982	53.8	80.0	40.6	63.2	62.0	70.3	98.1	-	-	-	-	-	-	-	-	-	-	69.2	67.6
1983	63.4	63.1	55.0	91.1	56.9	81.1	69.0	100.0	-	-	-	-	-	-	-	-	-	70.4	71.5
1984	92.1	56.4	66.7	71.3	81.9	63.4	68.3	79.5	-	-	-	-	-	-	-	-	-	71.2	73.9
1985	46.7	53.7	77.4	64.9	75.8	58.3	74.4	84.2	96.4	-	99.7	-	-	-	-	-	-	73.6	76.0
1986	65.9	85.1	85.7	56.3	60.6	67.6	90.1	84.3	74.1	-	72.9	-	-	-	-	-	-	75.2	75.7
1987	61.7	71.3	57.1	79.6	53.9	88.4	82.4	74.4	77.1	99.8	82.6	-	-	-	-	-	-	76.4	77.1
1988	97.1	62.3	63.2	93.9	90.6	71.1	65.6	77.6	71.1	75.3	84.3	-	-	-	-	-	-	76.3	71.4
1989	13.7	80.2	93.7	69.8	81.4	39.2	66.5	87.2	0.0	77.8	78.0	-	-	-	-	-	-	63.2	70.0
1990	64.3	66.1	50.7	62.5	60.1	90.9	65.8	73.9	33.8	96.4	62.9	95.2	-	-	99.8	-	-	71.3	72.7
1991	31.1	45.8	60.1	88.6	77.0	76.6	89.4	74.3	67.0	79.1	90.3	74.8	-	-	77.0	-	-	74.1	73.8
1992	71.6	62.3	89.5	71.8	87.7	62.5	70.9	62.4	97.9	61.3	84.9	81.5	-	-	75.4	-	-	75.3	74.2
1993	52.7	84.4	74.0	59.5	64.3	57.1	61.1	97.6	74.3	83.0	74.6	94.7	99.8	-	78.7	-	-	76.3	75.4
1994	100.0	34.9	61.2	90.1	64.4	99.9	79.6	76.1	49.8	89.4	76.1	79.1	79.1	63.0	98.7	-	-	76.6	76.6
1995	79.4	76.0	67.8	92.3	80.4	73.8	100.0	73.2	90.9	84.0	81.9	83.5	85.5	90.5	81.5	-	-	83.2	80.2
1996	45.1	88.4	97.2	74.4	96.9	65.9	73.0	87.7	96.1	73.6	91.7	74.3	100.0	87.1	85.6	100.0	-	84.1	80.8
1997	99.7	81.9	15.0	50.7	73.0	86.6	66.7	92.1	81.1	87.2	74.2	100.0	86.8	81.5	76.3	83.0	100.0	79.5	81.3
1998	84.0	36.0	64.6	95.8	81.5	81.3	75.9	80.2	89.7	100.0	78.8	88.4	73.1	88.1	100.0	93.5	84.5	83.1	84.2
1999	69.3	72.8	66.8	92.9	68.4	85.6	100.0	88.7	75.2	87.8	87.6	89.2	83.4	100.0	84.3	90.1	73.9	84.4	80.1
2000	72.2	78.4	99.9	66.4	49.6	68.7	78.4	75.9	99.7	71.9	95.6	70.6	100.0	66.4	75.8	81.7	86.1	79.4	81.7
2001	37.5	69.0	85.5	88.3	89.5	95.2	74.8	92.2	31.6	86.3	74.1	99.1	75.7	69.2	88.3	80.7	99.0	80.1	80.5
2002	56.9	99.7	29.3	46.0	86.3	67.4	76.9	25.5	46.1	53.6	42.4	40.0	35.7	76.7	92.2	82.4	70.0	60.7	73.4
2003	0.0	0.0	62.5	2.4	55.0	25.0	57.5	0.0	6.9	0.0	0.0	0.0	0.0	69.1	0.0	91.3	45.9	26.3	59.7
2004	0.0	64.6	36.7	69.0	58.1	24.9	49.2	59.2	67.5	37.4	85.2	75.6	75.6	37.1	91.7	75.3	90.6	61.7	68.9
2005	47.4	63.9	89.7	30.5	67.1	72.8	86.4	66.0	28.9	58.0	19.5	69.3	85.9	100.8	74.4	71.2	78.4	66.4	71.9
2006	72.5	45.8	72.7	76.2	59.7	82.1	74.6	100.6	87.8	41.1	93.4	89.7	79.7	31.5	65.9	98.9	71.2	74.2	69.9
2007	40.8	91.7	65.5	86.3	73.1	62.8	75.1	52.4	76.7	76.7	9.2	6.5	29.5	29.6	0.0	7.3	29.9	44.9	60.7
2008	54.5	86.0	90.5	70.2	80.5	95.2	89.1	81.6	73.1	93.4	0.0	0.0	0.0	0.0	0.0	0.0	43.8	60.0	
2009	91.7	73.4	71.2	82.6	86.5	80.0	93.6	93.4	82.1	71.5	0.0	0.0	0.0	0.0	0.0	55.1	72.3	53.3	65.7
2010	51.5	67.9	68.1	66.5	63.8	38.5	66.6	77.3	94.7	72.8	82.6	0.0	0.0	0.0	33.9	77.6	78.5	55.3	67.3
2011	0.0	0.0	0.0	0.0	0.0	0.0	0.0	0.0	0.0	0.0	35.4	0.0	0.0	0.0	82.7	101.0	38.8	18.5	23.7

Notes: 1. Capacity factor = $\frac{\text{Electricity generation}}{\text{Authorized capacity} \times \text{Number of calendar hours}} \times 100 (\%)$

2. On April 19, 2012, following the notification of decommissioning submitted on March 30, 2012 in accordance with Article 9 of the Electric Utilities Industry Law, Units 1-4 at Fukushima Daiichi Nuclear Power Station were decommissioned.

(4) Problem Occurrence

Problems to be Reported in Accordance with the Electricity Utilities Industry Law and the Law on the Regulation of Nuclear Source Material, Nuclear Fuel Material and Reactors

		FY 2002	FY 2003	FY 2004	FY 2005	FY 2006	FY 2007	FY 2008	FY 2009	FY 2010	FY 2011	Total (FY 2002-2011)	Cumulative
Fukushima Daiichi	Unit 1	0	0	0	0	0	1	2	0	1*2	0	4	38
	Unit 2	0	0	1	2	1	0	0	0	0	0	4	29
	Unit 3	0	0	0	1	0	0	1	1	0	0	3	19
	Unit 4	0	0	0	0	2	0	0	0	0	0	2	9
	Unit 5	0	0	0	1	1	0	1	0	1	0	4	15
	Unit 6	0	0	0	1	0	0	0	0	0	0	1	13
	Subtotal	0	0	1	5	4	1	4	1	2	0	18	123
Fukushima Daini	Unit 1	0	0	0	0	1	0	0	0	1	0	2	14 (6)
	Unit 2	1	0	0	1	0	1	0	0	0	0	3	9
	Unit 3	0	0	0	0	0	0	1	0	0	1*3	2	9
	Unit 4	0	1	0	0	1	0	0	1	0	0	3	6
	Subtotal	1	1	0	1	2	1	1	1	1	1	10	38 (6)
Kashiwazaki-Kariwa	Unit 1	0	0	2	0	0	1*1	0	0	0	0	3	7
	Unit 2	0	0	0	0	0	0	0	0	0	0	0	4
	Unit 3	0	0	0	0	0	1	0	0	1	0	2	3
	Unit 4	0	0	0	0	0	0	0	0	0	0	0	4
	Unit 5	0	0	1	1	0	0	0	0	0	0	2	3
	Unit 6	0	0	0	0	0	2	1	0	0	0	3	7 (2)
	Unit 7	0	0	0	0	0	0	0	0	0	0	0	2 (1)
	Subtotal	0	0	3	1	0	4	1	0	1	0	10	30 (3)
Total	1	1	4	7	6	6	6	2	4	1	38	191 (9)	

- Notes: 1. The cumulative total indicates the number of problems that have occurred since each unit entered service.
 2. The figures in parentheses indicate the number of occurrences before entering service and are described separately.
 3. Unit 1 of each nuclear power plant includes common facilities. Common Facilities include incinerators, solid radioactive wastes storages and port facility, etc.

*1 The figure represents overflow stream occurred at the operating floors of Unit 1 to Unit 7 due to the Niigata Chuetsu-Oki Earthquake (July 16, 2007).

*2 As a representation of the events reported in FY2010 and FY2011, the series of troubles at Fukushima Daiichi and Daini Nuclear Power Stations that were triggered by the Tohoku-Chihou-Taiheiyou-Oki Earthquake (March 11, 2011) will be counted as one trouble incident that occurred at Fukushima Daiichi Nuclear Power Station Unit 1 in FY2010.

*3 The contamination due to leakage of nuclear fuel materials, etc. at the uncontrolled area of Unit 3-4 Service Buildings of Fukushima Daini Nuclear Power Station (March 27, 2012) will be counted as one trouble incident that occurred at Unit 3.

(5) Annual Production of Solid Radioactive Wastes

Contents	Unit	'91	'92	'93	'94	'95	'96	'97	'98	'99	'00	'01	'02	'03	'04	'05	'06	'07	'08	'09	'10	'11
Number of Drums	Fukushima Daiichi Number	6,101	5,686	8,579	5,493	3,429	4,545	4,295	4,879	6,579	8,916	13,994	12,972	19,689	17,651	20,169	17,979	16,694	16,626	16,938	*	0
	Fukushima Daini Number	2,546	2,096	1,698	5,936	914	1,046	1,510	867	660	730	1,353	3,281	3,390	3,956	4,760	2,871	3,259	2,802	2,471	2,397	71
	Kashiwazaki-Kariwa Number	656	720	874	925	645	914	1,324	995	669	808	862	761	980	2,114	4,127	3,474	691	2,083	4,224	3,387	3,141
Number of Other Stored Items	Total Number	9,303	8,512	11,151	12,354	4,988	6,505	7,129	6,741	7,908	10,454	16,209	17,014	24,059	23,931	29,055	24,324	20,644	21,011	23,633	*	3,212
	Number of equivalents to drums	12	0	68	0	0	812	2,074	1,045	240	1,472	594	2,646	146	746	0	150	0	0	0	0	0
	Number of equivalents to drums	0	0	0	0	0	0	0	0	0	0	0	0	0	0	0	0	0	0	0	0	0
Reduction of Number of Drums by Incineration	Total Number	7,573	9,009	8,456	8,997	7,704	9,190	8,289	8,078	6,065	7,878	11,556	12,347	16,481	15,691	10,374	12,448	11,484	12,629	10,607	*	0
	Fukushima Daiichi Number	144	252	328	7,173	0	58	594	163	221	18	1,102	4,607	4,161	3,101	1,900	1,794	1,257	1,021	1,285	1,472	0
	Kashiwazaki-Kariwa Number	478	549	0	0	0	0	0	0	107	124	140	24	50	0	18	13	27	53	56	40	2,066
Reduction of Number of Drums by Ship Out	Total Number	8,195	9,810	8,784	16,170	7,704	9,248	8,863	8,241	6,393	8,020	12,798	16,978	20,692	18,792	12,292	14,255	12,788	13,703	11,948	*	2,066
	Fukushima Daiichi Number	0	2,680	7,296	8,000	8,000	8,320	11,248	6,912	4,358	1,200	4,000	3,840	5,960	4,000	3,200	4,000	0	1,920	3,008	3,456	0
	Kashiwazaki-Kariwa Number	0	0	0	0	0	0	0	0	0	0	2,072	2,000	2,000	2,000	960	0	0	2,000	0	2,000	0
Cumulative Number of Stored Drums	Total Number	0	2,680	7,296	8,000	8,000	8,320	11,248	6,912	4,358	1,200	6,072	5,840	7,960	6,000	4,160	4,000	0	3,920	3,008	5,456	0
	Fukushima Daiichi Number	244,620	238,627	231,454	219,950	207,675	194,710	179,488	169,377	165,531	165,371	163,809	160,594	157,842	155,802	162,397	163,928	168,138	171,215	174,538	*	*
	Kashiwazaki-Kariwa Number	15,742	17,586	18,956	17,719	18,633	19,621	20,537	21,241	21,680	22,392	20,571	17,245	14,474	12,939	14,839	15,916	17,918	17,199	18,385	17,310	17,381
Cumulative Number of Other Stored Items	Total Number	2,547	2,718	3,592	4,517	5,162	6,076	7,400	8,395	8,957	9,641	10,363	11,100	12,030	14,144	18,253	21,714	22,378	24,408	28,576	31,923	32,988
	Number of equivalents to drums	162	162	230	230	230	1,042	3,116	4,161	4,401	5,873	6,467	9,113	9,259	10,005	10,005	10,155	10,155	10,155	10,155	*	*
	Number of equivalents to drums	0	0	0	0	0	0	0	0	0	0	0	0	0	0	0	0	0	0	0	0	0
Total	Number of equivalents to drums	162	162	230	230	230	1,042	3,116	4,161	4,401	5,873	6,467	9,113	9,259	10,005	10,005	10,155	10,155	10,155	10,155	*	*
	Number of equivalents to drums	0	0	0	0	0	0	0	0	0	0	0	0	0	0	0	0	0	0	0	0	0
	Number of equivalents to drums	162	162	230	230	230	1,042	3,116	4,161	4,401	5,873	6,467	9,113	9,259	10,005	10,005	10,155	10,155	10,155	10,155	*	*

- Notes:
1. Solid waste includes low-level radioactive waste from which water used in the plant has been evaporated and which has been condensed, and the waste has been packed into a drum and set in concrete, and low-level radioactive waste that has been packed inside a drum, for example filter material or paper or cloth used in plant work which has been compacted and incinerated.
 2. Reduction of number of drums by ship out means the number of drums sent to the Rokkasho Low Level Radioactive Waste Underground Disposal Center located at Rokkasho-mura in Aomori Prefecture.
 3. Storage capacity: Fukushima Daiichi, 284,500 drums; Fukushima Daini, 32,000 drums; Kashiwazaki-Kariwa, 45,000 drums (as of the end of FY2009)
 4. * refers to data still being summarized (delay due to earthquake).

<Reference> Units of Radioactivity and Radiation

(Conversion Table for International new unit system, SI, and former units)

	New Units	Definition	Former Units	Conversion Formula
Unit of Radioactivity: capability to give off radiation	Becquerel, Bq	The number of nuclei that disintegrate in one second, which is an indicator of radioactivity	Curie, Ci	$1\text{Ci} = 3.7 \times 10^{10} \text{ Bq}$
Units Concerning Radiation Dose	Absorbed Dose: quantity in which radiation absorbed	Gray, Gy	Radiation dose when one joule of energy is absorbed per each 1 kg	Roentgen absorbed dose, rad $1\text{rad} = 0.01\text{Gy}$
	Dose Equivalent: influence degree of radiation received by people	Sievert, Sv	Unit of gray multiplied by the relative biological effectiveness	Roentgen equivalent man, rem $1\text{rem} = 0.01 \text{ Sv}$

Relationship of units: 1/1000 of 1 sievert is equivalent to 1 millisievert (mSv).

Note: The former units, curie, rad and rem have been replaced since FY1989 by the new units, becquerel, gray and sievert, respectively due to adoption of the law on the international new unit system.

<Reference> Radiation Doses and Their Physical Effects

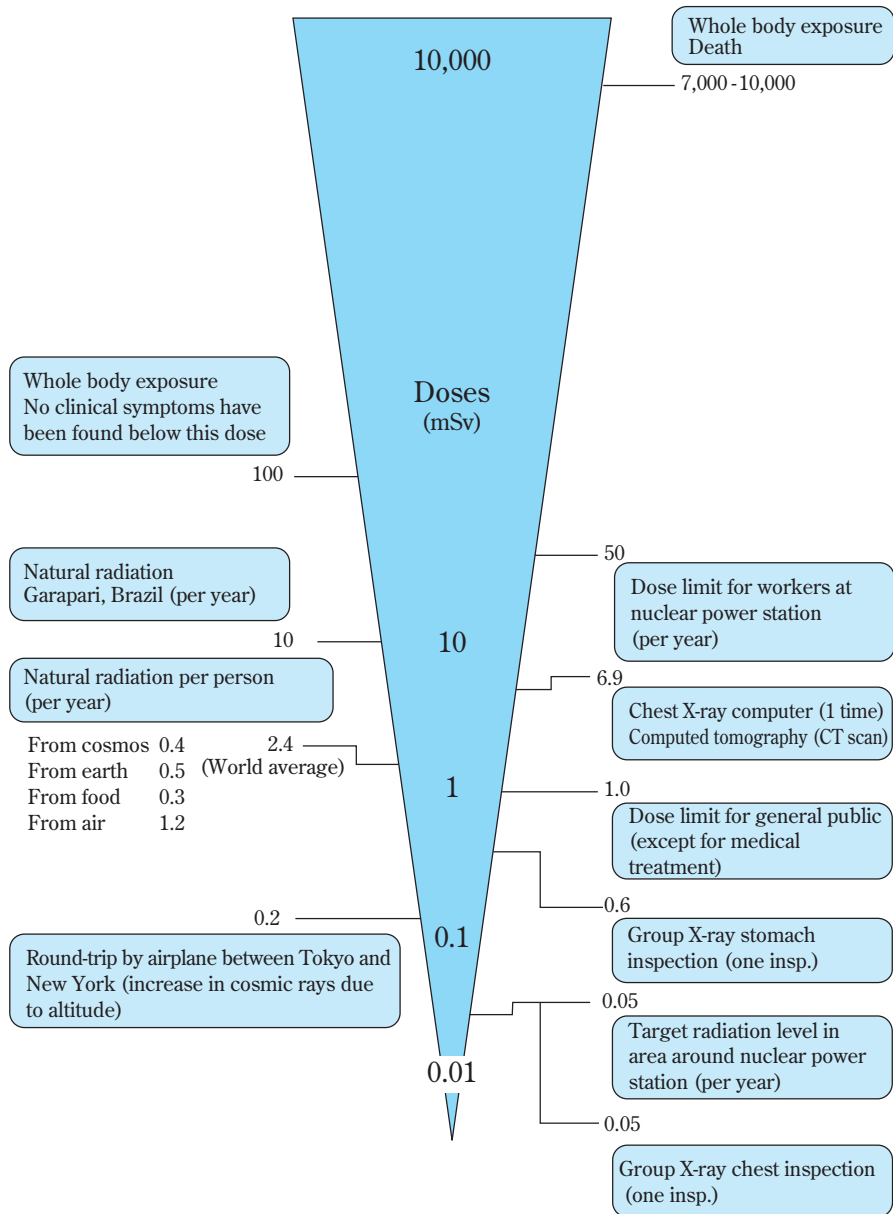

- Notes:
1. For the values in this figure, the effective dose equivalent or effective dose is described.
 2. For the amount of natural radiation, the value including the effect of radon by aspiration is described.

Sources: "Report of United Nations Scientific Committee on the Effects of Atomic Radiation 2000," "ICRP Pub 103," etc.

2. Nuclear Fuel Cycle

(1) Outline of Nuclear Fuel Cycle Facilities

	Uranium Enrichment Plant	Low-Level Radioactive Waste Underground Disposal Center	Reprocessing Plant	Vitrified Waste Storage Center	MOX Fuel Fabrication Plant
Site	Oishitai, Rokkasho-mura, Kamikita-gun, Aomori-Prefecture		Iyasakatai, Rokkasho-mura, Kamikita-gun, Aomori-Prefecture		
Project Executor	Japan Nuclear Fuel Limited				
Capacity	Authorized capacity : 1,050 ton-SWU/year (initial operation) Final : 1,500 ton-SWU/year	Authorized capacity : approx. 80,000m ³ (equivalent to 0.4 million drums of 200 ℓ) Projected capacity : approx. 600,000m ³ (equivalent to 3 million drums of 200 ℓ)	Maximum capacity : 800 tU/year Storage capacity for spent fuel : 3,000 tU	Capacity of wastes returned from overseas reprocessing plants : 2,880 canisters of vitrified waste	Maximum capacity : 130 tHM/year
Site Square Area	Oishitai approx. 3.6 million m ² (including roads for plant use only, etc.)		Iyasakatai approx. 3.8 million m ² (including roads for plant use only, etc.)		
Schedule	Beginning of construction : 1988 Beginning of operation : 1992	Beginning of construction : 1990 Beginning of operation : 1992	Beginning of construction : 1993 Beginning of water flow functional testing : 2001 Beginning of chemical testing : 2002 Beginning of uranium testing : 2004 Beginning of active testing : 2006 Commercial operation : 2013 (planned)	Beginning of construction : 1992 Beginning of operation : 1995	Beginning of construction : 2010 Beginning of operation (planned) : 2016
Construction Expense	Approx. 250 billion yen	Approx. 160 billion yen*	Approx. 2,193 billion yen	Approx. 125 billion yen	Approx. 190 billion yen

* Construction expense for 200,000 m³ low-level radioactive waste (equivalent to Approx. 1 million 200 ℓ drums)

Note: tU = tones of uranium

In spent fuel, uranium and oxygen are combined. A unit of tones of uranium is the weight of spent fuel minus the weight of oxygen.

(2) Japan's Procurement of Uranium (as of March 2010)

Import Contract Type	Supply Countries (country of origin for the portion of import of development)	Contract Quantity (st U ₃ O ₈)
Long- and short-term contracts, and purchase of products	Canada, United Kingdom, South Africa, Australia, France, U.S.A, etc.	Approx. 377,300
Develop-and-import scheme	Niger, Canada, Australia, Kazakhstan	Approx. 83,800
Total		Approx. 461,100

Source: "Nuclear Pocket Book 2011"

Note: st = short ton
Short ton is a unit of weight used mainly in the United States; one short ton is equivalent to approx. 907 kg.

(3) Amount of Spent Fuel Storage

a. Amount of Spent Fuel Storage

(Unit: Number of fuel assemblies)

Power station	Amount of Storage							Storage Capacity
	End of FY 2005	End of FY 2006	End of FY 2007	End of FY 2008	End of FY 2009	End of FY 2010	End of FY 2011	
Fukushima Daiichi	8,153	8,725	9,117	9,657	10,149	10,781	11,329	15,558
Fukushima Daini	5,532	5,130	5,628	5,614	6,122	6,476	6,476	10,940
Kashiwazaki-Kariwa	11,936	11,856	12,372	12,380	12,672	13,160	13,380	22,479
Total	25,621	25,711	27,117	27,651	28,943	30,417	31,185	48,977

(as of the end of March 2011)

b. Outline of Operation Auxiliary Common Facility (Common Pool) at Fukushima Daiichi Nuclear Power Station

- Completed in October 1997.
- Scale of facility: Approx. 55 m (W) × approx. 73 m (L) × approx. 35 m (H)
- Storage capacity: 6,840 assemblies (90 assembly racks × 76 units)
(Approx. 200% of the amount of total reactor core loading)
Approx. 12 m (W) × approx. 29 m (L) × approx. 11 m (D)
- Storage system: Water pool system
- Accessory equipment
 - Cooling and filtering system : 2 systems (Eventual heat exchange with air)
 - Automatic fuel handling machine : 1 unit
 - Cask transporting system : 1 unit
 - Overhead traveling crane : 2 units (Pool area and cask transport incoming and outgoing area)
 - Transportation cask : 5 casks (Building has a 10 cask storage capacity)

c. Outline of Spent Fuel Storage Cask at Fukushima Daiichi Nuclear Power Station

Item	Large Storage Cask	Medium Storage Cask
Weight	Approx. 115 tons	Approx. 96 tons
Overall Length	Approx. 5.6 m	Approx. 5.6 m
Outside Diameter	Approx. 2.4 m	Approx. 2.2 m
Number of Assemblies Stored	52 assemblies	37 assemblies
Main Structural Materials	Barrel	Alloy steel forging for low temperature service
	Neutron Shield	Resin (Silicon resin)
	Primary Cover	Alloy steel forging for low temperature service
	Secondary Cover	Stainless steel forging
	Basket	Aluminum alloy with boron additive (boron content: About 1%)
Internal Filling Gas	Helium gas	
Type of Cover	Double cover system	
Sealing Material	Metal gasket	

(4) Overview of Recycled Fuel Storage Center

In February 2004, TEPCO asked for the cooperation of Aomori Prefecture and Mutsu city in locating of the facility (location cooperation request), and gained approval from the both government in October 2005.

In November 2005, TEPCO and The Japan Atomic Power Company who promotes the business collectively have established Recyclable-Fuel Storage Company in Mutsu city. This company had conducted detailed research of the site applied to the Minister of Economy, Trade and Industry for permission for spent fuel storage business of "Recycled Fuel Storage Center" in March 2007, and acquired the business license in May 2010. The company began the construction in August 2010.

Conceptual drawing of Recycled Fuel Storage Center

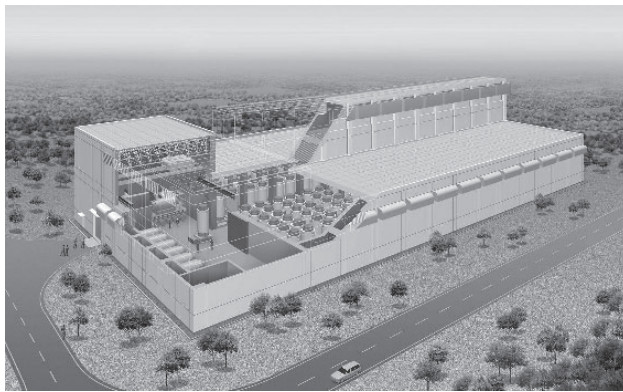

3,000 ton storage building [approx. 130m × 60m × (height) 30m]

Overview of Recycled Fuel Storage Center	
Planned Site of Facility	At Mizukawame, Oaza-Sekine, Mutsu, Aomori Pref.
Main Undertaking	Recyclable-Fuel Storage Co., jointly established by TEPCO and Japan Atomic Power Co.
Start of Operations	Expected to start operation in 2013.
Scale of the Facility	Final storage volume: 5,000 tons-U (3,000 tons-U in the first building) * TEPCO's storage share: approx. 4,000 tons-U * Japan Atomic Power Company's storage share: approx. 1,000 tons-U
Storage Period	The period of use for each facility is 50 years, and the maximum storage period for each cask is also 50 years. * Discussion will be made on removal of stored fuel for recycling within 40 years from start of operations. Note: "Each cask" refers to a storage container that will be put in succession.
Construction Cost	Approx. 100 billion yen (including metal casks) * Metal casks account for 70-80 percent of all construction cost.

(5) Current Status of Nuclear Fuel Reprocessing Contracts

TEPCO has concluded agreements with Nuclear Decommissioning Authority (NDA of the U.K.), AREVA NC (nuclear fuel company in France), Japan Atomic Energy Agency and Japan Nuclear Fuel to reprocess uranium. The following table describes the current status of this endeavor.

(as of the end of March 2012)

Contractors	AREVA NC	NDA	JAEA	JNFL
Reprocessing Plant Name	UP-3 Plant	THORP Plant	Tokai Reprocessing Plant	Rokkasho Reprocessing Plant
Annual Reprocessing Capacity (tU)	1,000/year	1,200/year	40tU · P/year	800/year
Contract Amount (tU)	Approx. 630	Approx. 1,244	Approx. 223	Approx. 12,082
Spent Fuel Delivery Period: Amount Actually Delivered as of the End of March 2010 (tU)	1985 - 1993 Approx. 630	1974 - 1995 Approx. 1,244	1977 - Approx. 223	1998 - Approx. 1,058
Construction and Operation of Reprocessing Plant	<ul style="list-style-type: none"> • November 1989 : Operations partially begun. • August 1990 : Full scale operations begun. 	<ul style="list-style-type: none"> • March 1994 : Operations begun. 	<ul style="list-style-type: none"> • September 1977 : Active test started. • 1981 : Full start-up begun. 	<ul style="list-style-type: none"> • March 2006 : Active test started. • 2012 : Full scale operations scheduled.
Amount Actually Reprocessed as of the End of March 2012 : Amount of Spent Fuel Reprocessed by TEPCO (tU)	Approx. 630	Approx. 1,244	Approx. 223	Approx. 156

(6) High-Level Radioactive Waste Storage Conditions

High-level radioactive waste (vitrified material) that is returned from France and the U.K. is all stored and managed in Vitrified Waste Storage Center of Japan Nuclear Fuel Ltd. located in Rokkasho-mura, Aomori Prefecture.

	Quantity	TEPCO use	Reprocessing Plant	Arrival Date (in Japan)
1st return	28 canisters	7 canisters	France	April 1995
2nd return	40 canisters	10 canisters	France	March 1997
3rd return	60 canisters	20 canisters	France	March 1998
4th return	40 canisters	0 canister	France	April 1999
5th return	104 canisters	28 canisters	France	February 2000
6th return	192 canisters	60 canisters	France	February 2001
7th return	152 canisters	28 canisters	France	January 2002
8th return	144 canisters	28 canisters	France	July 2003
9th return	132 canisters	18 canisters	France	March 2004
10th return	124 canisters	0 canister	France	April 2005
11th return	164 canisters	42 canisters	France	March 2006
12th return	130 canisters	20 canisters	France	March 2007
13th return	28 canisters	7 canisters	U.K.	March 2010
14th return	76 canisters	0 canister	U.K.	September 2011
Total	1,414 canisters	268 canisters		

Note: High-level radioactive waste is vitrified and put in stainless canisters that measure approx. 0.4 m in diameter, approx. 1.3 m in height, and weigh approx. 0.5 tons.

<Reference> Schedule of Geological Disposal Project

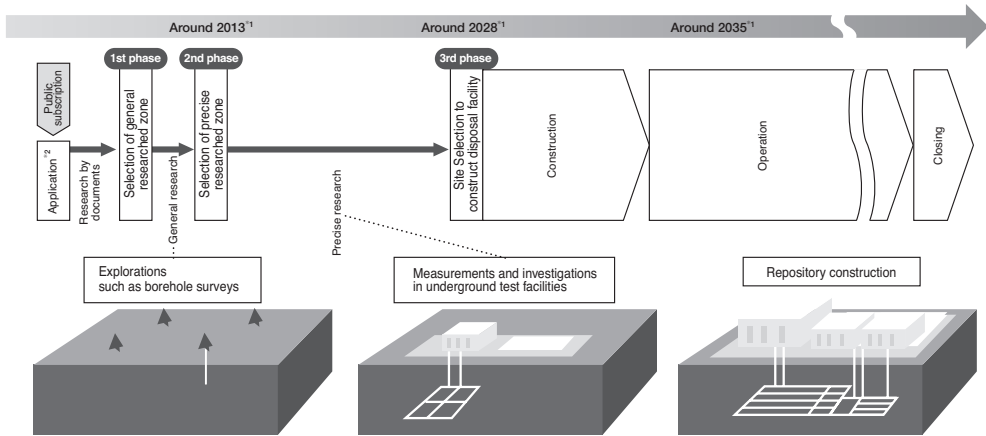

*1 Based on "Final disposal plan (March 2008)"

*2 The government can nominate the site for literature survey, taking account of opinions of local communities. In this case, mayor will express whether they will accept the proposals or not.

Sources: "Geological Disposal of Radioactive Waste in Japan," Nuclear Waste Management Organization of Japan (NUMO).

<Reference> Nuclear Fuel Cycle Concept

* Natural uranium used as fuel for the nuclear power plants is fabricated through a series of processes that is then used in nuclear power plants. Spent fuel contains reusable uranium and newly produced plutonium. Reprocessing spent fuel recovers this valuable, reusable material, which can be recycled. This process from mining uranium ore to recycling of spent fuel is called the "nuclear fuel cycle."

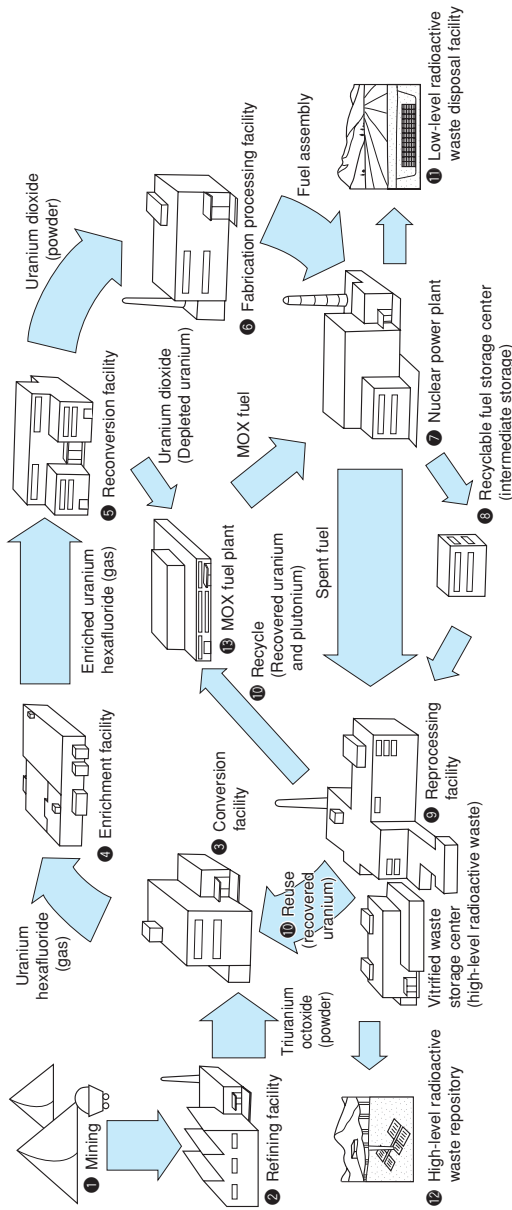

- 1 Mining:
- 2 Refining facility:
- 3 Conversion facility:
- 4 Enrichment facility:
- 5 Reconversion facility:
- 6 Fabrication processing facility:
- 7 Nuclear power plant:
- 8 Reprocessing facility:
- 9 Low-level radioactive waste disposal facility:
- 10 High-level radioactive waste repository:
- 11 MOX fuel plant

Digging uranium ore from a mine.

Extracting uranium from ore and turning it into triuranium octoxide (yellow powder called "yellow cake").

Converting triuranium octoxide into gaseous uranium hexafluoride by removing impurities and adding fluoride.

Increasing the percentage of "combustible" uranium 235 content, which is no more than 0.7 percent in uranium hexafluoride, to 3-5 percent.

Converting enriched uranium hexafluoride into powdery uranium dioxide.

Baking powdery uranium into fuel pellets, putting them in zirconium alloy fuel rod, and adding dozens of such fuel rods into the fuel assembly.

Bring the fuel assembly into nuclear reactor (combustion) to generate electricity. Nuclear fuel continues burning for 4 to 5 years.

Spent fuel from nuclear power plant is stored and controlled as recyclable fuel until reprocess.

Extracting uranium and newly produced plutonium from used nuclear fuel through chemical treatment processes, and separating radioactive waste.

Uranium and plutonium recovered through reprocessing are transported to conversion and fabrication processing facilities to be reused as fuel.

Low-level radioactive waste produced in facility operation and dismantling is buried underground with most appropriate methods according to the waste's nuclear concentration content.

High-level radioactive waste, which is vitrified, is stored for 30 to 50 years for cooling, and buried underground below 300 meters from the surface, for good.

The powdered MOX fuel received from the reprocessing facility is processed into the fuel used at the nuclear power station (MOX fuel).

VII. Accounting

1. Profit and Financial Structure Improvement Targets

(1) Changes in Standard Profits

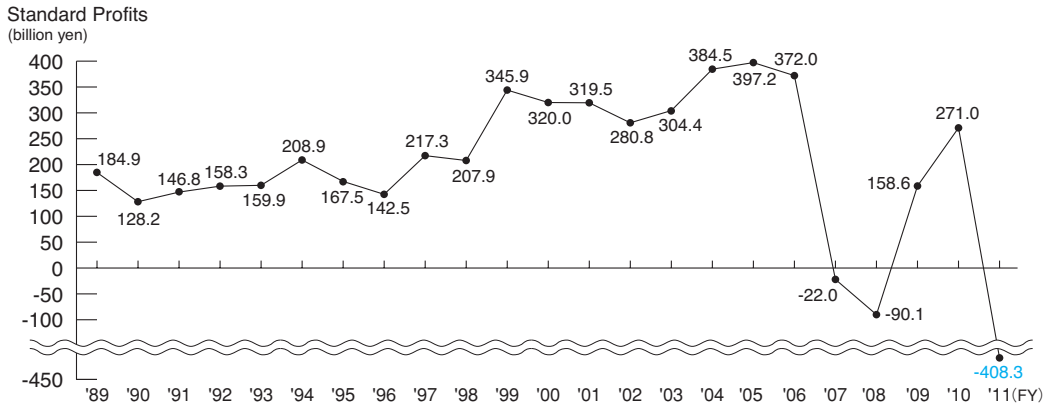

(2) Changes in ROA/ROE

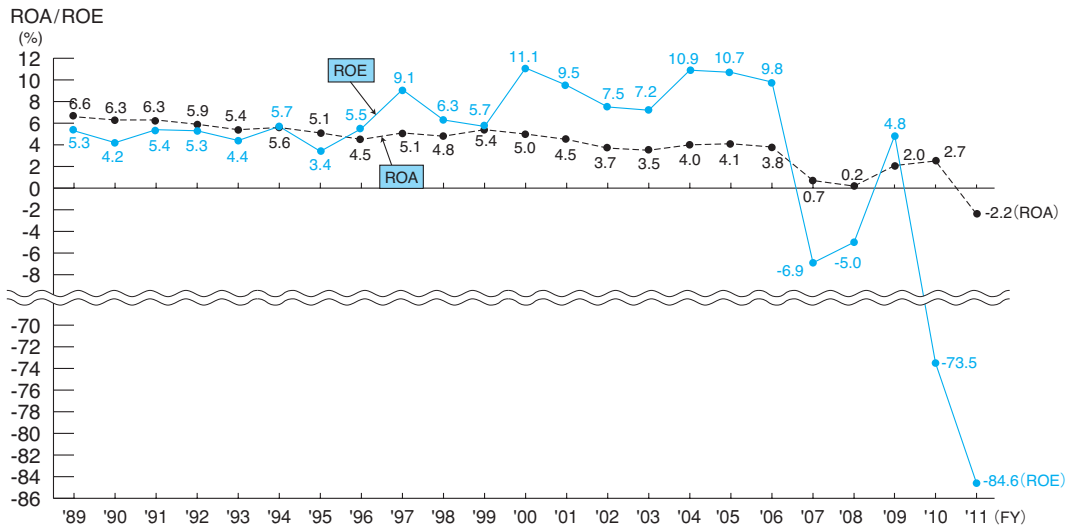

Note: ROA: Operating income/Average gross assets. ROE: Net income/Average shareholders' equity.

(3) Changes in Outstanding Amount of Interest-Bearing Liabilities

Outstanding Amount of Interest-Bearing Liabilities
(Trillion yen)

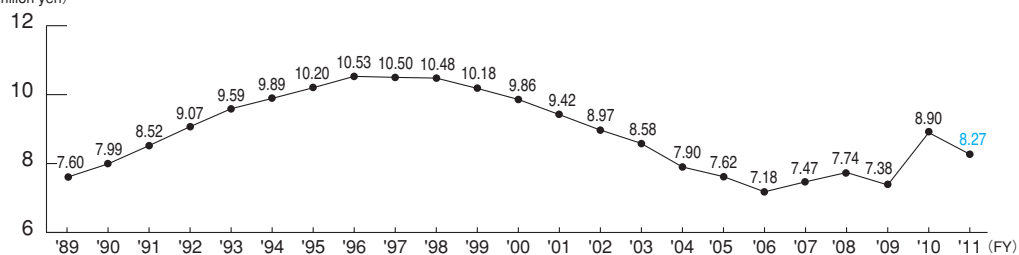

Note: Outstanding amount of interest-bearing liabilities: corporate bonds and outstanding amount of debt loan

(4) Changes in Shareholders' Equity Ratio

Shareholders' Equity Ratio
(%)

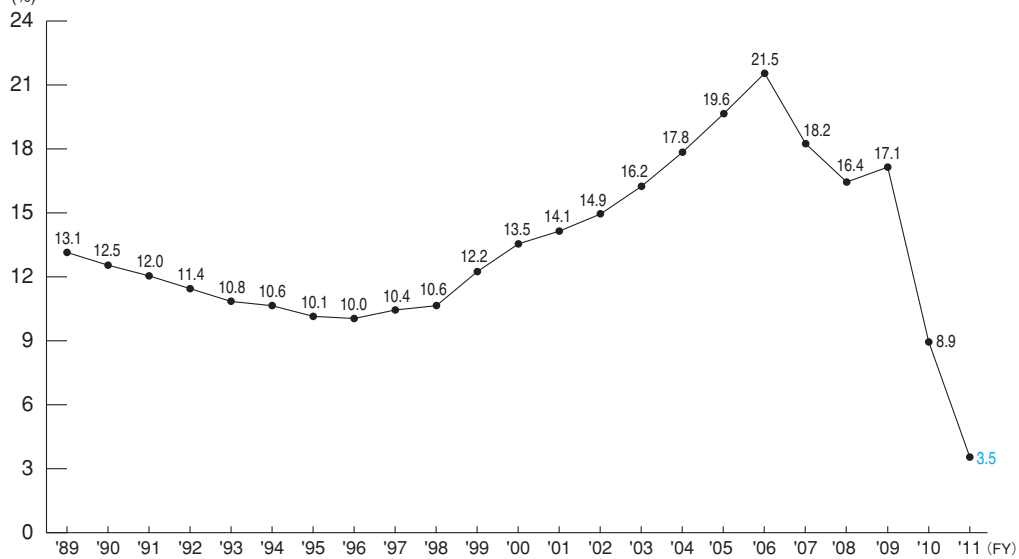

Note: Shareholders' Equity Ratio: (Net asset - Share warrant) / Total assets and shareholders' equity

2. Balance Sheet

(1) Non-Consolidated

(Unit: billion yen)

	FY	2002	2003	2004	2005	2006	2007	2008	2009	2010	2011
Assets											
Fixed assets		13,254.7	12,889.0	12,532.3	12,429.3	12,242.7	12,249.6	11,946.5	11,855.4	11,530.3	13,019.9
Electric utility fixed assets		9,833.9	9,723.4	9,310.9	9,154.9	8,770.5	8,416.0	8,159.5	7,871.7	7,673.2	7,440.5
Hydroelectric power production facilities		712.7	676.8	643.0	878.8	835.6	791.4	751.6	715.6	682.0	647.6
Thermal power production facilities		1,292.7	1,546.6	1,474.0	1,328.0	1,202.9	1,116.5	1,127.3	1,032.4	946.1	851.8
Nuclear power production facilities		1,025.9	932.8	858.3	794.9	739.4	679.4	643.8	670.9	737.6	729.7
Internal combustion engine power production facilities		11.6	13.7	12.7	9.5	9.4	11.5	10.4	9.9	9.6	68.8
Renewable energy generation facilities		-	-	-	-	-	-	-	1.1	1.0	14.1
Transmission facilities		2,983.3	2,833.6	2,713.5	2,596.5	2,490.8	2,381.6	2,281.3	2,177.9	2,102.3	2,019.4
Transformation facilities		1,181.7	1,128.2	1,056.0	1,013.8	986.8	948.4	899.7	866.3	834.4	792.2
Distribution facilities		2,397.7	2,363.3	2,349.4	2,330.2	2,314.5	2,293.3	2,267.1	2,231.5	2,198.4	2,167.1
General facilities and others		228.0	228.1	203.8	202.8	190.7	193.5	178.0	165.6	161.5	149.4
Facilities in progress		1,212.1	805.3	738.5	482.4	526.2	595.0	590.6	650.9	700.2	882.1
Nuclear fuel		856.0	911.5	929.1	920.9	896.8	923.9	917.0	903.5	870.4	845.7
Other fixed assets		1,352.6	1,448.7	1,553.7	1,871.0	2,049.1	2,314.5	2,279.2	2,429.3	2,286.2	3,851.4
Current assets		557.7	544.9	568.5	601.8	681.2	808.0	1,043.5	787.5	2,725.6	2,129.3
Deferred charges		-	0.3	0.2	0.2	-	-	-	-	-	-
Total		13,812.5	13,434.3	13,101.1	13,031.4	12,924.0	13,057.7	12,990.0	12,643.0	14,255.9	15,149.2
Liabilities and Net Asset (Shareholders' Equity)											
Long-term liabilities		9,222.5	9,271.4	8,985.2	8,189.6	7,808.2	8,350.5	8,841.8	8,549.8	11,088.7	12,275.7
Bonds		5,142.9	5,550.2	5,376.5	4,899.1	4,529.9	4,694.4	4,936.3	4,739.1	4,425.1	3,677.2
Long-term loans		1,994.5	1,682.2	1,476.0	1,210.9	1,160.2	1,294.7	1,528.1	1,466.3	3,280.1	3,216.3
Other long-term liabilities		2,085.0	2,038.8	2,132.5	2,079.6	2,118.0	2,361.3	2,377.4	2,344.3	3,383.4	5,382.1
Current liabilities		2,527.1	1,981.3	1,761.6	2,270.4	2,320.2	2,307.2	2,003.6	1,927.5	1,891.2	2,332.4
Reserve for fluctuation in water levels		4.2	11.8	19.5	16.3	22.3	17.3	13.4	5.0	11.1	13.5
Total liabilities		11,754.0	11,264.5	10,766.4	10,476.4	10,150.8	10,675.0	10,858.9	10,482.3	12,991.1	14,621.7
Capital stock		676.4	676.4	676.4	676.4	-	-	-	-	-	-
Capital surplus		19.0	19.0	19.0	19.0	-	-	-	-	-	-
Capital reserve		19.0	19.0	19.0	19.0	-	-	-	-	-	-
Earned surplus		1,345.5	1,416.1	1,579.8	1,759.5	-	-	-	-	-	-
Revenue reserve		169.1	169.1	169.1	169.1	-	-	-	-	-	-
Various reserves		295.5	295.5	295.7	295.6	-	-	-	-	-	-
(cost fluctuation adjustment)		(295.2)	(295.2)	(295.2)	(295.2)	-	-	-	-	-	-
General reserve		620.0	691.0	761.0	924.0	-	-	-	-	-	-
Unappropriated retained earnings		260.8	260.4	353.9	370.7	-	-	-	-	-	-
Unrealized gains on securities		19.4	61.5	63.9	105.1	-	-	-	-	-	-
Treasury stock		-1.8	-3.3	-4.3	-5.1	-	-	-	-	-	-
Total shareholders' equity		2,058.5	2,169.7	2,334.7	2,555.0	-	-	-	-	-	-
Shareholders' equity		-	-	-	-	2,629.8	2,350.5	2,155.8	2,176.8	1,286.2	527.7
Capital stock		-	-	-	-	676.4	676.4	676.4	676.4	900.9	900.9
Capital surplus		-	-	-	-	19.0	19.1	19.1	19.1	243.6	243.6
Capital reserve		-	-	-	-	19.0	19.0	19.0	19.0	243.5	243.5
Other capital surplus		-	-	-	-	0.0	0.1	0.1	0.1	0	0
Earned surplus		-	-	-	-	1,940.5	1,661.5	1,467.4	1,488.7	149.1	-609.2
Legal reserve		-	-	-	-	169.1	169.1	169.1	169.1	169.1	169.1
Other earned surplus		-	-	-	-	1,771.3	1,492.4	1,298.3	1,319.6	-19.9	-778.3
Various reserves		-	-	-	-	295.5	295.4	0.2	0.5	0.5	0.5
(cost fluctuation adjustment)		-	-	-	-	(295.2)	(295.2)	(-)	(-)	(-)	(-)
General reserve		-	-	-	-	1,103.0	1,270.0	1,270.0	1,076.0	1,076.0	1,076.0
Earned surplus carried forward		-	-	-	-	372.8	-72.9	28.0	243.0	-1,096.4	-1,854.8
Treasury stock		-	-	-	-	-6.1	-6.5	-7.1	-7.4	-7.5	-7.5
Valuation and translation adjustment		-	-	-	-	143.3	32.1	-24.7	-16.2	-21.4	-0.3
Unrealized gains on securities		-	-	-	-	143.3	32.1	-24.7	-16.2	-21.4	-0.3
Loss on deferred hedge		-	-	-	-	-	0.0	-	-	-	-
Total net asset		-	-	-	-	2,773.2	2,382.7	2,131.1	2,160.6	1,264.8	527.4
Total		13,812.5	13,434.3	13,101.1	13,031.4	12,924.0	13,057.7	12,990.0	12,643.0	14,255.9	15,149.2

- Notes:
- Fractions smaller than 0.1 billion yen are rounded down.
 - Since FY2006, the accounting standard related to display of net asset part of balance sheet has been applied.
 - Since FY2009, new energy-based power production equipment of new energy is booked as a separate item to comply with the amended Accounting Rules for Electricity Business.

(2) Consolidated

(Unit: billion yen)

	FY	2002	2003	2004	2005	2006	2007	2008	2009	2010	2011
Assets	Fixed assets	13,556.1	13,269.7	13,025.9	12,848.5	12,670.6	12,697.5	12,351.2	12,221.4	11,875.6	13,250.2
	Electric utility fixed assets	9,742.6	9,636.6	9,229.5	9,079.6	8,699.6	8,351.3	8,099.0	7,814.2	7,605.4	7,375.5
	Hydroelectric power production facilities	719.2	683.4	649.5	885.4	842.2	800.5	761.5	725.5	679.8	645.5
	Thermal power production facilities	1,287.9	1,541.8	1,469.8	1,324.6	1,199.8	1,113.9	1,124.8	1,030.8	944.3	850.1
	Nuclear power production facilities	1,022.7	929.4	855.0	792.0	736.6	676.7	641.1	667.8	734.1	726.2
	Transmission facilities	2,966.0	2,817.7	2,698.7	2,583.1	2,479.4	2,370.9	2,271.2	2,168.0	2,092.3	2,009.5
	Transformation facilities	1,168.7	1,116.5	1,045.4	1,004.8	978.7	941.0	893.3	860.3	828.7	787.3
	Distribution facilities	2,338.8	2,306.4	2,294.7	2,277.3	2,262.6	2,243.3	2,218.7	2,185.0	2,153.9	2,124.5
	General facilities and others	239.0	241.3	216.1	212.0	199.9	204.8	188.2	176.5	171.9	232.1
	Facilities in progress	1,228.2	848.0	776.9	519.9	556.6	659.6	648.5	686.7	749.9	943.5
	Nuclear fuel	854.1	909.3	925.1	917.1	893.7	921.8	915.9	902.9	869.9	845.3
	Other fixed assets, etc.	1,731.0	1,875.7	2,094.2	2,331.9	2,520.6	2,764.6	2,687.6	2,817.4	2,650.2	4,085.6
Current assets	621.1	630.8	722.5	745.2	850.7	981.5	1,208.0	982.5	2,914.7	2,286.2	
Deferred changes	-	0.3	0.2	0.2	-	-	-	-	-	-	
Total profit	14,177.2	13,900.9	13,748.8	13,594.1	13,521.3	13,679.0	13,559.3	13,203.9	14,790.3	15,536.4	
Liabilities and Net Asset (Shareholders' Equity)	Long-term liabilities	9,368.1	9,497.5	9,361.1	8,432.3	8,073.7	8,602.6	9,067.7	8,769.3	11,301.7	12,391.4
	Bonds	5,145.9	5,555.1	5,400.3	4,905.2	4,535.0	4,697.4	4,937.0	4,739.6	4,425.5	3,677.4
	Long-term loans	2,072.5	1,836.3	1,749.2	1,372.7	1,335.6	1,458.8	1,687.5	1,614.3	3,423.7	3,276.1
	Other long-term liabilities	2,149.6	2,106.0	2,211.5	2,154.4	2,203.0	2,446.3	2,443.1	2,415.3	3,452.3	5,437.8
	Current liabilities	2,545.7	2,003.8	1,833.4	2,329.8	2,351.4	2,363.5	2,058.5	1,913.0	1,874.9	2,318.9
	Reserve for fluctuation in water levels	4.2	11.9	19.7	16.4	22.4	17.4	13.5	5.1	11.1	13.5
	Total liabilities	11,918.1	11,513.3	11,214.3	10,778.6	10,447.6	10,983.6	11,139.8	10,687.5	13,187.8	14,723.9
	Shareholders' equity	-	-	-	-	2,875.5	2,626.1	2,460.1	2,519.0	1,630.3	848.7
	Capital stock	-	-	-	-	676.4	676.4	676.4	676.4	900.9	900.9
	Capital surplus	-	-	-	-	19.0	19.1	19.1	19.1	243.6	243.6
	Earned surplus	-	-	-	-	2,186.8	1,937.8	1,772.3	1,831.4	494.0	-287.4
	Treasury stock	-	-	-	-	-6.7	-7.1	-7.7	-8.0	-8.3	-8.3
	Accumulated other comprehensive income	-	-	-	-	157.9	27.5	-81.5	-53.2	-72.1	-61.5
	Unrealized gains on securities	-	-	-	-	155.0	37.5	-26.1	-15.6	-20.0	1.2
	Loss on deferred hedge	-	-	-	-	-1.1	-12.8	-22.9	-10.4	-11.1	-16.7
	Land revaluation surplus	-	-	-	-	-3.6	-3.6	-3.6	-3.6	-3.6	-3.2
	Translation adjustments	-	-	-	-	7.6	6.5	-28.8	-23.4	-37.3	-42.8
	Share warrant	-	-	-	-	0.0	-	-	0.0	0.0	-
	Minority interests	13.2	27.1	32.2	35.6	40.2	41.6	40.8	50.7	44.3	25.2
	Total net asset	-	-	-	-	3,073.7	2,695.4	2,419.4	2,516.4	1,602.4	812.4
Total of liabilities and net asset	-	-	-	-	13,521.3	13,679.0	13,559.3	13,203.9	14,790.3	15,536.4	
Capital stock	676.4	676.4	676.4	676.4	-	-	-	-	-	-	
Capital surplus	19.0	19.0	19.0	19.0	-	-	-	-	-	-	
Earned surplus	1,527.4	1,595.9	1,740.9	1,969.9	-	-	-	-	-	-	
Land revaluation surplus	0.9	0.6	0.5	-3.6	-	-	-	-	-	-	
Unrealized gains on securities	20.6	71.8	69.9	117.7	-	-	-	-	-	-	
Translation adjustments	3.7	0.4	0.2	5.8	-	-	-	-	-	-	
Treasury stock	-2.4	-3.9	-4.9	-5.7	-	-	-	-	-	-	
Total shareholders' equity	2,245.8	2,360.4	2,502.1	2,779.7	-	-	-	-	-	-	
Total of liabilities, minority interests and shareholders' equity	14,177.2	13,900.9	13,748.8	13,594.1	-	-	-	-	-	-	

- Notes: 1. Fractions smaller than 0.1 billion yen are rounded down.
2. Since FY2006, the accounting standard related to display of net asset part of balance sheet has been applied.

3. Statement of Income

(1) Non-Consolidated

(Unit: billion yen)

FY		2002	2003	2004	2005	2006	2007	2008	2009	2010	2011
Revenues	Operating revenues	4,880.4	4,734.5	4,823.2	4,941.0	5,015.0	5,224.3	5,643.3	4,804.4	5,146.3	5,107.7
	Electric utility operating revenues	4,801.3	4,722.1	4,798.6	4,897.2	4,952.3	5,169.1	5,554.2	4,733.2	5,064.6	4,995.6
	Residential	1,955.5	1,909.4	1,976.8	2,022.4	1,983.4	2,096.2	2,207.8	2,008.6	2,167.8	2,133.4
	Commercial and industrial	2,729.7	2,688.7	2,660.4	2,659.5	2,721.1	2,818.4	3,088.1	2,495.9	2,628.7	2,620.6
	Sales to other electric utilities etc.	71.7	71.9	101.1	143.9	168.6	164.3	169.7	136.2	162.4	140.0
	Other operating revenues	44.3	51.9	60.2	71.2	79.0	90.0	88.5	92.4	105.5	101.5
	Incidental business operating revenues	7.0	12.4	24.6	43.8	62.7	55.2	89.1	71.1	81.6	112.1
	Nonoperating revenues	18.5	25.9	28.5	37.6	42.8	41.4	39.9	48.2	57.2	76.5
	Financing revenues	10.1	15.3	10.4	10.8	17.0	20.4	26.5	31.1	42.5	62.0
	Other nonoperating revenues	8.3	10.5	18.0	26.8	25.8	20.9	13.3	17.1	14.6	14.5
Total ordinary revenues	4,826.9	4,760.4	4,851.7	4,978.7	5,057.9	5,265.8	5,683.3	4,852.7	5,203.5	5,184.3	
Expenses	Operating expenses	4,296.2	4,262.3	4,287.7	4,404.3	4,519.1	5,129.3	5,620.6	4,554.5	4,789.6	5,426.9
	Electric utility operating expenses	4,282.2	4,231.5	4,231.8	4,325.0	4,426.2	5,075.0	5,532.6	4,487.5	4,710.4	5,319.3
	Hydroelectric power production expenses	95.0	91.0	96.2	98.0	101.6	94.1	89.9	86.5	89.7	78.7
	Thermal power production expenses	1,099.1	1,252.2	1,141.4	1,315.3	1,311.5	2,032.1	2,365.4	1,462.4	1,712.2	2,509.4
	Nuclear power production expenses	521.3	464.3	582.8	556.1	584.3	536.6	469.4	492.3	518.6	428.7
	Internal combustion engine power production expenses	5.9	7.7	7.5	9.8	7.1	7.0	9.8	7.2	7.5	75.8
	Renewable energy generation expenses	-	-	-	-	-	-	-	0.3	0.6	0.8
	Power purchased from other electric utilities etc.	619.8	637.1	600.8	629.3	650.6	773.1	842.5	722.4	703.5	780.8
	Transmission expenses	400.1	384.4	382.5	386.8	387.2	378.4	358.6	356.4	350.8	333.0
	Transformation expenses	211.8	197.8	194.6	184.7	180.8	171.9	163.2	159.6	161.9	142.5
	Distribution expenses	495.5	481.2	500.4	479.8	482.8	485.8	473.1	476.5	480.2	425.2
	Selling expenses	192.6	191.8	193.5	191.7	196.5	196.4	187.4	188.9	189.2	149.5
	General and administrative expenses	459.1	346.8	349.1	293.7	342.9	220.8	393.7	369.8	321.3	232.0
	Electric power development promotion tax	126.1	121.6	124.5	118.9	119.0	115.4	111.9	108.8	114.8	104.9
	Enterprise tax	55.7	54.4	55.7	56.8	57.2	58.5	63.0	52.5	56.4	54.6
	Other operations expenses	-0.4	0.8	2.3	3.5	4.1	4.2	4.2	3.1	3.0	2.6
	Incidental business operating expenses	13.9	30.7	55.8	79.3	92.8	54.3	87.9	66.9	79.1	107.5
	(Operating income)	512.2	472.2	535.4	536.7	495.9	95.0	22.7	249.9	356.6	-319.1
	Nonoperating expenses	249.9	193.6	179.4	177.1	166.7	158.4	152.9	139.5	142.8	165.7
	Financing expenses	206.9	169.8	157.1	154.6	149.2	145.2	136.6	130.5	127.4	127.2
	Other nonoperating expenses	42.9	23.7	22.3	22.5	17.5	13.2	16.2	9.0	15.3	38.5
	Total ordinary expenses	4,546.1	4,455.9	4,467.2	4,581.5	4,685.8	5,287.8	5,773.5	4,694.0	4,932.4	5,592.7
	Ordinary income	280.8	304.4	384.5	397.2	372.0	-22.0	-90.1	158.6	271.0	-408.3
Water shortage reserve appropriated or drawn down	-1.7	7.5	7.7	-3.2	5.9	-5.0	-3.8	-8.4	3.8	0.9	
Reversal of or provision for the reserve for depreciation of nuclear plants construction	-	-	-	-	-	-	-	-	2.2	1.4	
Extraordinary profits	-	-	-	12.4	60.7	18.6	-	-	-	2,517.4	
Extraordinary loss	41.6	41.9	-	12.0	-	267.1	70.3	-	1,074.2	2,865.1	
Income before income taxes	240.9	254.9	376.7	400.8	426.8	-265.5	-156.6	167.0	-809.2	-758.4	
Income taxes	87.8	103.1	131.9	140.0	164.6	-87.9	-43.5	64.7	449.2	0.0	
Income taxes - current	125.5	88.0	133.6	129.9	179.3	0.2	0.0	0.0	0.0	0.0	
Income taxes - deferred	-37.7	15.1	-1.7	10.0	-14.6	-88.1	-43.5	64.7	449.2	-	
Net income	153.0	151.8	244.8	260.8	262.1	-177.6	-113.1	102.3	-1,258.5	-758.4	
Retained earnings brought forward	148.3	149.1	149.7	150.4	-	-	-	-	-	-	
Interim cash dividends paid	40.5	40.5	40.5	40.5	-	-	-	-	-	-	
Transfer to earned reserve	-	-	-	-	-	-	-	-	-	-	
Unappropriated retained earnings	260.8	260.4	353.9	370.7	-	-	-	-	-	-	

- Notes:
1. Fractions smaller than 0.1 billion yen are rounded down.
 2. Since FY2009, new energy-based power production expenses for new energy are booked as a separate item to comply with the amended Accounting Rules for Electricity Business.

(2) Consolidated

(Unit: billion yen)

FY		2002	2003	2004	2005	2006	2007	2008	2009	2010	2011
Revenues	Operating revenues	4,919.1	4,853.8	5,047.2	5,255.4	5,283.0	5,479.3	5,887.5	5,016.2	5,368.5	5,349.4
	Electric utility operating revenues	4,801.3	4,722.1	4,797.6	4,895.5	4,952.3	5,168.5	5,553.7	4,732.7	5,064.6	4,995.6
	Other operating revenues	117.7	131.7	249.5	359.9	330.7	310.8	333.8	283.4	303.9	353.8
	Nonoperating revenues	20.8	24.2	38.8	52.5	67.0	69.7	63.5	73.1	76.3	52.1
	Equity income under the equity method	-	-	1.1	5.3	13.6	9.1	13.8	12.6	16.0	-
	Other nonoperating revenues	20.8	24.2	37.7	47.2	53.3	60.5	49.6	60.5	60.2	52.1
	Total ordinary revenues	4,939.9	4,878.0	5,086.0	5,308.0	5,350.0	5,549.1	5,951.0	5,089.4	5,444.8	5,401.5
Expenses	Operating expenses	4,397.7	4,364.8	4,480.9	4,679.2	4,732.1	5,342.9	5,820.6	4,731.8	4,968.9	5,621.9
	Electric utility operating expenses	4,264.0	4,211.9	4,207.7	4,296.9	4,398.1	5,055.8	5,513.6	4,472.0	4,695.1	5,309.1
	Other operating expenses	133.6	152.8	273.1	382.3	333.9	287.0	307.0	259.8	273.7	312.7
	(Operating income)	(521.4)	(489.0)	(566.3)	(576.2)	(550.9)	(136.4)	(66.9)	(284.4)	(399.6)	(-272.5)
	Nonoperating expenses	271.1	205.5	196.9	201.8	176.6	173.0	165.1	153.2	158.2	180.0
	Equity loss under the equity method	13.3	16.5	-	-	-	-	-	-	-	6.4
	Other nonoperating expenses	257.7	189.0	196.9	201.8	176.6	173.0	165.1	153.2	158.2	173.5
Total ordinary expenses	4,668.8	4,570.3	4,677.8	4,881.0	4,908.7	5,516.0	5,985.7	4,885.1	5,127.1	5,802.0	
Ordinary income	271.1	307.7	408.2	426.9	441.2	33.1	-34.6	204.3	317.6	-400.4	
Water shortage reserve appropriated or drawn down	-1.7	7.6	7.7	-3.2	5.9	-5.0	-3.8	-8.4	3.8	0.9	
Reversal of or provision for the reserve for depreciation of nuclear plants construction	-	-	-	-	-	-	-	-	2.2	1.4	
Extraordinary profits	-	-	-	51.1	60.7	18.6	-	10.7	-	2,516.8	
Extraordinary loss	7.6	44.8	27.6	7.5	-	269.2	68.8	-	1,077.6	2,867.8	
Income before income taxes and minority interests	265.1	255.3	372.8	473.8	496.0	-212.4	-99.5	223.4	-766.1	-753.7	
Income taxes - current	134.1	98.3	146.2	146.3	202.8	17.5	18.5	20.1	18.4	19.0	
Income taxes - deferred	-33.4	8.6	-0.6	13.3	-8.9	-82.6	-37.2	66.5	459.9	3.7	
Minority interests	-0.8	-1.2	1.0	3.7	4.0	2.7	3.5	2.9	2.7	5.0	
Net income	165.2	149.5	226.1	310.3	298.1	-150.1	-84.5	133.7	-1,247.3	-781.6	

Note: Fractions smaller than 0.1 billion yen are rounded down.

4. Summary of Non-Consolidated Financial Results

(Unit: billion yen)

FY		2002	2003	2004	2005	2006	2007	2008	2009	2010	2011
Operating Revenues	Residential	1,955.5	1,909.4	1,976.8	2,022.4	1,983.4	2,096.2	2,207.8	2,008.6	2,167.8	2,133.4
	Commercial and industrial	2,729.7	2,688.7	2,660.4	2,659.5	2,721.1	2,818.4	3,088.1	2,495.9	2,628.7	2,620.6
	(Subtotal)	(4,685.2)	(4,598.1)	(4,637.2)	(4,682.0)	(4,704.6)	(4,914.7)	(5,295.9)	(4,504.5)	(4,796.5)	(4,754.0)
	Other	141.7	162.3	214.5	296.7	353.3	351.0	387.3	348.1	406.9	430.2
	(Total)	(4,826.9)	(4,760.4)	(4,851.7)	(4,978.7)	(5,057.9)	(5,265.8)	(5,683.3)	(4,852.7)	(5,203.5)	(5,184.3)
Operating Expenses	Personnel	544.2	445.1	454.4	401.0	458.9	337.7	483.4	481.3	431.1	366.8
	Fuel	782.6	905.8	822.4	1,040.0	1,062.7	1,755.1	2,078.7	1,192.6	1,482.1	2,286.9
	Maintenance	406.2	411.4	472.7	469.3	459.0	432.1	381.3	373.9	412.0	278.8
	Depreciation	882.8	845.0	785.9	753.4	704.5	726.2	708.6	709.8	655.6	645.5
	Purchased power	619.8	637.1	600.8	629.3	650.6	773.1	842.5	722.4	703.5	780.8
	Interest	203.9	167.9	156.3	153.7	148.0	143.0	134.6	129.5	124.4	127.2
	Taxes other than income taxes	348.6	338.9	343.9	336.4	337.0	330.2	327.3	312.8	325.9	303.2
	Nuclear power back-end costs	757.6	704.4	830.4	798.0	195.5	164.5	132.9	138.5	147.4	105.1
	Other	(4,546.1)	(4,455.9)	(4,467.2)	(4,581.5)	(4,685.8)	(5,287.8)	(5,773.5)	(4,694.0)	(4,932.4)	(5,592.7)
	(Total)	(4,546.1)	(4,455.9)	(4,467.2)	(4,581.5)	(4,685.8)	(5,287.8)	(5,773.5)	(4,694.0)	(4,932.4)	(5,592.7)
Ordinary income		280.8	304.4	384.5	397.2	372.0	-22.0	-90.1	158.6	271.0	-408.3
Water shortage reserved		-1.7	7.5	7.7	-3.2	5.9	-5.0	-3.8	-8.4	3.8	0.9
Reserve for depreciation of nuclear plants construction		-	-	-	-	-	-	-	-	2.2	1.4
Extraordinary profits		-	-	-	12.4	60.7	18.6	-	-	-	2,517.4
Extraordinary loss		41.6	41.9	-	12.0	-	267.1	70.3	-	1,074.2	2,865.1
Income taxes - current		125.5	88.0	133.6	129.9	179.3	0.2	0.0	0.0	0.0	0.0
Income taxes - deferred		-37.7	15.1	-1.7	10.0	-14.6	-88.1	-43.5	64.7	449.2	-
Net Income		153.0	151.8	244.8	260.8	262.1	-177.6	-113.1	102.3	-1,258.5	-758.4

- Notes:
1. Fractions smaller than 0.1 billion yen are rounded down.
 2. Since FY2006, the "nuclear power back-end cost" (reprocessing costs of irradiated nuclear fuel, costs for preparation of reprocessing of irradiated nuclear fuel, disposal costs of high-level radioactive wastes, decommissioning costs of nuclear power units) included with "Other" has been described separately.

5. Consolidated Statements of Cash Flow

(Unit: billion yen)

FY	2002	2003	2004	2005	2006	2007	2008	2009	2010	2011
Cash flows from operating activities:										
Income before income taxes and minority interest	265.1	255.3	372.8	473.8	496.0	-212.4	-99.5	223.4	-766.1	-753.7
Depreciation and amortization	922.3	889.9	847.5	824.0	751.6	772.4	757.0	759.3	702.1	686.5
Decommissioning costs of nuclear power units	-	-	-	-	-	-	-	-	20.8	6.9
Loss on impairment of fixed assets	-	44.8	-	-	-	-	12.2	-	-	-
Loss on nuclear fuel	48.2	20.1	47.3	49.6	55.5	33.4	31.6	37.1	39.5	12.3
Loss on disposal of property plant and equipment	32.8	32.4	33.2	34.1	45.3	24.0	23.1	22.9	29.1	33.7
Extraordinary loss on disaster	-	-	-	-	-	-	-	-	1,020.4	-
Loss of Adjustment based on the accounting standard for asset retirement obligations	-	-	-	-	-	-	-	-	57.1	-
Increase/decrease in provision for accrued employees' retirement benefits (*1)	63.7	-66.1	-39.2	-65.6	3.7	-14.4	-0.8	-7.4	11.8	0.0
Provision for reprocessing of irradiated nuclear fuel	65.6	22.8	111.7	-	-	-	-	-	-	-
Increase/decrease in reserve for reprocessing of irradiated nuclear fuel (*1)	-	-	-	9.6	17.5	-32.1	-15.8	-17.6	-17.2	-30.0
Increase/decrease in reserve for future reprocessing of irradiated nuclear fuel (*1)	-	-	-	17.9	2.6	6.4	9.3	8.6	-	3.3
Increase/decrease in provision for decommissioning costs of nuclear power units (*1)	15.6	1.6	3.5	21.3	16.5	82.1	16.2	18.5	-	-
Increase/decrease in reserve for casualty loss from natural disaster(*1)	-	-	-	-	-	164.5	3.6	-75.3	-36.3	285.1
Interest revenue and dividends received	-8.8	-8.3	-9.7	-11.1	-19.0	-29.3	-31.2	-27.8	-30.9	-29.2
Interest expense	206.7	170.4	164.5	161.3	154.7	149.3	140.1	134.0	127.9	129.9
Gain on exchange of stock due to merger of subsidiary removed from consolidation	-	-	-	-51.1	-	-	-	-	-	-
Gain on business transfer	-	-	-	-	-60.7	-	-	-	-	-
Investment gain or loss under the equity method (* ² denotes investment gain)	-	-	-	-	-	-	-13.8	-12.6	-16.0	6.4
Grants-in-aid from Nuclear Damage Liability Facilitation Fund	-	-	-	-	-	-	-	-	-	-2,426.2
Compensation for nuclear damages	-	-	-	-	-	-	-	-	-	2,324.9
Gain on sales of noncurrent assets	-	-	-	-	-	-	-	-	-	-41.6
Gain on sales of securities	-	-	-	-	-	-	-	-	-	-28.8
Loss on sales of securities	-	-	-	-	-	-	-	-	-	40.4
Gain on sales of subsidiaries and affiliates' stocks	-	-	-	-	-	-	-	-	-	-20.1
Loss on sales of stocks of subsidiaries and affiliates	-	-	-	-	-	-	-	-	-	4.7
Increase/decrease in reverse fund for reprocessing of irradiated nuclear fuel (*2)	-	-	-	-262.2	-84.2	-171.4	-149.5	-156.9	-158.2	-143.3
Increase/decrease in long-term prepaid expenses (*2)	-	-	-	-	-	-105.4	61.5	-	-	-
Increase/decrease in trade receivables (*2)	32.9	11.3	-12.2	-18.1	-24.4	-7.5	-42.8	81.0	-11.5	-74.5
Increase/decrease in inventory assets (*2)	-	-	-	-	-	-	19.1	-	-	-
Increase/decrease in accounts payable (*1)	91.7	19.0	38.8	91.8	33.2	235.9	-114.0	66.9	-5.8	91.7
Other	24.3	25.2	121.0	-2.2	-31.1	-31.4	36.9	55.4	132.9	-140.4
Total	1,760.5	1,418.8	1,679.4	1,255.2	1,372.6	860.3	640.2	1,110.6	1,108.3	137.9
Receipt of interest and cash dividends										
Interest paid	4.2	4.6	8.2	6.8	14.3	23.9	27.8	29.3	31.4	20.7
Payments for loss on disaster due to the Tohoku-Chihou-Taiheiyou-Oki Earthquake	-217.3	-175.0	-165.3	-163.8	-157.7	-150.5	-141.4	-137.8	-128.1	-128.6
Receipts of Grants-in-aid from Nuclear Damage Liability Facilitation Fund	-	-	-	-	-	-	-	-	-	-234.5
Receipt of compensation based on the Contract for Indemnification of Nuclear Damage Compensation	-	-	-	-	-	-	-	-	-	663.6
Payments for nuclear damage compensation	-	-	-	-	-	-	-	-	-	120.0
Income taxes paid or refund (* ³ denotes tax paid)	-141.1	-100.8	-110.8	-162.6	-155.6	-223.8	72.4	-13.8	-23.0	-15.7
Net cash provided by operating activities	1,406.3	1,147.5	1,411.4	935.6	1,073.6	509.8	599.1	988.2	988.7	-2.8
Cash flows from investing activities:										
Purchase of property, plant and equipment	-828.2	-659.8	-561.4	-618.4	-544.1	-671.0	-661.4	-633.6	-661.8	-730.3
Proceeds from sales of noncurrent assets	-	-	-	-	-	-	-	-	-	54.4
Receipt of contributions in aid of construction	27.5	13.6	16.6	10.9	25.1	19.0	12.4	25.6	15.9	11.9
Increase in investments	-38.3	-22.1	-21.5	-16.8	-32.1	-57.8	-17.7	-52.1	-358.0	-23.9
Proceeds from investments	2.0	2.0	31.2	21.3	23.6	6.9	29.9	12.8	217.7	352.5
Payments for purchases of subsidiaries net of cash acquired	-	-17.4	-30.7	-14.3	-	-0.9	-0.9	-	-	-
Proceeds from purchases of subsidiaries net of cash paid	-	9.5	0.4	-	0.1	2.3	-	-	-	-
Payments for sale of subsidiaries stocks	-	-	-	-	-	-0.8	-	-	-	-
Proceeds from sale of subsidiaries stocks	-	-	-	-	-	3.4	-	-	-	-
Decrease due to merger of certain subsidiaries with an exclusion	-	-	-	-44.9	-	-	-	-	-	-
Proceeds from sale of equity in subsidiaries	-	-	-	-	0.9	-	-	-	-	-
Decrease due to disposal of consolidated subsidiaries	-	-	-	-	-	-0.3	-	-	-	-
Decrease due to business transfer	-	-	-	-	-3.9	-	-	-	-	-
Proceeds from sale of subsidiaries	-	-	-	-	-	-	-	37.6	-	-
Other	-26.7	-19.5	-11.9	46.9	-19.8	12.7	-17.5	10.4	-5.7	0.1
Net cash used in investing activities	-863.7	-693.8	-577.5	-615.3	-550.1	-686.2	-655.3	-599.2	-791.9	-335.1
Cash flows from Financing Activities:										
Proceeds from issuance of bonds	800.8	534.5	252.1	249.1	327.9	747.7	668.0	239.3	234.2	-
Redemption of bonds	-710.3	-462.5	-124.3	-405.9	-729.0	-693.3	-598.0	-427.8	-430.2	-548.9
Proceeds from long-term loans	87.5	147.6	96.4	98.0	194.7	426.9	540.4	322.0	2,076.6	126.0
Repayment of long-term loans	-549.8	-393.3	-432.1	-315.7	-361.0	-252.7	-282.0	-356.1	-357.3	-218.3
Proceeds from short-term loans	1,447.4	1,377.4	1,075.8	906.5	834.2	815.3	850.5	721.8	744.7	989.3
Repayment of short-term loans	-1,375.2	-1,563.2	-1,215.5	-935.8	-823.8	-788.5	-851.2	-749.7	-701.8	-952.6
Proceeds from issuance of commercial paper	2,024.0	2,299.0	1,365.0	1,020.0	889.0	1,487.0	1,555.0	730.0	40.0	-
Redemption of commercial paper	-2,216.0	-2,309.0	-1,720.0	-885.0	-764.0	-1,452.0	-1,615.0	-900.0	-105.0	-
Proceeds from issuance of common stock	-	-	-	-	-	-	-	-	446.8	-
Proceeds paid	-80.9	-80.9	-80.9	-80.8	-80.9	-101.0	-80.9	-80.8	-80.8	-
Other	-1.1	-1.0	-2.0	-0.4	-2.0	-1.2	-1.3	6.1	-7.7	-10.2
Net cash used in financing activities	-573.7	-451.3	-785.6	-350.1	-514.8	188.2	194.4	-495.0	1,859.5	-614.7
Effect of exchange rate changes on cash and cash equivalents	0.9	-2.0	0.6	2.2	0.4	-0.6	-4.6	0.4	-3.2	0.3
Net increase/decrease in cash and cash equivalents (*1)	-30.3	0.3	48.9	-27.6	9.1	11.2	133.5	-105.5	2,053.1	-952.3
Cash and cash equivalents at beginning of the year	113.4	83.1	83.4	132.4	104.7	113.9	125.1	258.7	153.1	2,206.2
Cash and cash equivalents at end of the year	83.1	83.4	132.4	104.7	113.9	125.1	258.7	153.1	2,206.2	1,253.8

*1: "-" denotes a decrease

*2: "-" denotes an increase

Notes: 1. Fractions smaller than 0.1 billion yen are rounded down.
2. For FY2011 consolidated accounting, "Proceeds from sales of noncurrent assets" have been listed separately due to their increased financial importance.

6. Changes in Ordinary Income

(1) Non-Consolidated

(Unit: billion yen)

FY1975	First half	32.3	FY1992	158.3
	Second half	33.7	FY1993	159.9
FY1976	First half	35.3	FY1994	208.9
	Second half	68.3	FY1995	167.5
FY1977	First half	69.5	FY1996	142.5
	Second half	78.3	FY1997	217.3
FY1978		167.4	FY1998	207.9
FY1979		-27.4	FY1999	345.9
FY1980		274.5	FY2000	320.0
FY1981		94.4	FY2001	319.5
FY1982		195.4	FY2002	280.8
FY1983		256.8	FY2003	304.4
FY1984		217.9	FY2004	384.5
FY1985		343.9	FY2005	397.2
FY1986		444.0	FY2006	372.0
FY1987		341.8	FY2007	-22.0
FY1988		275.3	FY2008	-90.1
FY1989		184.9	FY2009	158.6
FY1990		128.2	FY2010	271.0
FY1991		146.8	FY2011	-408.3

(2) Consolidated

(Unit: billion yen)

FY1994	212.0	FY2003	307.7
FY1995	169.2	FY2004	408.2
FY1996	146.5	FY2005	426.9
FY1997	222.3	FY2006	441.2
FY1998	219.2	FY2007	33.1
FY1999	350.0	FY2008	-34.6
FY2000	330.9	FY2009	204.3
FY2001	342.8	FY2010	317.6
FY2002	271.1	FY2011	-400.4

7. Changes in Capital

(Unit: 1,000 yen)

Date	Increased Capital	Capital	Remarks
May 1, 1951		1,460,000	Incorporation
Dec. 15, 1952	2,920,000	4,380,000	1 : 2 paid-in capital increase
Jan. 31, 1953	1,460,000	5,840,000	3 : 1 gratis capital increase
Dec. 19, 1953	2,920,000	8,760,000	2 : 1 paid-in and gratis combined capital increase
Dec. 13, 1954	4,380,000	13,140,000	2 : 1 paid-in and gratis combined capital increase
Oct. 1, 1957	6,860,000	20,000,000	2 : 1 paid-in and gratis combined capital increase 580,000 shares: public offering
Oct. 1, 1958	10,000,000	30,000,000	2 : 1 paid-in and gratis combined capital increase
Oct. 1, 1959	15,000,000	45,000,000	2 : 1 paid-in and gratis combined capital increase
Oct. 1, 1960	15,000,000	60,000,000	3 : 1 paid-in and gratis combined capital increase
Oct. 16, 1961	30,000,000	90,000,000	2 : 1 paid-in and gratis combined capital increase
Apr. 1, 1963	30,000,000	120,000,000	3 : 1 paid-in and gratis combined capital increase
Apr. 1, 1966	30,000,000	150,000,000	4 : 1 paid-in and gratis combined capital increase
Jul. 2, 1968	37,500,000	187,500,000	4 : 1 paid-in and gratis combined capital increase
Jul. 2, 1970	46,875,000	234,375,000	4 : 1 paid-in and gratis combined capital increase
Sep. 11, 1972	9,375,000	243,750,000	Partial credit of the reserve for revaluation of assets to stated stock
Mar. 30, 1973	56,250,000	300,000,000	5 : 1 paid-in and gratis combined capital increase 37,500,000 shares: public offering
Jun. 16, 1974	3,000,000	303,000,000	1 : 0.01 gratis capital increase
Dec. 13, 1974	3,030,000	306,030,000	1 : 0.01 gratis capital increase
Jun. 17, 1975	3,060,300	309,090,300	1 : 0.01 gratis capital increase
Jul. 2, 1975	91,809,000	400,899,300	1 : 0.3 paid-in and gratis combined capital increase
Jul. 15, 1976	4,008,993	404,908,293	1 : 0.01 gratis capital increase
Oct. 1, 1976	1,707	404,910,000	3,414 shares: public offering (fractions adjusted)
Jan. 14, 1977	4,049,100	408,959,100	1 : 0.01 gratis capital increase
Jul. 2, 1978	101,040,900	510,000,000	1 : 0.2 paid-in capital increase 38,498,160 shares: public offering
Jul. 13, 1980	10,200,000	520,200,000	1 : 0.02 gratis capital increase
Oct. 1, 1981	129,800,000	650,000,000	1 : 0.2 paid-in capital increase 51,520,000 shares: public offering
Nov. 20, 1986	6,500,000	656,500,000	1 : 0.01 gratis capital increase
Mar. 1, 1989 - Mar. 31, 1989	496	656,500,496	Conversions of convertible bonds
Apr. 1, 1989 - Mar. 31, 1990	611,977	657,112,473	Conversions of convertible bonds
Apr. 1, 1990 - May 21, 1990	37,995	657,150,469	Conversions of convertible bonds
May 22, 1990	13,131,628	670,282,097	1 : 0.02 gratis capital increase
May 22, 1990 - Mar. 31, 1991	128,486	670,410,584	Conversions of convertible bonds
Apr. 1, 1991 - Mar. 31, 1992	3,991	670,414,576	Conversions of convertible bonds
Apr. 1, 1993 - Mar. 31, 1994	497	670,415,073	Conversions of convertible bonds
Apr. 1, 1994 - Mar. 31, 1995	497	670,415,571	Conversions of convertible bonds
Nov. 20, 1995	6,018,125	676,433,697	Partial credit of the capital reserve to stated stock
Apr. 1, 2000 - Mar. 31, 2001	500	676,434,197	1 → 1.01 stock split (partial gratis capital increase) Conversions of convertible bonds
Oct. 19, 2010	201,111,105	877,545,302	227,630,000 shares: public offering
Nov. 1, 2010	23,430,420	900,975,722	26,520,000 shares: third party allotment
Jul. 31, 2012	1,000,000,000	1,400,975,722	1,940,000,000 shares: third party allotment (1,600,000,000 shares: class A preferred shares) (340,000,000 shares: class B preferred shares)

Note: The above way of indicating a capital increase ratio is in compliance with the directions from the Tokyo Stock Exchange started in 1974.

8. Changes in Number of Shareholders and Shares (including shareholders and shares less than one unit)

At the End of FY	1951	1955	1965	1975	1985	1990	1995	2000	2004	2005	2006	2007	2008	2009	2010	2011
Total Number of Shareholders (persons)	86,538	107,508	201,853	353,853	384,401	760,579	860,249	817,810	821,841	801,025	757,030	811,725	793,488	794,653	933,031	898,831
Individual Shareholders (persons) (Ratio, %)	85,506 (98.8)	105,448 (98.1)	199,118 (98.6)	351,103 (99.2)	380,157 (98.9)	751,212 (98.8)	851,756 (99.0)	810,991 (99.2)	815,679 (99.3)	794,956 (99.2)	751,185 (99.2)	805,673 (99.3)	787,440 (99.2)	788,842 (99.3)	926,153 (99.3)	892,589 (99.3)
Total Number of Shares (in 10 thousand shares)	292	2,628	24,000	80,179	130,000	133,947	135,286	135,286	135,286	135,286	135,286	135,286	135,286	135,286	160,701	160,701
Shares Owned by Individual Shareholders (in 10 thousand shares) (Ratio, %)	126 (43.4)	1,363 (51.9)	9,082 (37.8)	33,303 (41.5)	38,907 (29.9)	43,787 (32.7)	48,169 (35.6)	46,778 (34.6)	51,358 (38.0)	49,796 (36.8)	45,009 (33.3)	49,756 (36.8)	48,936 (36.2)	51,235 (37.9)	70,269 (43.7)	85,767 (53.4)
Capital (billion yen)	1.4	13.1	120.0	400.8	650.0	670.4	676.4	676.4	676.4	676.4	676.4	676.4	676.4	676.4	900.9	900.9

<Reference> Comparison with Other Industries as Ratio of Individual Shareholders and Ratio of Individual Stock Ownership (per unit)

(as of the end of March 2012)

Branches of Industry (all listed companies)	Ratio of Individual Shareholders (%)	Ratio of Individual Stock Ownership (%)
TEPCO	99.3	53.2
Iron and Steel	98.0	22.0
Machinery	97.1	28.0
All Industries	97.3	29.1

Note: The figures for other industries were taken from the report of "FY2010 Share-ownership Survey" (conducted jointly by the Tokyo Stock Exchange and other organizations).

<Reference> Current Distribution of Shares (per unit) by Owners

(as of the end of March 2012)

	Central and Local Governments	Domestic Corporations	Foreign Corporations, etc.	Individuals and Others	Total
Number of Shareholders (persons) (Ratio, %)	32 (0.0)	3,915 (0.6)	942 (0.1)	693,839 (99.3)	698,728 (100.0)
Number of Shares Held (in hundred shares) (Ratio, %)	434,360 (2.7)	4,487,241 (28.0)	2,541,491 (15.9)	8,538,162 (53.4)	16,001,254 (100.0)

<Reference> Major Shareholders (top 10 shareholders)

(as of the end of March 2012)

Shareholder Name	Number of Shares Held (in thousand share units)	Equity Share (%)
Tokyo Metropolitan Government	42,676	2.66
TEPCO Employees' Stock Sharing Organization	38,398	2.39
Sumitomo Mitsui Banking Corp.	35,927	2.24
The Dai-ichi Life Insurance Company, Limited	35,600	2.22
Nippon Life Insurance Co.	35,200	2.19
The Master Trust Bank of Japan , Ltd. (Shintaku account)	29,802	1.85
Japan Trustee Services Bank, Ltd. (Shintaku account)	27,770	1.73
Mizuho Corporate Bank, Ltd.	23,791	1.48
SSBT OD05 OMNIBUS ACCOUNT - TREATY CLIENTS	17,935	1.12
STATE STREET BANK WEST CLIENT - TREATY	12,458	0.78
Total	299,561	18.64

Note: Fractions smaller than one thousand shares are rounded down.

9. Changes in Shareholders' Equity Ratio

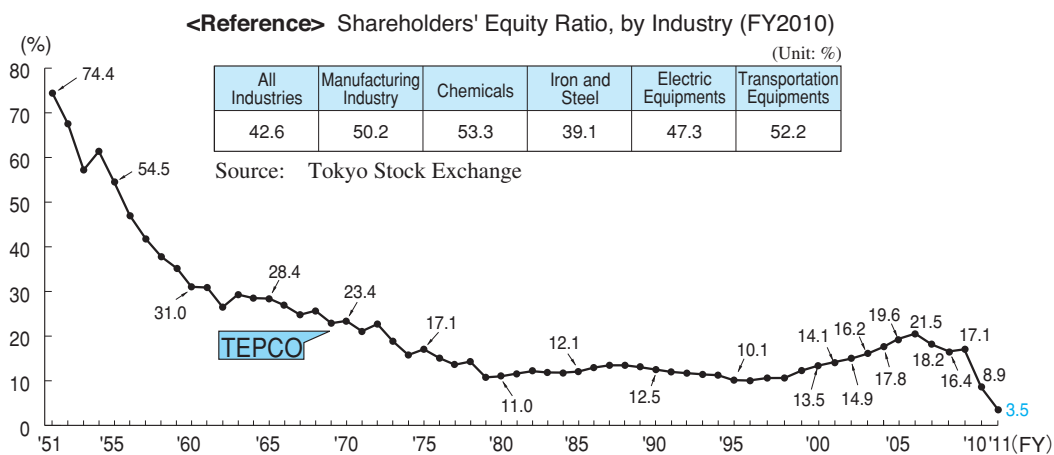

10. Changes in Ratio of Recurring Profit to Capital Stock

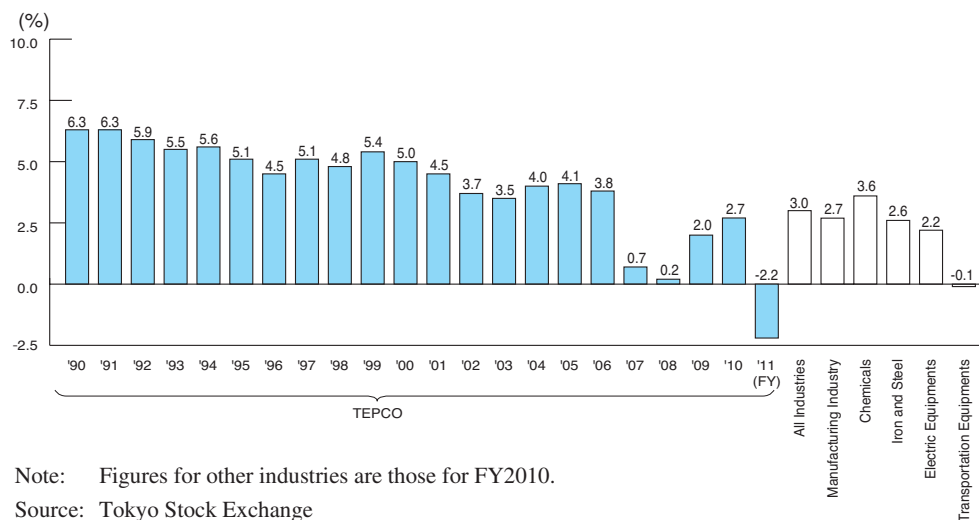

Note: Figures for other industries are those for FY2010.

Source: Tokyo Stock Exchange

11. Changes in Costs of Supplying Electricity

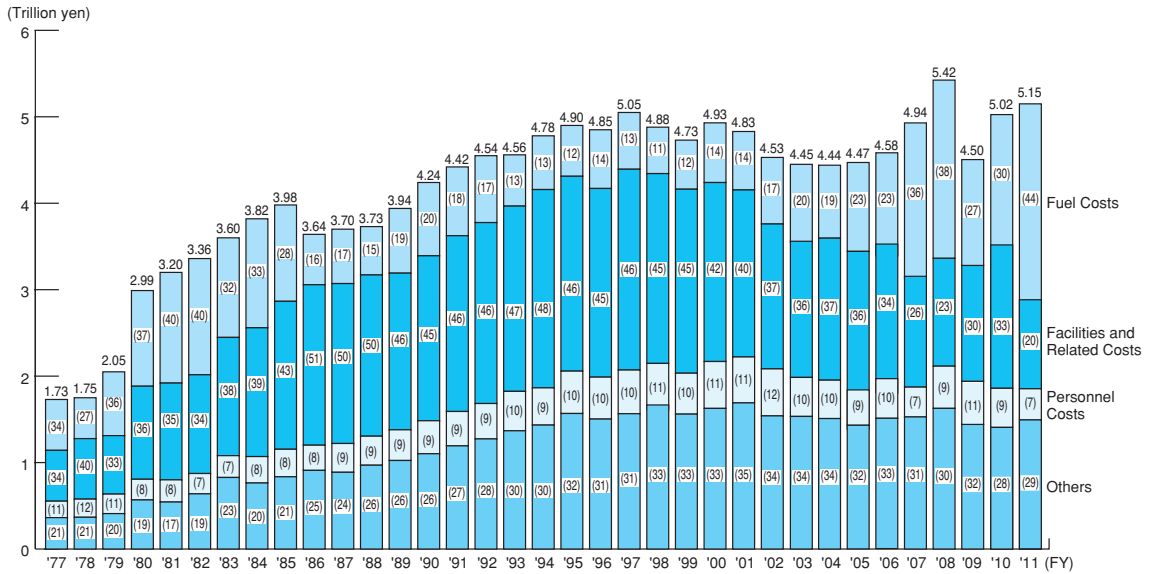

- Notes:
- "Facilities and related costs" means the sum of maintenance expenses, depreciation expenses, interest expenses, and funds for dividends.
 - Figures in parentheses show the percentage composition (%).
 - Due to changes in the Accounting Rule for Electricity Business, depreciation expenses for trial operation has been classified as "Facilities and related costs" and separated from "Others" since FY1996.
 - "Others" includes purchased electricity, rent expenses fees, expenditure for agential tasks, property tax, promotion of power resources development tax, enterprise tax, etc.

<Reference> Changes in Equipment Expenses and Fuel Costs per kWh of Electricity Sales

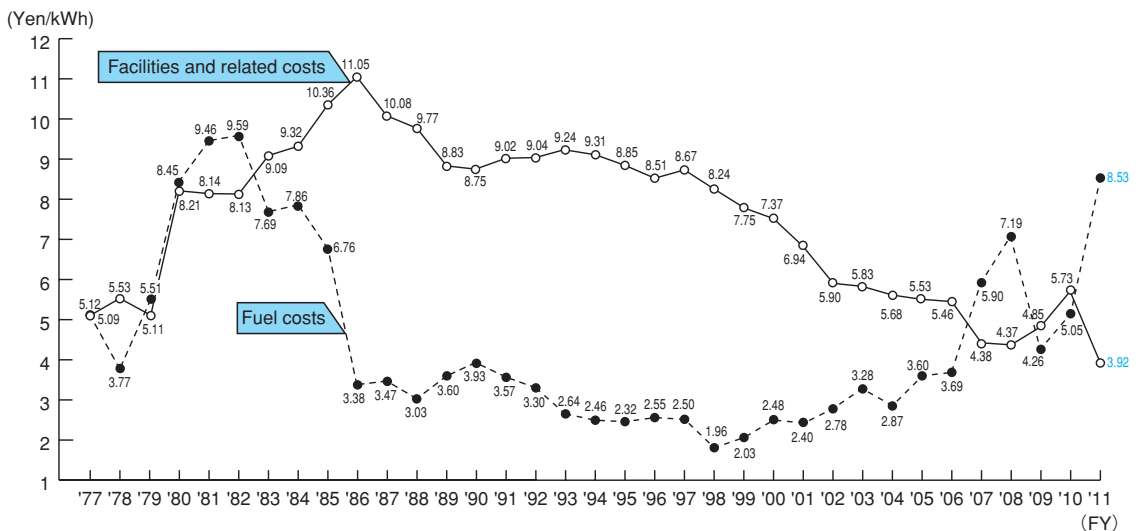

<Reference> Changes in Exchange Rate (Interbank Monthly Average)

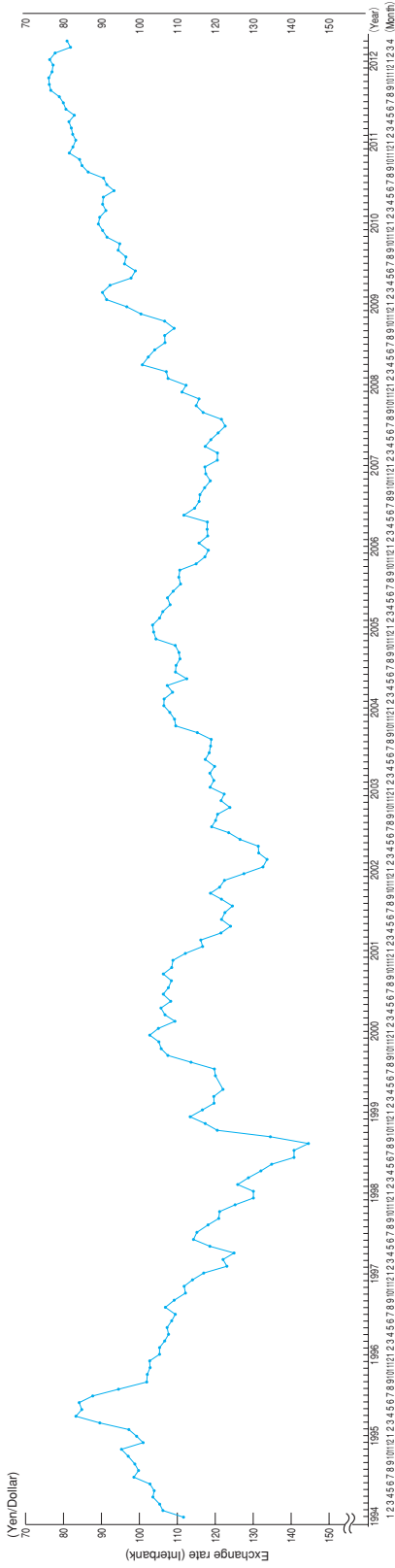

<Reference> Annual Exchange Rate (Interbank)

FY	'71	'72	'73	'74	'75	'76	'77	'78	'79	'80	'81	'82	'83	'84	'85	'86	'87	'88	'89	'90	'91
Exchange rate (Yen/Dollar)	317	299	273	293	299	292	257	202	230	217	228	250	236	244	221	160	138	128	143	141	133
FY	'92	'93	'94	'95	'96	'97	'98	'99	'00	'01	'02	'03	'04	'05	'06	'07	'08	'09	'10	'11	
Exchange rate (Yen/Dollar)	125	108	99	96	113	123	128	112	111	125	122	113	108	113	117	114	101	93	86	79	

Note: For FY1971, the average value in the second half of the year is indicated because a fixed exchange rate system was adopted by August 27 of this year.

VIII. Electricity Rates and Rate Systems

1. Electricity Rates

(1) Overall Electricity Rates for Residential and Power Services

(Unit: yen/kWh)

FY	'75	'76	'77	'78	'79	'80	'81
Residential	15.85	17.67	19.17	18.44	19.36	28.12	28.74
Power	10.91	12.19	13.39	12.63	13.48	21.70	22.16
Total	12.22	13.61	14.90	14.17	15.01	23.38	23.90
FY	'82	'83	'84	'85	'86	'87	'88
Residential	28.80	28.99	29.13	29.25	27.03	25.74	25.20
Power	22.40	22.42	22.43	22.60	20.57	18.95	17.98
Total	24.10	24.18	24.21	24.38	22.31	20.79	19.94
FY	'89	'90	'91	'92	'93	'94	'95
Residential	24.70	24.78	24.86	24.93	24.80	24.68	24.52
Power	17.33	17.28	17.46	17.69	17.64	17.17	17.02
Total	19.35	19.34	19.53	19.77	19.73	19.40	19.28
FY	'96	'97	'98	'99	'00	'01	'02
Residential	24.28	24.68	23.65	23.33	23.50	23.36	21.89
Power	16.75	16.98	16.15	18.13	18.14	18.04	16.22
Total	18.99	19.27	18.43	20.34	20.41	20.30	18.68
FY	'03	'04	'05	'06	'07	'08	'09
Residential	21.97	21.35	21.25	21.28	21.48	22.98	20.90
Power	16.30	15.70	22.03	23.27	23.18	25.35	23.53
Total	18.74	18.17	21.34	21.52	21.67	23.24	21.18
FY	'10	'11					
Residential	20.96	22.27					
Power	22.62	24.61					
Total	21.14	22.51					

Notes:

- Overall electricity rate =
$$\frac{\text{Revenue from electricity sales} - \text{Additional charges due to the delayed payment}}{\text{Electricity sales} - \text{Amount of electric power used for business operations and construction work}}$$
- Figures after FY1999 exclude specified-scale demand.
- Figures after 2010 include Photovoltaic Power Promotion Surcharge.

(2) Electricity Rates Revision History

Subject Companies	Date Effected	Rate of Adjustment (%)	Change Factors
9 power companies	August 13, 1951	Average 30.1 (Tokyo 24.0)	Result of rising price of goods and increased capital expenses because of first asset re-evaluation
9 power companies	May 11, 1952	Average 28.0 (Tokyo 24.2)	Result of rising price of goods and increased capital expenses because of second asset re-evaluation
9 power companies	October 1, 1954	Average 11.2 (Tokyo 11.6)	Result of increased capital expenses from power development because of third asset re-evaluation
Tohoku Electric Power Hokuriku Electric Power	July 14, 1957	Tohoku 17.8 Hokuriku 18.14	Result of increased capital expenses from power development
Kyushu Electric Power	March 21, 1961	10.5	Result of increased capital expenses from power development and poor balance of accounts after suspension of hydroelectric and thermal power adjustment fund
TEPCO	August 5, 1961	13.7	Result of increased capital expenses from power development and expansion and strengthening of transmission / distribution equipment, and rising fuel costs
Tohoku Electric Power	December 1, 1962	12.63	Result of increased capital expenses from power development and rising fuel costs and purchased power costs
Chubu Electric Power	April 1, 1965	7.89	Result of increased capital expenses from power development and rising fuel costs
Hokuriku Electric Power	August 9, 1966	6.38	Result of increased capital expenses from power development
Chugoku Electric Power	October 15, 1966	-3.91	Result of rate gap correction after management streamlining
Shikoku Electric Power Kansai Electric Power	September 29, 1973	Shikoku 17.75 Kansai 22.23	Result of increased investment for pollution prevention and environmental mitigation, spike in fuel costs, soaring price of various goods, increased capital expenses during power development
9 power companies	June 1, 1974	Average 56.82 (Tokyo 63.04)	Result of soaring fuel costs, costs of environmental measures and increased capital expenses from power supply equipment expansion, and soaring price of various goods
4 power companies	June 26, 1976	Hokkaido 30.33 Tohoku 28.47 Hokuriku 26.06 Kyushu 24.84	Result of increased capital expenses from soaring fuel costs and soaring price of various goods
Kansai Electric Power	August 10, 1976	22.22	"
4 power companies	August 31, 1976	Tokyo 21.01 Chubu 22.47 Chugoku 22.19 Shikoku 22.81	"
Hokkaido Electric Power	February 12, 1980	34.23	Result of soaring fuel costs and increased capital expenses
8 power companies	April 1, 1980	Average 50.83 (Tokyo 52.33) (excluding Hokkaido)	"
Hokkaido Electric Power	October 1, 1981	18.11	"
10 power companies	January 1, 1988	Average for 9 power companies -17.83 (Tokyo -19.16)	Result of reduction of fuel costs
10 power companies	April 1, 1989	Average -2.96 (Tokyo -3.11)	Revision of base price with implementation of consumption tax
10 power companies	January 1, 1996	Average -6.29 (Tokyo -5.39)	Reduction of base price based on management efficiency initiative results and outlook
10 power companies	February 10, 1998	Average -4.67 (Tokyo -4.20)	"
10 power companies	October 1, 2000	Average -5.42 (Tokyo -5.32)	"
TEPCO	April 1, 2002	-7.02	"
Tohoku Electric Power	July 1, 2002	-7.10	"
Chubu Electric Power	September 1, 2002	-6.18	"
7 power companies	October 1, 2002	Hokkaido -5.39 Hokuriku -5.32 Kansai -5.35 Chugoku -5.72 Shikoku -5.22 Kyushu -5.21 Okinawa -5.79	"
TEPCO	October 1, 2004	-5.21	"
3 power companies	January 1, 2005	Tohoku -4.23 Chubu -5.94 Kyushu -5.46	"
5 power companies	April 1, 2005	Hokkaido -4.04 Hokuriku -4.05 Kansai -4.53 Chugoku -3.53 Shikoku -4.23	"
Okinawa Electric Power	July 1, 2005	-3.27	"

Subject Companies	Date Effected	Rate of Adjustment (%)	Change Factors
4 power companies	April 1, 2006	Tokyo -4.01 Kansai -2.91 Chubu -3.79 Kyushu -3.71	Reduction of base price based on management efficiency initiative results and outlook
6 power companies	July 1, 2006	Hokkaido -2.85 Tohoku -3.05 Hokuriku -2.65 Chugoku -2.51 Shikoku -2.57 Okinawa -3.24	"
Hokuriku Electric Power	March 1, 2008	-	Revision of wheeling charge
Chubu Electric Power	April 1, 2008	-	Reduction of base price based on management efficiency initiative results and outlook
8 power companies	September 1, 2008	Hokkaido - Tohoku - Tokyo - Kansai - Chugoku -1.00 Shikoku - Kyushu -1.18 Okinawa -0.45	Revision of electricity rates as a result of soaring fuel costs and reduction of base price based on management efficiency initiative results and outlook
TEPCO	September 1, 2012	8.46	Result of increased fuel costs because of the outage of nuclear power plants, etc.

(Reference Data)

8 power companies	October 1978 - March 1979	Average drop in unit price 1.35 yen (Tokyo 1.65 yen) (Exc. Hokkaido)	Temporary rate reduction measures following high yen
10 power companies	June 1986 - December 1986	Average drop in unit price for 9 power companies 2.20 yen (Tokyo 2.39 yen)	Temporary rate reduction following high yen, drop in crude oil prices, etc.
10 power companies	January 1987 - December 1987	Average drop in unit price for 9 power companies 3.10 yen (Tokyo 3.50 yen)	"
10 power companies	November 1993 - September 1994	Average drop in unit price 0.35 yen (Tokyo 0.37 yen)	Temporary rate reduction measures following high yen, etc.
10 power companies	October 1994 - June 1995	Average drop in unit price 0.35 yen (Tokyo 0.37 yen)	"
10 power companies	July 1995 to time of rate changes	Average drop in unit price 0.40 yen (Tokyo 0.42 yen)	Temporary rate reduction measures following high yen, etc. (expansion continuing)

(3) Unit Price of Electricity (become effective on September 1, 2012)

○ Lighting [by electric supply contract]

Fixed Rate Lighting Service				Temporary Lighting Service							
Contract Category		Unit	Rate (Yen) [Inc. tax]	Contract Category		Unit	Rate (Yen) [Inc. tax]				
Fixed Rate Lighting Service	Lamp charge	Customer charge	per contract	52.50	A	Up to 50 VA	per contract per day	7.67			
		Up to 10 W	per lamp	94.71		Over 50 VA to 100 VA	"	15.32			
		Over 10 W to 20 W	"	142.17		For every 100 VA over 100 VA up to 500 VA	"	15.32			
		Over 20 W to 40 W	"	237.09		Over 500 VA to 1 kVA	"	153.21			
		Over 40 W to 60 W	"	332.01		For every 1 kVA over 1 kVA up to 3 kVA	"	153.21			
		Over 60 W to 100 W	"	521.85	B	Demand charge	10A	300.30			
		For every 100 W over 1st 100 W	"	521.85		Energy charge	1kWh	32.00			
	Small appliance charge	Up to 50 VA	per appliance	227.33	C	Demand charge	1kVA	300.30			
		Over 50 VA to 100 VA	"	367.50		Energy charge	1kWh	32.00			
		For every 100 VA over 1st 100 VA	"	367.50	Customer charge	per contract	47.25				
Meter-Rate Lighting Service	A	Minimum charge	up to 1st 8 kWh	224.45	Public Street Lighting Service	A	Lamp charge	Up to 10 W	per lamp	85.68	
		Energy charge	per kWh over 1st 8 kWh	18.89				Over 10 W to 20 W	"	129.36	
	B	Demand charge	10A	per contract				273.00	Over 20 W to 40 W	"	216.72
			15A	"				409.50	Over 40 W to 60 W	"	304.08
			20A	"				546.00	Over 60 W to 100 W	"	478.80
			30A	"		819.00	For every 100 W over 1st 100 W	"	478.80		
			40A	"		1,092.00	Small appliance charge	Up to 50 VA	per appliance	207.38	
	50A	"	1,365.00	Over 50 VA to 100 VA		"		331.80			
	60A	"	1,638.00	For every 100 VA over 1st 100 VA		"		331.80			
	Energy charge	Up to 1st 120 kWh (1st block rate)	1kWh	18.89		B	Demand charge	1kVA	246.75		
		Over 120 kWh to 300 kWh (2nd block rate)	"	25.19	Energy charge		1kWh	19.06			
		Over 300 kWh (3rd block rate)	"	29.10	Minimum monthly charge		per contract	213.95			
	Minimum monthly charge		per contract	224.45							
	C	Energy charge	Demand charge	1kVA	273.00						
			Up to 1st 120 kWh (1st block rate)	1kWh	18.89						
			Over 120 kWh to 300 kWh (2nd block rate)	"	25.19						
			Over 300 kWh (3rd block rate)	"	29.10						

○ Power [by electricity supply contract]

Contract Category		Unit	Rate (Yen) [Inc. tax]		
Low-Voltage Power Service	Demand charge	1kW	1,071.00		
	Energy charge	1kWh	Summer 16.50	Other seasons 14.99	
Temporary Power Service	Fixed rate service	1kW Per day	180.42		
	Meter-Rate Service	Demand charge	1kW	20% higher than ordinary supply rate	
		Energy charge	1kWh	Summer 19.79	Other seasons 18.00
Agricultural Power Service (for agricultural irrigation purposes)	Demand charge	1kW	420.00		
	Energy charge	1kWh	Summer 12.44	Other seasons 11.31	

* For Low-Voltage Power, Temporary Power and Agricultural Power Service, "summer" means a period from July 1 through September 30 each year and "other seasons" means a period from October 1 each year through June 30 next year.

○ Major Optional Rules for Supply of Electricity

Contract category			Unit	Rate (¥) [including tax]	
Otokuna-Night 8 (Time-Specific Lighting [8-Hour Night Service])	Demand charge	For 6 kVA or less	per contract	1,260.00	
		For 7 kVA - 10 kVA	"	2,100.00	
		For 11 kVA and over	"	¥2,100.00 + ¥273.00 × (Contract capacity - 10kVA)	
	Energy charge	Day hours	Up to 1st 90 kWh (1st block rate)	1kWh	23.15
			Over 90 kWh to 230 kWh (2nd block rate)	"	30.87
			Over 230 kWh (3rd block rate)	"	35.66
		Night hours	"	11.82	
	Discount	per 1 kVA for total capacity of 5-hour-auto-shutoff appliances		Discount of 241.50 yen	
		per 1 kVA for total capacity where auto-shutoff nighttime thermal storage type appliances are used		Discount of 147.00 yen	
	Minimum monthly charge			per contract	314.75
Otokuna-Night 10 (Time-Specific Lighting [10-Hour Night Service])	Demand charge	For 6 kVA or less	per contract	1,260.00	
		For 7 kVA - 10 kVA	"	2,100.00	
		For 11 kVA and over	"	¥ 2,100.00 + ¥ 273.00 × (Contract capacity - 10kVA)	
	Energy charge	Day hours	Up to 1st 80 kWh (1st block rate)	1kWh	25.20
			Over 80 kWh to 200 kWh (2nd block rate)	"	33.60
			Over 200 kWh (3rd block rate)	"	38.81
		Night hours	"	12.06	
	Discount	per 1 kVA for total capacity of 8-hour-auto-shutoff appliances		Discount of 42.00 yen	
		per 1 kVA for total capacity of 5-hour-auto-shutoff appliances		Discount of 283.50 yen	
		per 1 kVA for total capacity where auto-shutoff nighttime thermal storage type appliances are used		Discount of 189.00 yen	
Minimum monthly charge			per contract	314.75	

* For the "Otokuna-Night 8"(Time-Specific Lighting [8-Hour Night Service]), "day hours" refers to the time period from 7:00 a.m. to 11:00 p.m. every day and "night hours" refers to the time period from 11:00 p.m. to 7:00 a.m. of the next day.

* For the "Otokuna-Night 10"(Time-Specific Lighting [10-Hour Night Service]), "day hours" refers to the time period from 8:00 a.m. to 10:00 p.m. every day and "night hours" refers to the time period from 10:00 p.m. to 8:00 a.m. of the next day.

* From March 31, 2013, we will no longer accept applications for the 5-hour auto-shutoff appliance discount.

Contract category			Unit	Rate (¥) [including tax]
Peak Shift Plan (Peak-Controlled-Season-and-Time-Specific Lighting)	Demand charge	For 6 kVA or less	per contract	1,260.00
		For 7 kVA - 10 kVA	"	2,100.00
		For 11 kVA and over	"	¥2,100.00 + ¥273.00 × (Contract capacity - 10kVA)
	Energy charge	Peak hours	1kWh	53.16
		Day hours	"	28.18
		Night hours	"	11.82

* For the "Peak Shift Plan"(Peak-Controlled-Season-and-Time-Specific Lighting), "peak hours" refers to the time period from 1:00 p.m. to 4:00 p.m. every day between July 1 and September 30 each year. "Day hours" refers to the time period from 7:00 a.m. to 11:00 p.m. every day excluding "peak hours." "Night hours" refers to the time period from 11:00 p.m. to 7:00 a.m. of the next day.

Contract category		Unit	Rate (¥) [including tax]	
Omatome Plan (High-Load Low-Voltage Service)	Demand charge	1kW	1,260.00	
	Energy charge	1kWh	Summer 17.90	Other seasons 16.28

* For the "Omatome Plan"(High-Load Low-Voltage Service), "summer" refers to the period from July 1 through September 30 each year and "other seasons" refers to the period from October 1 each year through June 30 next year.

Contract category			Unit	Rate (¥) [including tax]	
Denka-Jozu (Season-and-Time-Specific Lighting)	Demand charge	For 6 kVA or less	per contract	1,260.00	
		For 7 kVA - 10 kVA	"	2,100.00	
		For 11 kVA and over	"	¥2,100.00 + ¥273.00 × (Contract capacity - 10kVA)	
	Energy charge	Day hours	For summer	1kWh	37.56
			For other seasons	"	30.77
		Morning and evening hours		"	25.20
		Night hours		"	11.82
	Discount	per 1 kVA for total capacity of 5-hour-auto-shutoff appliances			Discount of 241.50 yen
		per 1 kVA for total capacity where auto-shutoff nighttime thermal storage type appliances are used			Discount of 147.00 yen
		For all-electric homes			A 5% discount from the covered amount
	Minimum monthly charge			per contract	314.75

* For the "Denka-Jozu"(Season-and-Time-Specific Lighting), "summer" refers to the period from July 1 through September 30 each year and "other seasons" refers to the period from October 1 each year through June 30 next year. In this service option, "day hours" refers to the time period from 10:00 a.m. to 5:00 p.m. every day while "morning and evening hours" refers to the time period from 7:00 a.m. to 10:00 a.m. and 5:00 p.m. to 11:00 p.m. every day. "Night hours" refers to the time period from 11:00 p.m. to 7:00 a.m. of the next day.

* "Day hours" means "peak hours" and "morning and evening hours" means "off-peak hours" in the optional rules for supply of electricity.

* For the discount for all-electric homes, the "covered amount" refers to the electricity charge (except the fuel cost adjustment amount) except for the "day hours" in the "summer."

* The discount for all-electric homes is subject to a ceiling limit of 2,100.00 yen (including tax) a month.

* From March 31, 2013, we will no longer accept applications for the 5-hour auto-shutoff appliance discount.

As for the all-electric homes discount and appliance requirements of the "Denka-Jozu", consideration will be given so that broader peak shifts will be promoted along with the overall menu lineup amidst the careful establishment of a new rate menu in light of increasing smart meter installations.

Contract category			Unit	Rate (¥) [including tax]
Night-Only Service	Night-Only Service A		per contract	1,406.07
	Night-Only Service B	Demand charge	1kW	315.00
		Energy charge	1kWh	11.82
		In cases when "auto-shutoff nighttime thermal storage type appliances" are used		
	2nd Night-Only Service	Demand charge	1kW	210.00
		Energy charge	1kWh	10.88
Snow Melting Power Service	Demand charge	Up to first 3 months of the contracted period	1kW	2,005.50
		After 3 months	"	477.75
	Energy charge		1kWh	14.79

* From March 31, 2013, we will no longer accept applications for the "2nd Night-Only Service."

Contract category			Unit	Rate (¥) [including tax]	
Low-Voltage power per season and time-of-day for agricultural use	Demand charge	For 5 kW or less	per contract	5,355.00	
		Over 5kW	"	¥ 5,355.00 + ¥ 1,071.00 × (contract capacity-5kW)	
	Energy charge	Day hours	For summer	1kWh	19.41
			For other seasons	"	17.65
		Night hours		"	12.06

* For Low-Voltage power per Season and Time of Day for Agricultural Use, "summer" refers to the period from July 1 through September 30 each year and "other seasons" refers to the period from October 1 each year through June 30 next year. In this service option, "day hours" refers to the time period from 8:00 a.m. to 10:00 p.m. every day and "night hours" refers to the time period from 10:00 p.m. to 8:00 a.m. of the next day.

○ Electricity Supply and Demand Contract (High-Voltage)

Contract Category		Unit	Time/Season	Rate (Yen) [Inc. tax]			
Electric Power by Season and Time-of-Day for Commercial Use	Demand charge	1kW	-	1,638.00			
	Energy charge	1kWh	Peak	19.50			
			Daytime	Summer	18.82		
				Other seasons	17.46		
Night hours	12.10						
High-Voltage Power by Season and Time-of-Day	Demand charge	Contracted power 500kW or more	1kW	-	1,732.50		
		Contracted power less than 500kW	"	-	1,233.75		
	Energy charge	Contracted power 500kW or more	1kWh	Peak	18.24		
				Daytime	Summer	17.61	
					Other seasons	16.20	
				Night hours	12.10		
	Contracted power less than 500kW	"	Daytime	Peak	20.13		
				Summer	19.45		
				Other seasons	18.09		
				Night hours	12.10		
Electric Power for Commercial Use	Demand charge	1kW	-	1,638.00			
	Energy charge	1kWh	Summer	16.65			
			Other seasons	15.55			
High-Voltage Power	Demand charge	Contracted power 500kW or more	1kW	-	1,732.50		
		Contracted power less than 500kW	"	-	1,233.75		
	Energy charge	Contracted power 500kW or more	1kWh	Summer	15.34		
				Other seasons	14.37		
				Contracted power less than 500kW	"	Summer	16.49
						Other seasons	15.41

○ Electricity Supply and Demand Contract (Extra High-Voltage)

Contract Category		Unit	Time/Season	Rate (Yen) [Inc. tax]		
Special High-Voltage Electric Power by Season and Time-of-Day, A	Demand charge	20kV supply	1kW	-	1,585.50	
		60kV supply	"	-	1,533.00	
	Energy charge	20kV supply	1kWh	Peak		16.82
				Daytime	Summer	16.42
					Other seasons	15.14
		Night hours		11.88		
		60kV supply	"	Peak		16.61
				Daytime	Summer	16.03
	Other seasons				14.93	
	Night hours		11.67			
Special High-Voltage Electric Power by Season and Time-of-Day, B	Demand charge	20kV supply	1kW	-	1,585.50	
		60kV supply	"	-	1,533.00	
		140kV supply	"	-	1,480.50	
	Energy charge	20kV supply	1kWh	Peak		16.82
				Daytime	Summer	16.24
					Other seasons	15.14
		Night hours		11.88		
		60kV supply	"	Peak		16.61
				Daytime	Summer	16.03
	Other seasons				14.93	
	Night hours		11.67			
	140kV supply	"	Peak		16.40	
			Daytime	Summer	15.82	
				Other seasons	14.67	
Night hours			11.52			
Special High-Voltage Power, A	Demand charge	20kV supply	1kW	-	1,585.50	
		60kV supply	"	-	1,533.00	
	Energy charge	20kV supply	1kWh	Summer		15.10
				Other seasons		14.14
		60kV supply	"	Summer		14.86
Other seasons				13.93		
Special High-Voltage Power, B	Demand charge	20kV supply	1kW	-	1,585.50	
		60kV supply	"	-	1,533.00	
		140kV supply	"	-	1,480.50	
	Energy charge	20kV supply	1kWh	Summer		14.56
				Other seasons		13.66
		60kV supply	"	Summer		14.33
				Other seasons		13.45
140kV supply	"	Summer		14.10		
		Other seasons		13.24		

(4) Formulas for Calculating Electricity Rates (Monthly Bills) under Major Contract Categories

Contract categories			
Fixed Rate Lighting Service		¥52.50 (Customer charge) + Lamp charge + Small appliance charge ± Fuel cost adjustment + Renewable energy surcharge + Solar surcharge	
Meter-Rate Lighting Service A	For energy consumption up to 8 kWh	¥224.45 (Minimum charge) ± Fuel cost adjustment + Renewable energy surcharge + Solar surcharge	
	For energy consumption of 9 kWh and over	{¥224.45 + ¥18.89 × (Energy consumption - 8kWh)} ± Fuel cost adjustment + Renewable energy surcharge + Solar surcharge	
Meter-Rate Lighting Services B and C	Demand charge		
	· Meter-Rate Lighting Service B ... Demand charge as classified by contract current (10A - 60A)		
	· Meter-Rate Lighting Service C ... ¥273.00 × Contract capacity		
	Energy charge	For energy consumption up to 120 kWh	¥18.89 × Energy consumption ± Fuel cost adjustment
		For energy consumption over 120 kWh up to 300 kWh	¥18.89 × 120kWh + ¥25.19 × (Energy consumption - 120kWh) ± Fuel cost adjustment
For energy consumption over 300 kWh		¥18.89 × 120kWh + ¥25.19 × 180kWh + ¥29.10 × (Energy consumption - 300kWh) ± Fuel cost adjustment	
Charge		Demand charge + Energy charge + Renewable energy surcharge + Solar surcharge	
Otokuna-Night 8	Demand charge	For 6 kVA or less	¥1,260.00
		For 7 kVA - 10 kVA	¥2,100.00
		For 11 kVA and over	¥2,100.00 + ¥273.00 × (Contract capacity - 10kVA)
	Energy charge	For daytime energy consumption up to 90 kWh	¥23.15 × Daytime energy consumption + ¥11.82 × Nighttime energy consumption ± Fuel cost adjustment
		For daytime energy consumption over 90 kWh up to 230 kWh	¥23.15 × 90kWh + ¥30.87 × (Daytime energy consumption - 90kWh) + ¥11.82 × Nighttime energy consumption ± Fuel cost adjustment
		For daytime energy consumption over 230 kWh	¥23.15 × 90 kWh + ¥30.87 × 140kWh + ¥35.66 × (Daytime energy consumption - 230kWh) + ¥11.82 × Nighttime energy consumption ± Fuel cost adjustment
	Discount	When 5-hour-auto-shutoff appliances are used	¥241.50 × Total capacity of 5-hour-auto-shutoff appliances (kVA)
		When auto-shutoff nighttime thermal storage type appliances are used	¥147.00 × Total capacity of auto-shutoff nighttime thermal storage type appliances (kVA)
	Charge		Demand charge + Energy charge - Discount + Renewable energy surcharge + Solar surcharge
	Otokuna-Night 10	Demand charge	For 6 kVA or less
For 7 kVA - 10 kVA			¥2,100.00
For 11 kVA and over			¥2,100.00 + ¥273.00 × (Contract capacity - 10kVA)
Energy charge		For daytime energy consumption up to 80 kWh	¥25.20 × Daytime energy consumption + ¥12.06 × Nighttime energy consumption ± Fuel cost adjustment
		For daytime energy consumption over 80 kWh up to 200 kWh	¥25.20 × 80kWh + ¥33.60 × (Daytime energy consumption - 80kWh) + ¥12.06 × Nighttime energy consumption ± Fuel cost adjustment
		For daytime energy consumption over 200 kWh	¥25.20 × 80 kWh + ¥33.60 × 120kWh + ¥38.81 × (Daytime energy consumption - 200kWh) + ¥12.06 × Nighttime energy consumption ± Fuel cost adjustment
Discount		When 8-hour-auto-shutoff appliances are used	¥42.00 × Total capacity of 8-hour-auto-shutoff appliances (kVA)
		When 5-hour-auto-shutoff appliances are used	¥283.50 × Total capacity of 5-hour-auto-shutoff appliances (kVA)
		When auto-shutoff nighttime thermal storage type appliances are used	¥189.00 × Total capacity of auto-shutoff nighttime thermal storage type appliances (kVA)
Charge		Demand charge + Energy charge - Discount + Renewable energy surcharge + Solar surcharge	

Contract categories				
Peak Shift Plan	Demand charge	For 6 kVA or less	¥1,260.00	
		For 7 kVA - 10 kVA	¥2,100.00	
		For 11 kVA and over	¥2,100.00 + ¥273.00 × (Contract capacity - 10kVA)	
	Energy charge	For summer	¥53.16 × Peakttime energy consumption + ¥28.18 × Daytime energy consumption + ¥11.82 × Nighttime energy consumption ± Fuel cost adjustment	
		For other seasons	¥28.18 × Daytime energy consumption + ¥11.82 × Nighttime energy consumption ± Fuel cost adjustment	
Charge			Demand charge + Energy charge + Renewable energy surcharge + Solar surcharge	
Denka-Jozu	Demand charge	For 6 kVA or less	¥1,260.00	
		For 7 kVA - 10 kVA	¥2,100.00	
		For 11 kVA and over	¥2,100.00 + ¥273.00 × (Contract capacity - 10kVA)	
	Energy charge	For summer	¥37.56 × Daytime energy consumption + ¥25.20 × Morning and evening hour energy consumption + ¥11.82 × Nighttime energy consumption ± Fuel cost adjustment	
		For other seasons	¥30.77 × Daytime energy consumption + ¥25.20 × Morning and evening hour energy consumption + ¥11.82 × Nighttime energy consumption ± Fuel cost adjustment	
	Discount	When 5-hour-auto-shutoff appliances are used	¥241.50 × Total capacity of 5-hour-auto-shutoff appliances (kVA)	
		When auto-shutoff nighttime thermal storage type appliances are used	¥147.00 × Total capacity of auto-shutoff nighttime thermal storage type appliances (kVA)	
	Discount for all-electric homes	When the discount for all-electric homes applies	For summer	(¥25.20 × Morning and evening hour energy consumption + ¥11.82 × Nighttime energy consumption) × 5%
			For other seasons	(¥30.77 × Daytime energy consumption + ¥25.20 × Morning and evening hour energy consumption + ¥11.82 × Nighttime energy consumption) × 5%
	Charge			Demand charge + Energy charge - Discount - Discount for all-electric homes + Renewable energy surcharge + Solar surcharge
Night-Only Service B and 2nd Night-Only Service	Demand charge		Rate (including tax) × Contract demand	
	Energy charge		Rate (including tax) × Energy consumption ± Fuel cost adjustment	
	Discount for auto-shutoff nighttime thermal storage type appliances (only Night-Only Service B)		(Demand charge + Rate (including tax) × Energy consumption) × 13%	
	Charge		Demand charge + Energy charge - Discount (Only Night-Only Service B) + Renewable energy surcharge + Solar surcharge	
Low-Voltage Power Service, Omatome Plan	Demand charge		Rate (including tax) × Contract demand × $\frac{185 - \text{Power factor}}{100}$	
	Energy charge		Rate (including tax) for summer or other seasons × Energy consumption ± Fuel cost adjustment	
	Charge		Demand charge + Energy charge + Renewable energy surcharge + Solar surcharge	
Low-Voltage Power per season and time-of-day for agricultural use	Demand charge	For 5 kW or less	¥5,355.00 × $\frac{185 - \text{Power factor}}{100}$	
		Over 5 kW	{¥5,355.00 + ¥1,071.00 × (Contract capacity - 5kW)} × $\frac{185 - \text{Power factor}}{100}$	
	Energy charge	For summer	¥19.41 × Daytime energy consumption + ¥12.06 × Nighttime energy consumption ± Fuel cost adjustment	
		For other seasons	¥17.65 × Daytime energy consumption + ¥12.06 × Nighttime energy consumption ± Fuel cost adjustment	
	Charge			Demand charge + Energy charge + Renewable energy surcharge + Solar surcharge

* If there is no electricity usage whatsoever, the demand charge will be halved. (This does not apply to Fixed Rate Lighting Service or Meter-Rate Lighting Service A)

* The electricity bill of the customers eligible to receive minimum monthly rates is the sum of the minimum monthly electricity charge, the Renewable Energy Power Promotion Surcharge (Renewable energy surcharge) and the Photovoltaic Power Promotion Surcharge (Solar surcharge).

* The due date of payments is the 30th day after the meter reading day.

* As for the Fuel Cost Adjustment, please refer to P106.

* As for the Renewable Energy Power Promotion Surcharge (Renewable Energy Surcharge) and the Photovoltaic Power Promotion Surcharge (Solar Surcharge), please refer to P108 - 110.

(5) Fuel Cost Adjustment System

● Standard Unit Price under Fuel Cost Adjustment System

		Unit	Standard Unit Price (Yen) [Inc. tax]		
Meter-Rate System	Low-Voltage Supply (Lighting, Low-Voltage Power Service, etc.)	1kWh	0.222		
	High-Voltage Supply	"	0.214		
	Extra High-Voltage Supply	"	0.211		
Fixed Rate System	Fixed Rate Lighting Service / Public Street Lighting Service, A	Lighting	Up to 10W	Per lamp	0.861
			Over 10W to 20W	"	1.721
			Over 20W to 40W	"	3.442
			Over 40W to 60W	"	5.163
			Over 60W to 100W	"	8.605
			For every 100W over 1st 100W	"	8.605
	Small Appliances	Up to 50VA	Per appliance	2.570	
		Over 50VA to 100VA	"	5.141	
		For every 100VA over 1st 100VA	"	5.141	
	Temporary Lighting Service, A	Lighting	Up to 50VA	Per contract, per day	0.069
			Over 50VA to 100VA	"	0.139
			For every 100VA, over 1st 100VA up to 500VA	"	0.139
			Over 500VA to 1kVA	"	1.387
			For every 1kVA, over 1st 1kVA up to 3kVA	"	1.387
			Temporary Power Service	Per kW, per day	1.457
Late-Night Electric Power, A	Per contract	22.155			

● Calculating Fuel Cost Adjusted Unit Price

- When the "average fuel price" fluctuates by 1,000 yen/kℓ, the fuel cost adjusted unit price is treated as the "standard unit price."
- The average fuel price is the price/kℓ in crude oil equivalents, calculated based on the 3-month (actual recorded) prices derived from Foreign Trade Statistics for crude oil, LNG and coal published by Ministry of Finance Japan. The average fuel price is calculated as below.

Average fuel price = $A \times \alpha + B \times \beta + C \times \gamma$ (values less than 100 yen rounded off)

A: Average crude oil price/kℓ in each quarter	α : 0.1970
B: Average LNG price/ton in each quarter	β : 0.4435
C: Average coal price/ton in each quarter	γ : 0.2512

- The fuel cost adjusted unit price is calculated based on the average fuel price and the standard unit price.
 - If the average fuel price is below 44,200 yen
Unit price = $(44,200 \text{ yen} - \text{Average fuel price}) \times \frac{\text{Standard unit price}}{1,000}$
 - If the average fuel price is above 44,200 yen
Unit price = $(\text{Average fuel price} - 44,200 \text{ yen}) \times \frac{\text{Standard unit price}}{1,000}$

Note: For low-voltage power contract customers, if the average fuel price is above 66,300 yen, this 66,300 yen shall be the maximum price. In this case, for the portion of the average fuel price beyond 66,300 yen, no adjustment is to be applied.

● Calculating Electricity Rates (monthly) under Fuel Cost Adjustment System

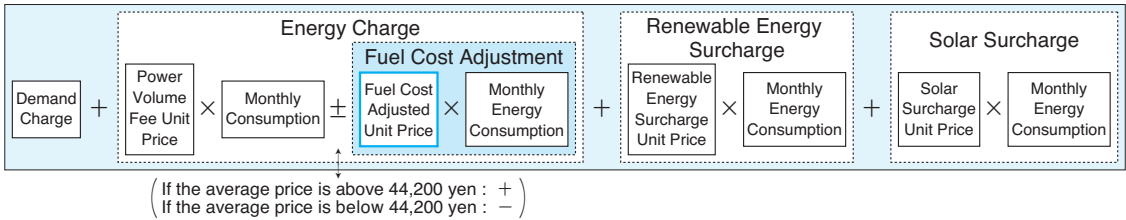

- *1 Every month's "fuel cost adjusted unit price" is posted in advance at TEPCO's branch offices, service centers, the official homepage etc. in addition to notifications sent out with each customers' monthly usage statements.
- *2 Please refer to P108 - 110 for the Renewable Energy Power Promotion Surcharge (Renewable Energy Surcharge) and the Photovoltaic Power Promotion Surcharge (Solar Surcharge).

● Fuel Cost Calculation Period and its Application to the Electricity Rates

The fuel cost adjusted unit price for every month shall be calculated based on average fuel prices recorded over a 3-month period.

For example, the fuel cost adjusted unit price calculated based on (actual recorded) average fuel prices from January to March, shall be applied to June electricity prices.

[Conceptual Diagram]

Jan.	Feb.	Mar.	Apr.	May	Jun.	Jul.	Aug.	Sep.
Trade Statistics Prices from January to March			→			Electricity Rates for June		
	Trade Statistics Prices from February to April		→			Electricity Rates for July		
		Trade Statistics Prices from March to May		→			Electricity Rates for August	

(6) Renewable Energy Power Promotion Surcharge (Renewable Energy Surcharge) based on the Feed-in Tariff Scheme for Renewable Energy and the Photovoltaic Power Promotion Surcharge (Solar Surcharge) based on the Surplus Electricity Buyback Program for Photovoltaic Power Generation

Based on the "Feed-in Tariff Scheme for Renewable Energy," the purchase costs of power generated by renewable energy will be added to the electricity bill as a "Renewable Energy Surcharge" for customers. The "Surplus Electricity Buyback Program for Photovoltaic Power Generation" was replaced by the "Feed-in Tariff Scheme for Renewable Energy" in July 2012. However, since the timing of charging the purchase cost is different for these two systems, we must request that our customers bear both the "Renewable Energy Surcharge" and "Solar Surcharge" during the transitional period.

Note: Please refer to page P116 - 117 for purchase conditions.

● Calculation of the Renewable Energy Surcharge unit price and the Solar Surcharge unit price

The "Renewable Energy Surcharge unit price" (per kWh) for the said fiscal year (from April to March of the next year) is determined by the government based on the estimated subsidy amount to be given to each electric utility according to the purchase costs and the expected amount of each utility's power supply in the said fiscal year.

The "Solar Surcharge unit price" is calculated based on the actual costs incurred in the surplus electricity buyback from January to December of the previous year.

● The outline of the FY2012 "Renewable Energy Surcharge unit price" and the "Solar Surcharge unit price" calculation

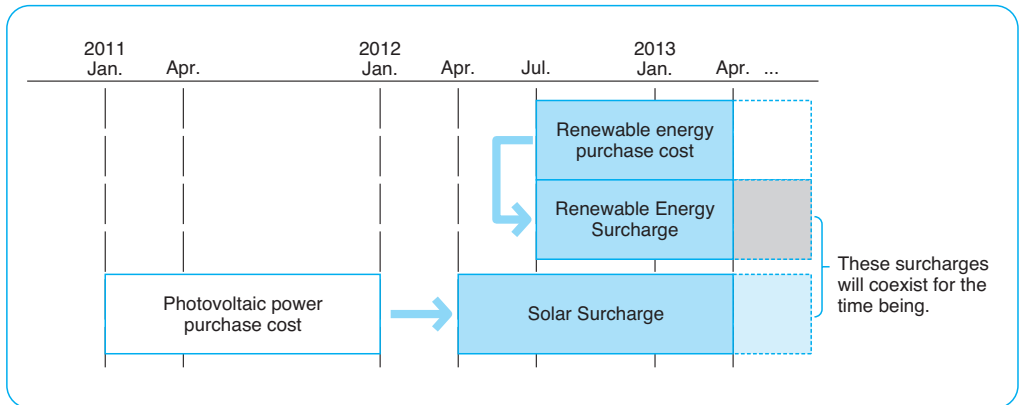

● Exemptions from the Renewable Energy Surcharge and the Solar Surcharge

Those involved in energy-intensive businesses*¹ are eligible to be exempt from the "Renewable Energy Surcharge" and those afflicted by the Great East Japan Earthquake*² are eligible to be exempt from the "Renewable Energy Surcharge" and the "Solar Surcharge."

- *1 The basic unit of electricity consumption (consumption amount per sales intake) for manufacturers must exceed 8 times the average. Non-manufacturing business entities fall under the conditions set down by the national government. For them, it is stipulated that the basic unit must exceed the non-manufacturing business entities' multiple as established by the government (Government approval and notification to TEPCO required).
- *2 Those certified by the government as being afflicted by house or other facility/equipment damage due to the Great East Japan Earthquake or those who used electric power in the designated evacuation zone due to the nuclear accident that followed the Great East Japan Earthquake and evacuated to our service area (Notification to TEPCO required).

● How the Renewable Energy Surcharge and the Solar Surcharge are charged (Metered supply)

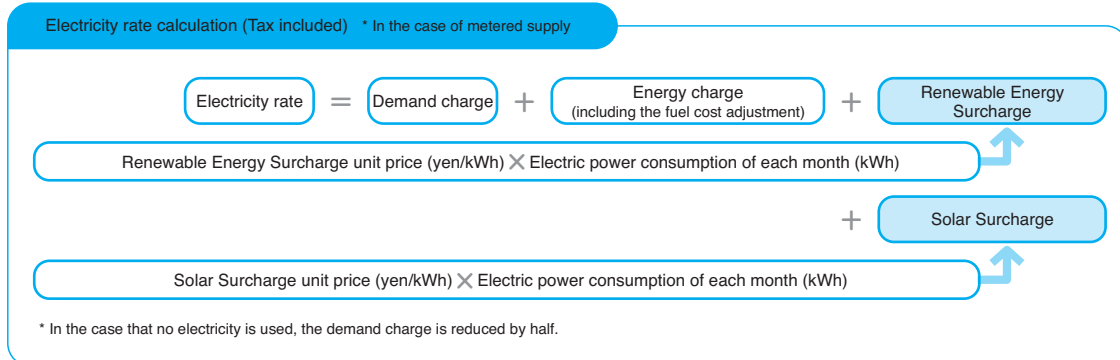

* Please refer to such documentation as the monthly electricity usage statement and the monthly electricity rate bill (itemized electricity rate statement) for the surcharge amounts included in the monthly electricity bill.

● The Renewable Energy Surcharge Unit Price and the Solar Surcharge Unit Price (FY2012)

		Unit	Renewable Energy Surcharge Unit Price (Inc. tax)	Solar Surcharge Unit Price (Inc. tax)		
Meter-Rate System	Low-Voltage Supply (Lighting, Low-Voltage Power Service, etc.)	1kWh	¥ 0.22	¥ 0.06		
	High-Voltage Supply	"	0.22	0.06		
	Extra High-Voltage Supply	"	0.22	0.06		
Fixed Rate System	Fixed Rate Lighting Service / Public Street Lighting Service, A	Lighting	Up to 10W	Per lamp	0.85	0.24
			Over 10W to 20W	"	1.71	0.49
			Over 20W to 40W	"	3.42	0.98
			Over 40W to 60W	"	5.13	1.47
			Over 60W to 100W	"	8.54	2.45
			For every 100W over 1st 100W	"	8.54	2.45
	Small Appliances	Up to 50VA	Per appliance	2.55	0.74	
		Over 50VA to 100VA	"	5.10	1.46	
		For every 100VA over 1st 100VA	"	5.10	1.46	
	Temporary Lighting Service, A	Up to 50VA	Per contract, per day	0.07	0.02	
		Over 50VA to 100VA	"	0.14	0.04	
		For every 100VA, over 1st 100VA up to 500VA	"	0.14	0.04	
		Over 500VA to 1kVA	"	1.38	0.40	
		For every 1kVA, over 1st 1kVA up to 3kVA	"	1.38	0.40	
	Temporary Power Service	Per kW, per day	1.45	0.41		
Late-Night Electric Power, A	Per contract	22.00	6.30			

Note: As for the Renewable Energy Surcharge unit price for FY2012, application is started from the electricity charge for August 2012.

(7) Ratios of Electricity Bills to Household Expenses and Production Amount

a. Ratio of Electricity Bills to Household Expenses (all households nationwide)

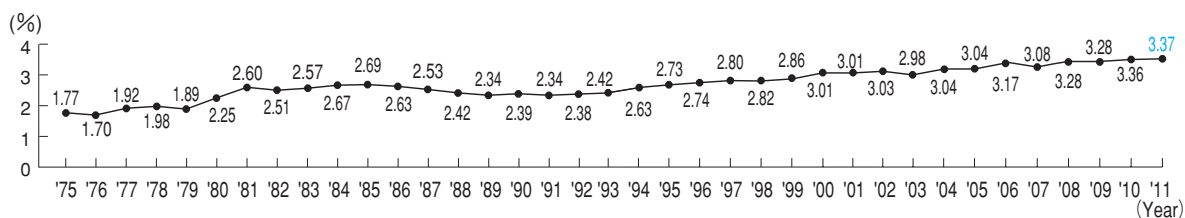

Source: "Annual Report on Family Income and Expenditure Survey," Statistics Bureau, Ministry of Internal Affairs and Communications.

b. Ratio of Electricity Bills to Production Amount (total for manufacturing industry sector)

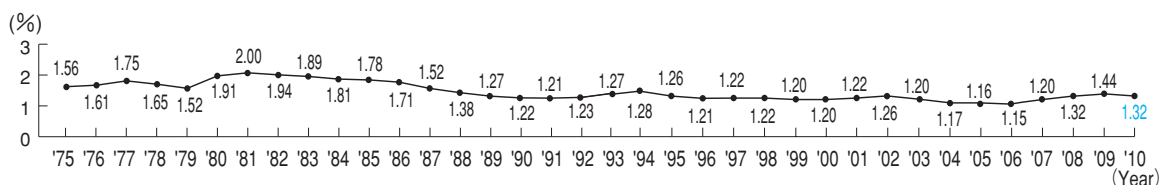

Source: "Census of Manufactures," Research and Statistics Department, Economic and Industrial Policy Bureau, Ministry of Economy, Trade and Industry.

c. Ratio of Electricity Bills to Production Amount (by industry)

Type	Ratio of Purchased Power Consumption to Production Amount (%)															
	1995	1996	1997	1998	1999	2000	2001	2002	2003	2004	2005	2006	2007	2008	2009	2010
Foodstuffs	1.13	1.12	1.15	1.15	1.13	1.16	1.20	1.20	1.18	1.18	1.21	1.21	1.25	1.26	1.28	1.25
Textiles *1	2.96	2.89	2.92	2.92	2.88	2.91	2.98	3.01	2.88	2.82	2.91	2.82	2.83	2.31	2.46	2.25
Paper and Pulp	1.84	1.78	1.87	1.86	1.80	1.82	1.88	1.99	1.88	1.84	1.88	2.01	2.05	2.10	2.05	2.00
Chemicals	1.54	1.51	1.55	1.53	1.45	1.46	1.45	1.44	1.40	1.39	1.44	1.53	1.54	1.68	1.67	1.61
Oil and Coal Products	0.68	0.64	0.55	0.52	0.44	0.38	0.36	0.35	0.35	0.32	0.29	0.26	0.34	0.37	0.39	0.28
Clay and Stone	3.16	3.03	3.04	3.04	2.95	2.90	2.99	3.20	3.14	3.05	2.92	2.96	3.02	3.23	3.71	3.29
Iron and Steel	3.75	3.60	3.66	3.59	3.62	3.74	3.82	3.92	3.54	3.20	2.87	2.97	2.92	3.05	3.51	3.34
Nonferrous Metals	2.60	2.45	2.46	2.50	2.61	2.55	2.58	2.54	2.58	2.34	2.19	1.75	1.66	1.98	2.58	1.97
(Zinc)	(14.32)	(11.52)	(10.83)	(11.98)	(11.91)	(12.42)	(14.84)	(16.48)	(14.38)	(17.57)	(12.97)	(9.06)	(10.85)	(13.79)	(16.35)	(13.82)
General Machinery *2	0.77	0.75	0.76	0.77	0.82	0.81	0.83	0.88	0.83	0.78	0.76	0.72	0.73	0.79	0.94	0.84
Electrical Machinery	0.89	0.87	0.86	0.91	0.92	0.89	0.98	0.83	0.76	0.75	0.76	0.76	0.72	0.69	0.80	0.71
Transport Machinery	0.80	0.78	0.78	0.78	0.75	0.77	0.73	0.67	0.64	0.63	0.60	0.56	0.63	0.69	0.78	0.70
Total for Manufacturing Industry Sector	1.26	1.21	1.22	1.22	1.20	1.20	1.22	1.26	1.20	1.17	1.16	1.15	1.20	1.32	1.44	1.32

*1 Since FY2008, clothes and other textile products are included.

*2 Since FY2008, total amount for the "general-purpose machinery and apparatuses manufacturing industry," "production machinery and apparatuses manufacturing industry" and "business-use machinery and apparatuses manufacturing industry" are combined. (The amount now includes part of the amount for the former "precision machinery and apparatuses manufacturing industry" category because of the change of the classification).

Source: "Census of Manufactures," Research and Statistics Department, Economic and Industrial Policy Bureau, Ministry of Economy, Trade and Industry.

<Reference> Comparison of Rate Increases for Electric Power and Other Public Services
(in Tokyo Metropolitan 23 wards)

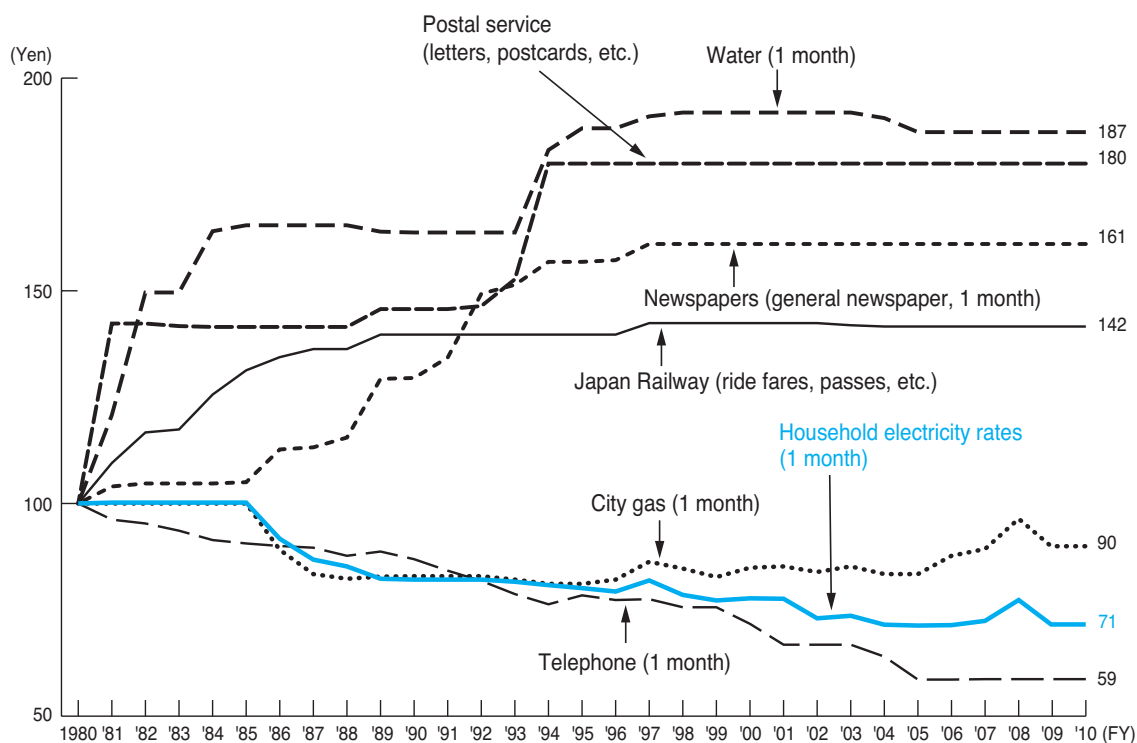

Source: Document of Statistics Bureau, Ministry of Internal Affairs and Communications

(8) Calculation Process of Electricity Rates

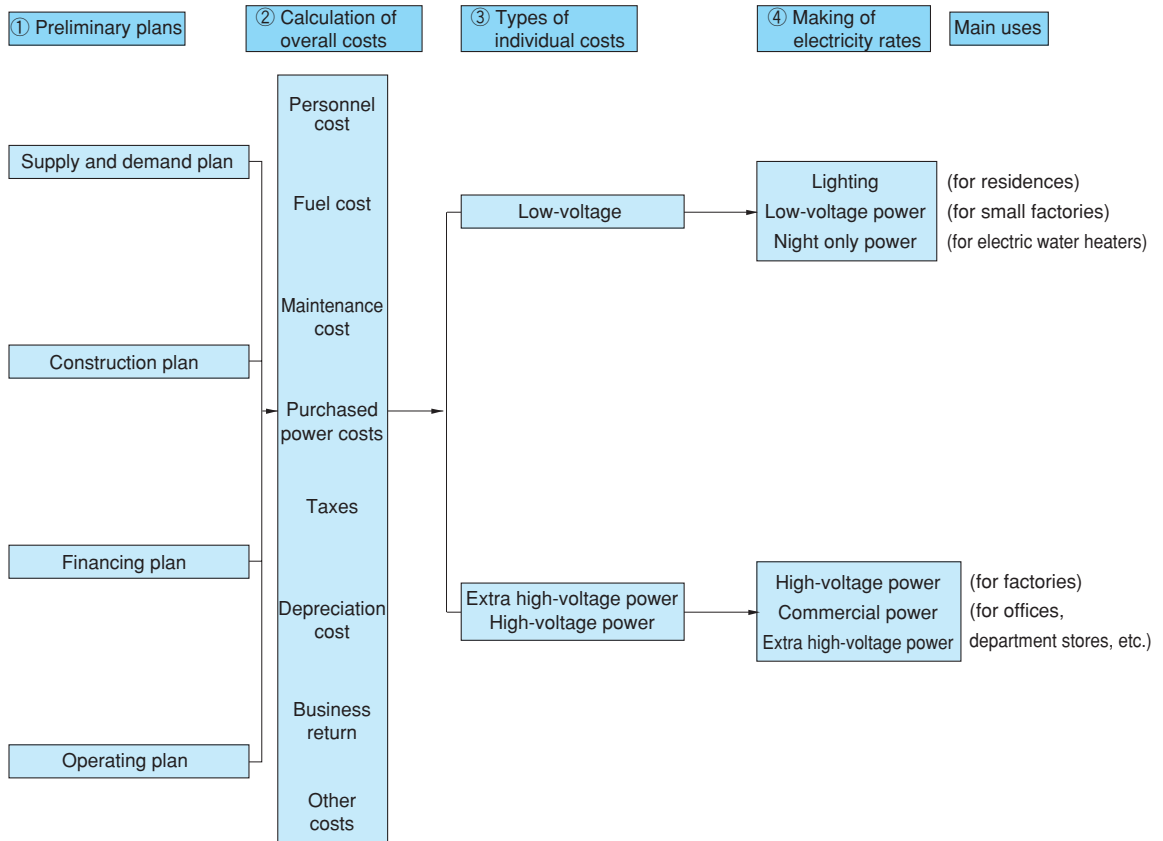

Note: Business return is equivalent to interest expense, dividend, and other like. It is the sum total of electric utility fixed assets, nuclear fuel assets, assets under construction, deferred assets, working capital, and designated investment as a rate base, multiplied by the rate of return.

2. Electricity Rate Systems

(1) Number of Customers Served and Contract Power by Use

(as of the end of March 2012)

Use		Item		Demand		
				Number of Customers	Contract Power (kW)	
Other than Specified-Scale Demand	Lighting Services	Fixed Rate		401,148		
		Meter-Rate	(A and B)	19,961,879		
			(C)	1,239,816	15,409,468	
		Other Lighting Service Contracts	Temporary		62,427	
			Public Street Light		3,787,946	
			(Optional Contracts)		1,203,195	10,272,370
			Subtotal		5,053,568	
	Lighting Total		26,656,411			
	Power Services	Low-Voltage		(216)	(4,671)	
		Other Power Service Contracts	Temporary		1,674,512	12,698,857
			Agricultural		5,610	129,334
			Power for TEPCO's Construction Work		11,187	59,099
			Power for TEPCO's Business Operations		209	4,315
			(Optional Contracts)		63,729	55,508
			Subtotal		351,592	1,442,424
		Power Total		432,327	1,690,680	
	Total		2,106,839	14,389,537		
		28,763,250				

- Notes:
1. Figures given are based on electric service contracts.
 2. Figures given for total of Optional Contracts in Lighting Services are based on the total for "Time-Specific Lightning (8-Hour, 10-Hour Night Service)," "Season-and-Time-Specific Lightning" and "High-Load Low-Voltage Service."
 3. Figures in parentheses represent those for "Low-Voltage Power per Season and Time-of-Day for Agricultural Use."
 4. Figures given for total of Optional Contracts in Power Services are based on the total for "Night-Only Service," "2nd Night-Only Service," "Snow Melting Power Service," and "Low-Voltage Power per Season and Time-of-Day for Agricultural Use."
 5. Figures given are rounded off.
 6. The above figures exclude the number of customers of the specific-scale demand and are based on electric service contracts.

(2) Major Optional Tariffs for Low-Voltage Customers (Households, Stores, etc.)

Optional Contract Menu	Summary
Time-Specific Lightning "8-Hour Night Service" ("Otokuna-Night 8") Time-Specific Lightning "10-Hour Night Service" ("Otokuna-Night 10")	An option that offers discount rates at night with higher rates during the day. The higher the proportion of electricity consumed at night, the lower the electricity rates.
Season-and-Time-Specific Lightning ("Denka-Jozu")	Recommended for residential customers who use "Eco Cute", an electric water heater, and other kinds of overnight thermal storage equipment (over 1kVA), as well as an electric kitchen. A discount for customers with fully-electrified homes is also available.
Peak-Controlled-Season-and-Time-Specific Lighting ("Peak Shift Plan")	An optional electricity rate menu allowing for reduced electricity charges via curbing electricity during summer peak hours or shifting electricity usage to off-peak hours.
Electric Kitchen Home Contract * ("Smile Cooking Discount")	An option that offers discounted electricity charges for IH cooking heaters and other cooking equipment with the rated voltage of 200V.
High-Load Low-Voltage Service Contract ("Omatome Plan")	An option that offers discounted electricity charges through the efficient use of both lighting and power equipment throughout the year.
Low-Voltage Power per Season and Time-of-Day for Agricultural Use	Recommended for customers who use electrical air-conditioning (power equipment) for crop cultivation.
Low-Voltage Thermal Storage Adjustment Contract	An option that offers discounted electricity charge for sifting consumption from daytime to nighttime through the use of thermal storage operation such as thermal storage air conditioner.
Automatic Bank Transfer Discount	A discount is available to customers paying electricity bills regularly and without delay through account transfer.
Advance One-Time Payment Contract	A discount is available to customers paying electricity bills six months or one year in advance, in a single transaction.
Night-Only Service 2nd Night-Only Service *	Lower electricity rates are offered to customers who use electric water heaters and other facilities only during the night.
Snow Melting Power Service	Discount rates are available to customers who use electric power to melt snow for a limited period every year, and who can set a daily two-hour break during the period.

* From March 31, 2013, we will no longer accept applications for "Electric Kitchen Home Contract" and "2nd Night-Only Service."

(3) Feed-in Tariff Scheme for Renewable Energy (Effective from July 1, 2012)

The Feed-in Tariff Scheme for Renewable Energy requires electric power companies, etc. to purchase the power generated by renewable energy at a fixed price during a fixed period of time. The power purchase price costs will be added to the customers' electricity bill.

[* Please refer to page P108 - 110 for the amount incurred (Renewable Energy Power Promotion Surcharge)]

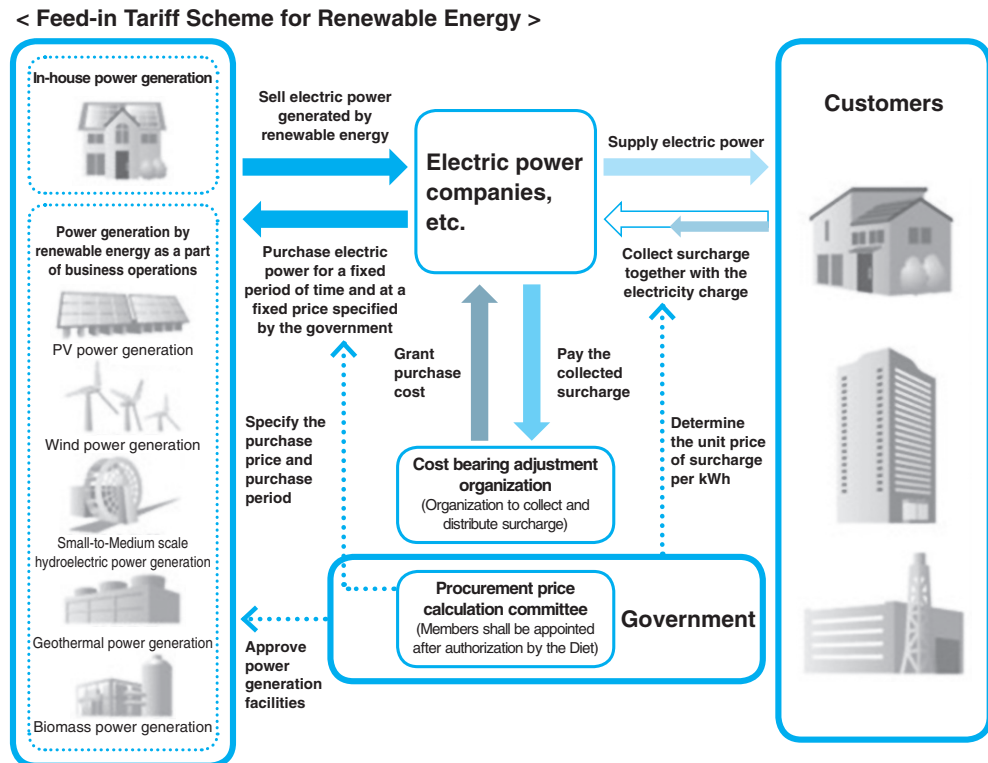

* Created based on information posted on the web page of the Agency for Natural Resources and Energy of the Ministry of Economy, Trade and Industry.

a. Electric Power to be Purchased

Electric power generated by renewable energy (Photovoltaic, wind, hydroelectricity, geothermal, biomass, etc.)

b. Purchase Price and Purchase Period

- The purchase price and period are determined based on such factors as the type of renewable energy and scale of power generation.
- Refer to the following chart for the FY2012 purchase price and purchase period.

The following purchase price and purchase period are applied to the renewable energy power generation facility applications (approved power facilities) newly received during the period of July 1, 2012 to March 31, 2013 in accordance with the Ministry of Economy, Trade and Industry Notification 139 (2012).

Categories of renewable energy power generation facilities, etc.			Purchase price (Yen/kWh, tax included)	Purchase period (Year)
Photovoltaic	Output: Less than 10kW	Single installation	42.00	10
		Installed along with in-house power generation facilities, etc. (In the case that the power generated by the power generation facilities affects the supply amount of the power generated by renewable energy)	34.00	10
	Output: 10kW or more		42.00	20
Wind	Output: Less than 20kW		57.75	20
	Output: 20kW or more		23.10	20
Hydroelectric	Output: Less than 200kW		35.70	20
	Output: 200kW or more, less than 1,000kW		30.45	20
	Output: 1,000kW or more, less than 30,000kW		25.20	20
Geothermal	Output: Less than 15,000kW		42.00	15
	Output: 15,000kW or more		27.30	15
Biomass	1. Equipment which transforms methane (obtained from fermented biomass) into electric power		40.95	20
	2. Equipment which transforms unused woody biomass generated from cut down standing trees and bamboos or timber from forest thinning (excluding imported wood) into electric power (Excluding 1 above and domestic waste power generation facilities)		33.60	20
	3. Equipment which transforms woody biomass or biomass generated from harvesting of agricultural produce (confined to biomass derived from the said agricultural produce) into electric power (Excluding 1, 2 (above), 4 (below) and domestic waste power generation facilities)		25.20	20
	4. Equipment which transforms construction material waste into electric power (Excluding 1 above and domestic waste power generation facilities)		13.65	20
	5. Domestic waste power generation facilities or biomass power generation facilities excluding 1 to 4 above		17.85	20

- Notes:
- As for the renewable energy power generation facilities (photovoltaic (with outputs of 10kW or more), wind, hydroelectric, geothermal or biomass), agreement must be made to pay for the incurred preparation costs in case applications are cancelled.
 - The certified photovoltaic power generation facilities with outputs of less than 10kW and owned by those operating multiple solar power generation facilities ("Solar roof rent") are deemed to be photovoltaic power generation facilities with outputs of 10kW or more.
 - The purchase price/period applied to the cases where multiple renewable energy power generation facilities coexist and the power supply amount of each facility cannot be identified.
Purchase price: The lowest purchase price of all the (categories of) power generation facilities owned.
Purchase period: The purchase period set accordingly to the purchase price above.

(4) Wheeling Service

As retail electric power has become deregulated, TEPCO offers its "wheeling service" to PPSs (Power Producer and Supplier) through our power transmission and distribution network.

- When PPSs supply electricity to their customers, TEPCO receives electricity from the PPSs and delivers electricity to customers and PPSs' facilities through TEPCO's power transmission and distribution network.
* Note: The wheeling service is for the service points where high voltage or greater power is supplied.
- When a PPS is unable to keep up with fluctuations in demand, TEPCO supplies backup power.

[Wheeling Service Concept]

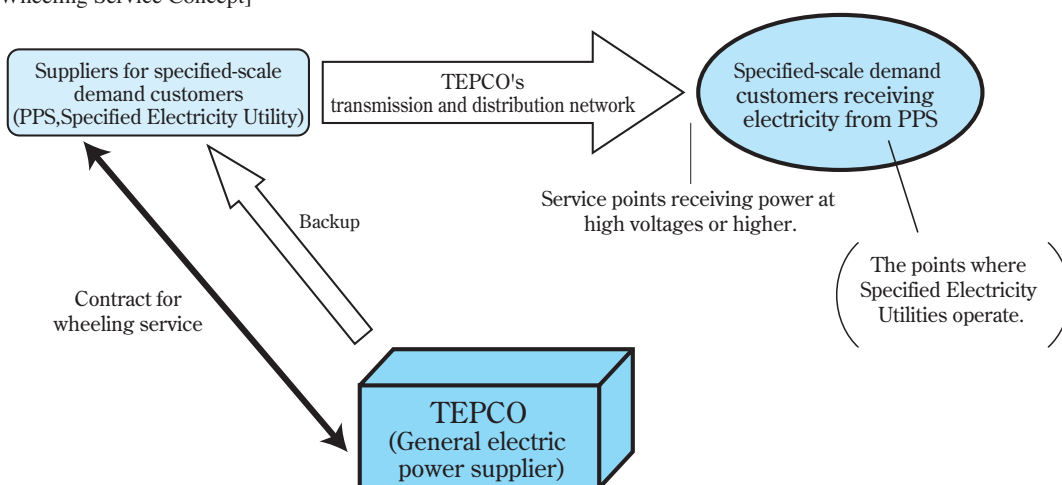

- Regarding wheeling service: TEPCO sets fair charges and network costs that are borne by the customer to whom TEPCO supplies electricity according to the calculation rules set under the Ordinance of the Ministry of Economy, Trade and Industry.

[Reference]

Rates for "Standard Electricity Transmission Service" (become effective on September 1, 2012)

When supplied at high-voltages: Demand charge 535.50yen/kW, Energy charge 2.26yen/kWh

When supplied at extra-high-voltages: Demand proportioned charge 351.75yen/kW, Energy charge 1.22yen/kWh

* Photovoltaic Power Promotion Surcharge is added to the rates above for electricity rates.

Application for wheeling service is accepted and related documents are arranged at the TEPCO Network Service Center at the address below.

Network Service Center

Tokyo Takarazuka Building 12F

1-1-3 Yurakucho, Chiyoda-ku, Tokyo 100-0006 Japan

Tel: 03-3509-1709

(as of the end of July 2012)

IX. Capital Investment and Financing

1. Changes in Capital Investment and Plans

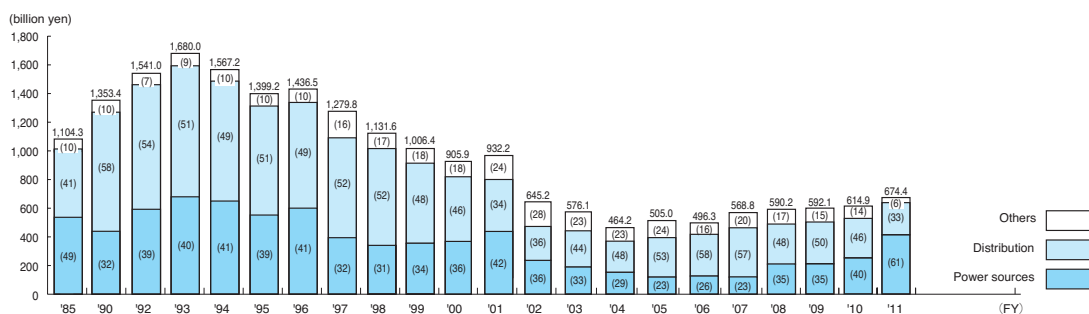

- Notes:
1. Figures in parentheses represent the percentage composition (%).
 2. "Distribution" includes transmission, transformation and distribution.
"Others" includes nuclear fuels and operation facilities.

2. Changes (Net Increase) in Plans for Raising Equipment Funds

(1) TEPCO

(Unit: billion yen)

FY		1985	1990	1995	1997	1998	1999	2000	2001	2002	2003	2004	2005	2006	2007	2008	2009	2010	2011	
Fund Requirements (construction funds)		1,104.3	1,353.4	1,399.2	1,279.8	1,131.6	1,006.4	905.9	932.2	645.2	576.1	464.2	505.0	496.3	568.8	590.2	592.1	614.9	674.4	
Financing	Internal Funds	949.3	973.0	1,092.6	1,317.6	1,154.1	1,305.2	1,233.1	1,371.9	1,103.3	963.1	1,141.3	784.9	944.0	274.2	323.3	957.5	-903.9	1301.0	
	Internal Reserve	883.1	972.1	1,047.3	1,264.9	1,252.1	1,661.9	1,314.8	1,385.4	1,184.5	943.0	1,120.7	730.2	955.4	445.0	512.4	627.6	349.9	51.1	
	Customer Contribution, etc.	66.2	0.9	45.2	52.7	-98.0	-356.6	-81.7	-13.4	-81.2	20.0	20.6	54.6	-11.3	-170.7	-189.1	329.8	-1,700.7	1,249.9	
	Capital Increase (amount of issue)	(-)	(13.2)	(6.0)	(-)	(-)	(-)	(-)	(-)	(-)	(-)	(-)	(-)	(-)	(-)	(-)	(-)	(-)	(449.0)	(-)
	Net Proceeds from Capital Increase	(-)	(-)	(-)	(-)	(-)	(-)	(-)	(-)	(-)	(-)	(-)	(-)	(-)	(-)	(-)	(-)	(-)	446.8	(-)
	External Funds	154.9	380.4	306.5	-37.8	-22.5	-298.7	-327.1	-439.6	-458.0	-387.0	-677.1	-279.8	-447.6	294.5	266.9	-365.4	1,518.9	-626.6	
	Bonds (amount of issue)	(311.0)	(600.0)	(600.0)	(856.3)	(799.7)	(595.8)	(700.0)	(763.5)	(800.0)	(534.2)	(250.0)	(250.0)	(329.1)	(750.0)	(670.0)	(240.3)	(235.0)	(-)	
Proceeds from Bond Issue	67.3	278.7	187.7	487.7	254.4	-296.8	-184.1	-101.9	87.2	70.7	125.4	-156.2	-400.0	55.6	72.5	-186.2	-195.7	-548.9		
Borrowings	87.6	101.6	118.8	-525.5	-277.0	-1.9	-143.0	-337.6	-545.3	-457.7	-802.5	-123.6	-47.5	238.8	194.4	-179.1	1,714.7	-77.7		
Total	1,104.3	1,353.4	1,399.2	1,279.8	1,131.6	1,006.4	905.9	932.2	645.2	576.1	464.2	505.0	496.3	568.8	590.2	592.1	614.9	674.4		

- Notes: 1. Figures for the actual results are expressed by dropping fractions smaller than 0.1 billion yen.
2. Incidental construction costs are excluded.

<Reference> Changes (net increase) in Plans for Raising Equipment Funds

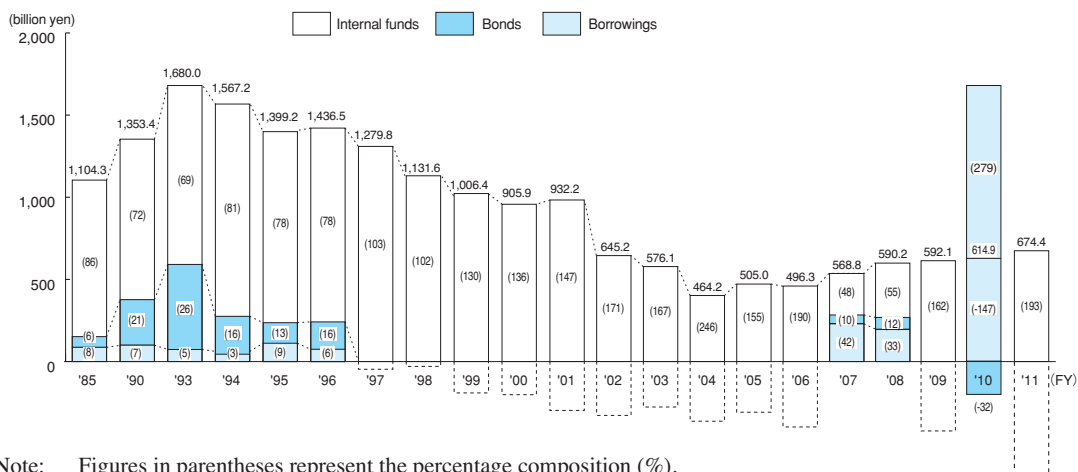

Note: Figures in parentheses represent the percentage composition (%).

(2) 10 Electric Power Companies

(Unit: billion yen)

FY		1985	1990	1995	1997	1998	1999	2000	2001	2002	2003	2004	2005	2006	2007	2008	2009	2010	2011
Fund Requirements (construction funds)		3,037.2	3,826.2	4,442.0	4,017.8	3,553.1	3,258.7	2,927.0	2,632.6	2,075.9	1,770.5	1,512.5	1,497.9	1,529.1	1,854.2	2,124.2	2,034.4	2,123.1	2,123.2
Financing	Internal Funds	2,606.9	2,682.9	3,472.9	4,077.3	3,480.5	3,812.2	3,761.8	3,733.5	3,473.0	3,419.5	3,551.8	2,001.1	2,452.0	1,710.5	1,355.1	3,009.6	548.2	863.0
	Internal Reserve	2,433.0	2,690.7	3,299.4	3,740.0	3,654.5	4,247.7	3,870.2	3,965.5	3,694.8	3,483.7	3,602.6	2,136.3	2,727.1	1,991.4	1,957.1	2,381.5	2,223.9	475.2
	Customer Contribution, etc.	143.7	-7.7	173.5	337.2	-174.0	-435.5	-108.4	-232.0	-221.7	-64.1	-50.8	-135.1	-275.0	-280.9	-802.0	628.1	-2,122.5	387.7
	Capital Increase (amount of issue)	(31.0)	(34.7)	(17.9)	(0)	(0)	(0.1)	(-)	(0)	(-)	(-)	(-)	(56.2)	(-)	(-)	(-)	(-)	(-)	(-)
	Net Proceeds from Capital Increase	30.0	-	-	-	-	-	-	-	-	-	-	-	-	-	-	-	446.8	-
	External Funds	439.0	1,143.2	969.1	-59.5	72.5	-553.5	-834.7	-1,100.8	-1,397.1	-1,648.9	-2,039.2	-503.2	-922.9	143.6	769.1	-975.2	1,574.8	1,260.2
	Bonds (amount of issue)	(866.2)	(1,865.6)	(1,735.4)	(2,360.6)	(2,369.7)	(1,808.8)	(1,745.0)	(1,769.5)	(1,667.5)	(1,130.2)	(740.0)	(925.0)	(1,054.5)	(1,666.0)	(1,800.0)	(690.3)	(775.0)	(-234.6)
Proceeds from Bond Issue	159.0	862.1	356.3	753.8	714.3	-262.4	-478.5	-601.9	-101.8	-483.5	-792.3	-54.1	-332.2	306.2	367.5	-183.1	-88.8	-1,291.9	
Borrowings	280.0	281.0	612.8	-813.3	-641.8	-291.1	356.1	-498.9	-1,295.2	-1,163.4	-1,246.9	-449.1	-590.7	-162.6	401.5	-792.0	1,663.6	2,552.1	
Total		3,037.2	3,826.2	4,442.0	4,017.8	3,553.1	3,258.7	2,927.0	2,632.6	2,075.9	1,770.5	1,512.5	1,497.9	1,529.1	1,854.2	2,124.2	2,034.4	2,123.1	2,123.2

- Notes:
1. Figures for FY2011 are those from "Statistics of Electric Power Industry."
 2. Figures are expressed by dropping fractions smaller than 0.1 billion yen.
 3. Incidental construction costs are excluded.
 4. Numbers are for a total of 9 power companies (except Okinawa Electric Power Company) before FY1985.

Source: "Handbook of Electric Power Industry"

<Reference> Changes (10 electric power companies) in Plans for Raising Equipment Funds

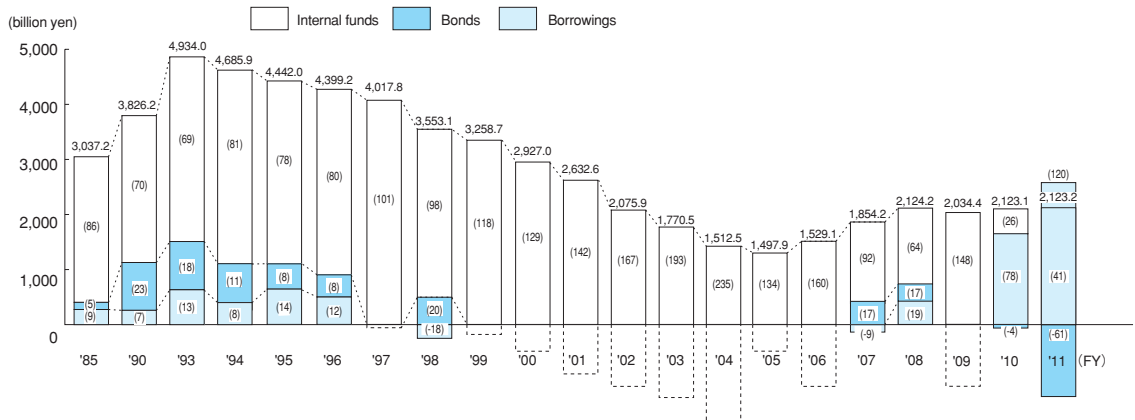

- Notes:
1. Figures in parentheses represent the percentage composition (%).
 2. Numbers are for a total of 9 power companies (except Okinawa Electric Power Company) before FY1985.

<Reference> Changes in Private Sector Capital Investment

(Unit: billion yen)

FY1980	39,680.7	FY2002	64,418.7
FY1985	54,556.0	FY2003	65,848.1
FY1990	92,096.7	FY2004	67,846.9
FY1995	72,221.8	FY2005	70,635.7
FY1996	74,507.9	FY2006	74,650.7
FY1997	78,190.0	FY2007	76,831.7
FY1998	70,948.6	FY2008	71,014.7
FY1999	69,827.9	FY2009	60,771.1
FY2000	72,076.4	FY2010	62,030.5
FY2001	67,686.7	FY2011	62,034.7

Source: "Annual Report on National Accounts," Economic and Social Research Institute, Cabinet Office.

<Reference> Comparison of Investment by Industry (FY2011)

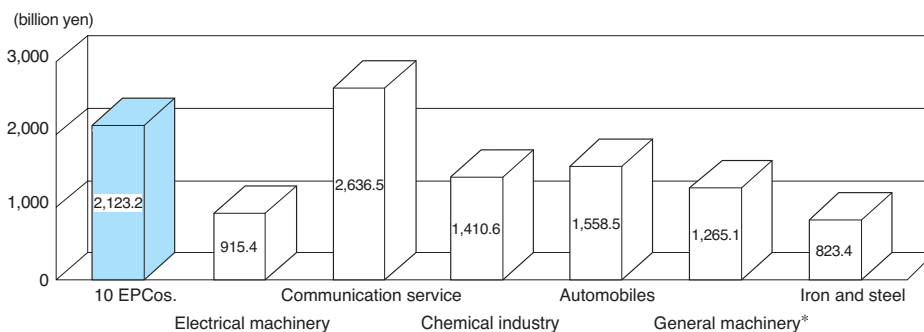

* Total amount for the "general-purpose machinery and apparatuses manufacturing industry," "production machinery and apparatuses manufacturing industry" and "business-use machinery and apparatuses manufacturing industry" combined. (The amount now includes part of the amount for the former "precision machinery and apparatuses manufacturing industry" category because of the change in the classification).

Sources: "Business Outlook Survey," Policy Research Institute, Ministry of Finance.
"Statistics of Electric Power Industry"

3. Changes in Amount of Corporate Bonds Issued

(Unit: billion yen)

FY	1985	1990	1995	1996	1997	1998	1999	2000	2001	2002	2003	2004	2005	2006	2007	2008	2009	2010	2011
Domestic Bonds	250.0	600.0	600.0	500.0	660.0	700.0	470.0	700.0	650.0	800.0	400.0	250.0	250.0	300.0	750.0	670.0	215.0	235.0	
Convertible Bonds																			
Foreign Bonds	2nd issue of U.S. dollar denominated straight bonds; US\$ 100 million			15th issue of Swiss franc denominated straight bonds; CHF 300 million	8th issue of U.S. dollar denominated straight bonds; US\$ 500 million	1st issue of Euro denominated straight bonds; EUR 750 million	2nd issue of Euro denominated straight bonds; EUR 1 billion		3rd issue of Euro denominated straight bonds; EUR 1 billion					16th issue of Swiss franc denominated straight bonds; CHF 300 million			17th issue of Swiss franc denominated straight bonds; CHF 300 million		

4. Balance of Corporate Bonds and Loans Payable

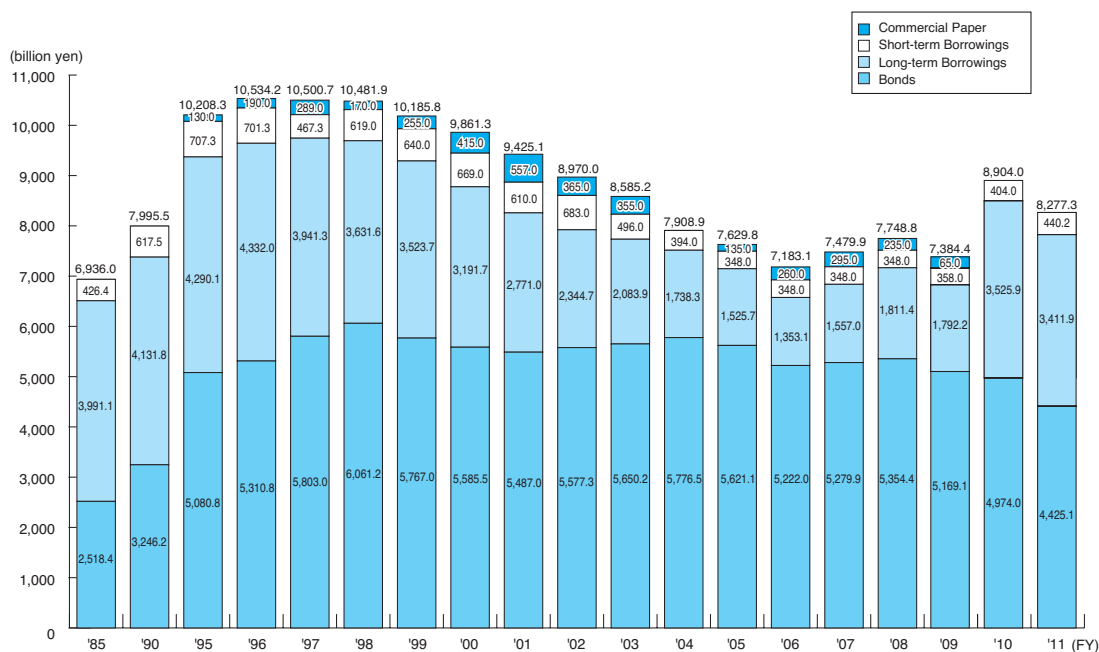

Note: Fractions smaller than 0.1 billion yen are dropped.

5. Changes in Materials Procurement Cost

(Unit: billion yen)

FY	'92	'93	'94	'95	'96	'97	'98	'99	'00	'01	'02	'03	'04	'05	'06	'07	'08	'09	'10	'11
Total Cost of Products Procurement (a)	736.7	877.4	756.4	759.0	749.5	696.4	650.7	595.8	599.9	479.3	423.2	364.2	372.6	347.6	354.7	351.4	331.4	322.7	353.9	537.7
Import Cost of Overseas Products (b)	14.0	21.6	67.5	48.0	24.6	47.1	38.7	42.2	38.2	18.1	22.8	19.2	18.9	18.9	30.2	26.9	52.0	28.9	13.0	48.0
Import Ratio (%) (b)/(a)	1.9	2.5	8.9	6.3	3.3	6.8	5.9	7.1	6.4	3.8	5.4	5.3	5.1	5.4	8.5	7.7	15.7	9.0	3.7	8.9

- Notes:
- FY1994 and FY1995: passed customs for Yokohama Thermal Power Station Units 7 and 8, and for Kashiwazaki-Kariwa Nuclear Power Station Units 6 and 7.
 - FY1997: passed customs for Chiba Thermal Power Station Unit 2.
 - FY1999: passed customs for Shinagawa Thermal Power Station Unit 1 and for Futtsu Thermal Power Station Unit 3.
 - FY2000: passed customs for Futtsu Thermal Power Station Unit 3.
 - FY2006-FY2008: passed customs for Futtsu Thermal Power Station Unit 4.
 - FY2008-FY2009: procurement cost increased a temporary basis in relation to the restoration of the Kashiwazaki-Kariwa Nuclear Power Station.
 - FY2011: procurement cost increased in relation to the restoration of Fukushima Daiichi Nuclear Power Station, etc.

MEMO

X. Streamlining

1. Changes in Electric Power Sales per Employee

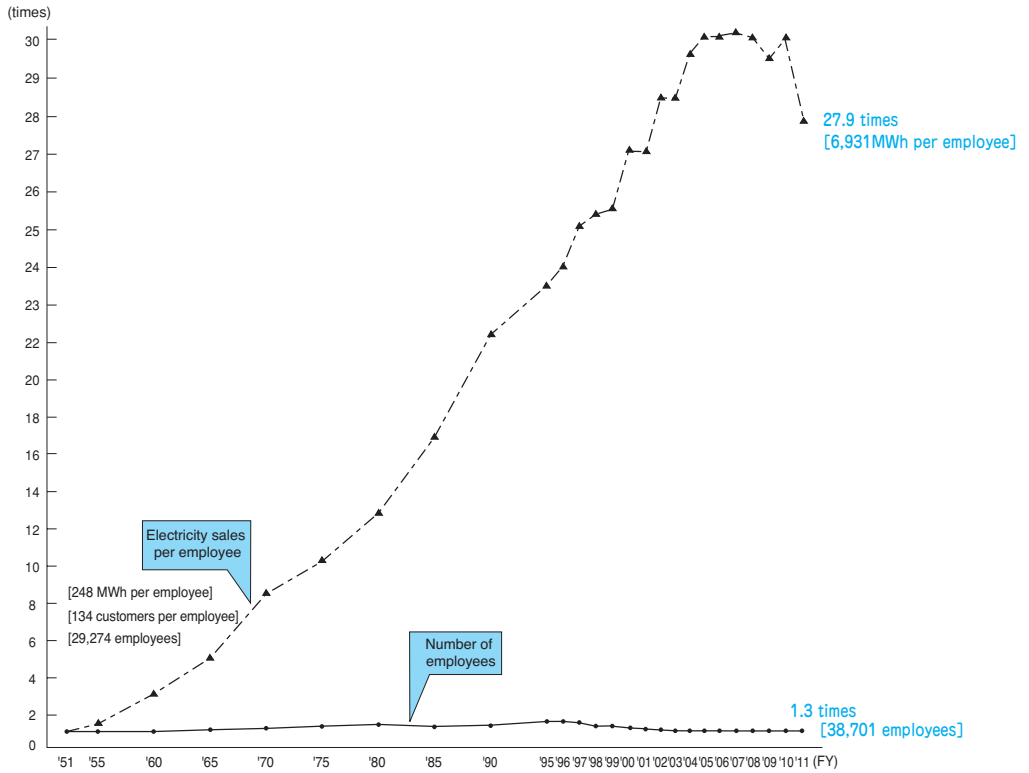

Changes in Employees

At the End of FY	1951	1955	1960	1965	1970	1975	1980	1985	1990	1995	1998	1999	2000	2001	2002	2003	2004	2005	2006	2007	2008	2009	2010	2011
Number of Employees (ratio to FY 1951)	29,274 (1)	29,453 (1.0)	29,161 (1.0)	32,724 (1.1)	36,290 (1.2)	38,341 (1.3)	40,208 (1.4)	39,058 (1.3)	39,640 (1.4)	43,448 (1.5)	42,170 (1.4)	41,882 (1.4)	41,403 (1.4)	40,725 (1.4)	39,619 (1.4)	38,950 (1.3)	38,510 (1.3)	38,235 (1.3)	38,108 (1.3)	38,234 (1.3)	38,030 (1.3)	38,227 (1.3)	38,671 (1.3)	38,701 (1.3)

Improvement of Labor Productivity

At the End of FY	1951	1955	1960	1965	1970	1975	1980	1985	1990	1995	1998	1999	2000	2001	2002	2003	2004	2005	2006	2007	2008	2009	2010	2011
Sales (MWh per employee) (ratio to FY 1951)	248 (1)	369 (1.5)	761 (3.1)	1,254 (5.1)	2,129 (8.6)	2,666 (10.8)	3,261 (13.1)	4,231 (17.1)	5,548 (22.4)	5,854 (23.6)	6,333 (25.5)	6,548 (26.4)	6,779 (27.3)	6,766 (27.3)	7,115 (28.7)	7,086 (28.6)	7,446 (30.0)	7,549 (30.4)	7,548 (30.4)	7,778 (31.4)	7,598 (30.6)	7,329 (29.5)	7,587 (30.6)	6,931 (27.9)

2. Thermal Power Generation Efficiency (LHV: Lower Heating Value)

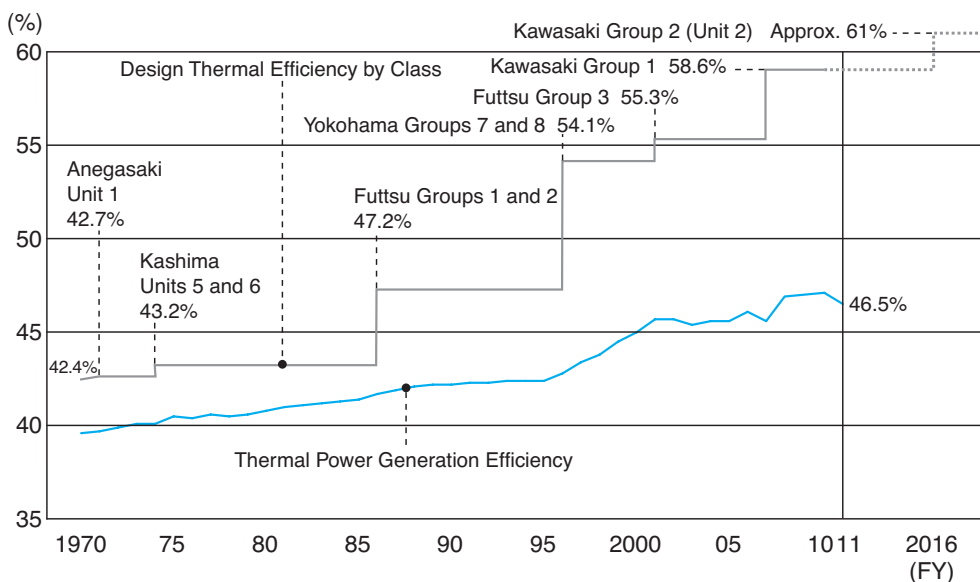

Note: Lower heating values (LHV) were estimated from higher heating values (HHV), using the conversion coefficient from General Energy Statistics (FY2004).

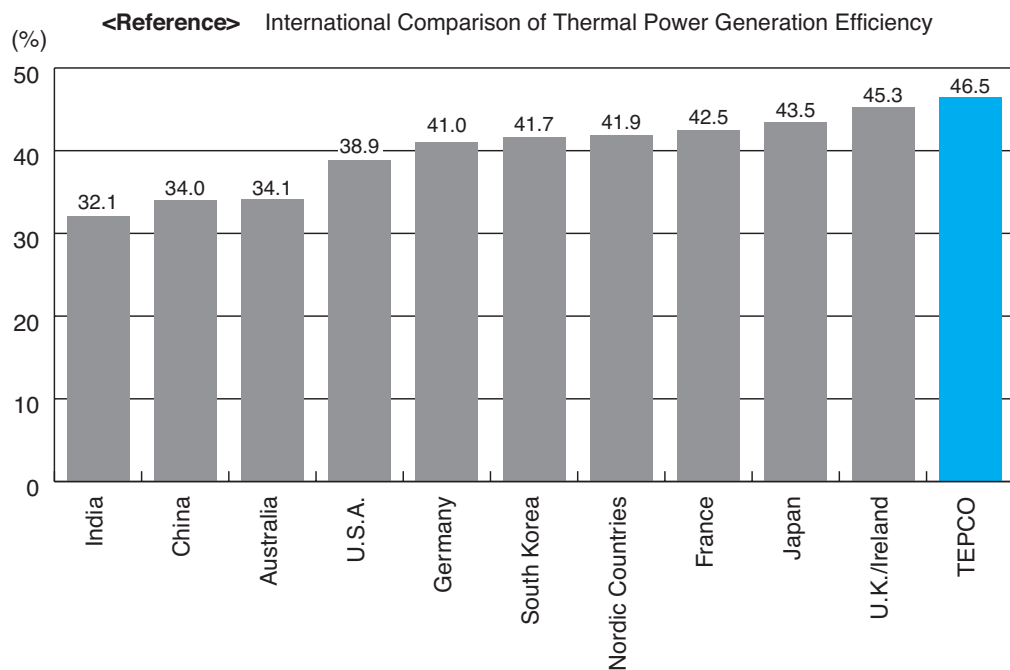

- Notes:
1. Thermal efficiency values represent weighted average thermal efficiencies of coal, oil, and gas on the power generating end (LHV standard).
 2. The thermal efficiency of independent power generation equipments, etc. are not included.
 3. The figure for TEPCO is FY2011 result. Other figures are FY2008 values. (The figure for Japan is FY2008 value.)

Source: "INTERNATIONAL COMPARISON OF FOSSIL POWER EFFICIENCY AND CO₂ INTENSITY" (2011), ECOFYS.

3. Transmission and Distribution Loss Rate

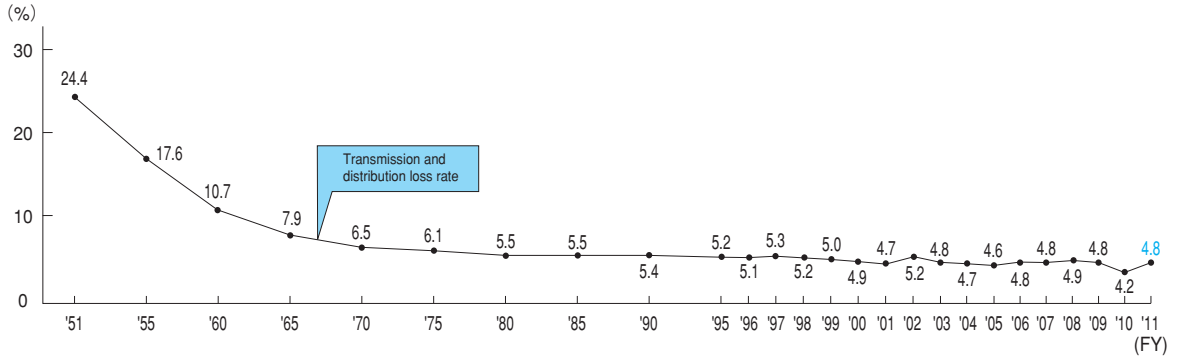

4. Changes in Automatization Rate of Hydroelectric Power Stations and Substations

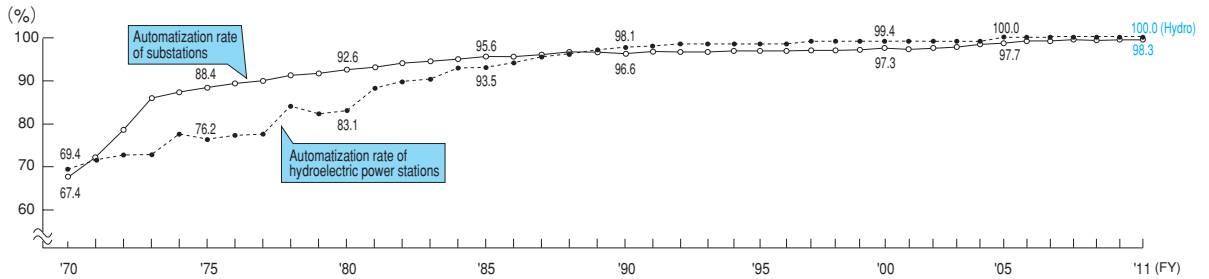

Note: Automatization rate = (Number of automatized power stations and substations / Total number of power stations and substations) × 100 (%)

MEMO

XI. Technology Development and Renewable Energy

1. Research and Development

(1) Main Themes of FY2012 Research and Development Plan

Target	Contents of Technology Development
a. Bring Fukushima Daiichi Nuclear Power Station under control in accordance with "Roadmap towards Restoration from the Accident at Fukushima Daiichi Nuclear Power Station"	Work on technology developments to bring the nuclear power station under control, study on technology to reduce radiation level, such as corrosion prevention for materials, verification of quake resistance of reactor buildings, evaluation method for facility condition, etc., and make every effort to bring the situation under control at Fukushima Daiichi Nuclear Power Station.
b. Secure stable power supply through measures for both demand and supply	Technology developments for securing power supply, such as restoration of seawater flooded thermal power plants, strengthening frequency converter facility, and restoration of damaged transmission/distribution lines; and for electricity saving, such as efficient operation of air conditioner.

(2) Changes in Research and Development Expenditure

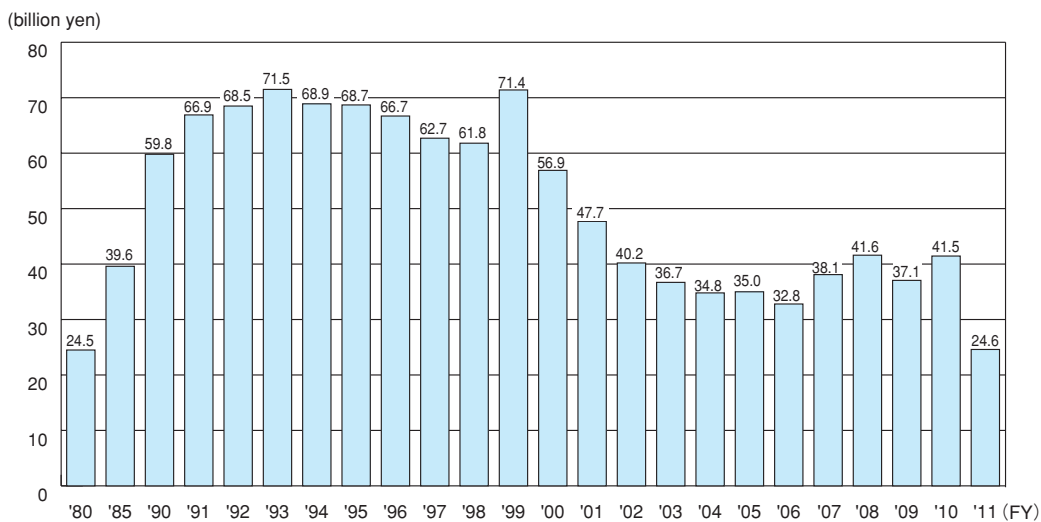

(3) Ratio of Research and Development Expenditure to Sales

FY	1980	1985	1990	1991	1992	1993	1994	1995	1996	1997	1998	1999	2000	2001	2002	2003	2004	2005	2006	2007	2008	2009	2010	2011
	0.8	1.0	1.4	1.5	1.5	1.5	1.4	1.4	1.4	1.2	1.2	1.4	1.1	0.9	0.8	0.8	0.7	0.7	0.7	0.7	0.7	0.8	0.8	0.5

(4) Changes in the Number of Patent Applications

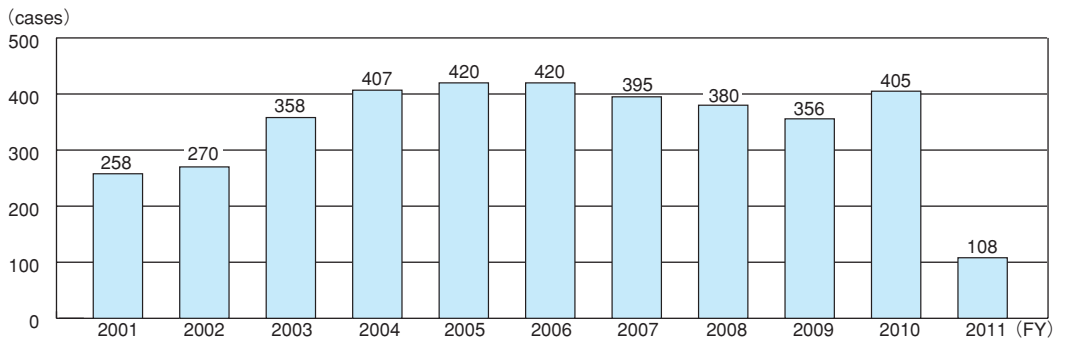

2. Renewable Energy

(1) Sites Where TEPCO Has Introduced New Energy (as of the end of March 2012)

Photovoltaic Power (Solar Power)	Futtsu Thermal Power Station, Fuji Service Center, Tsurumi Service Center, Tochigi Branch Office, Thermal Power Technical Training Center, Takasaki Service Center, Yamanashi Branch Office, Mito Service Center, Kanagawa Branch Office, Hiratsuka Service Center, Otsuka Service Center, Tama Branch Office Higashimurayama Annex, Atami Office, Tsuchiura Service Center, General Training Center, Fuji-Yoshida Sales Center, Sawara Office, Maebashi Service Center, Ueno Service Center, Tochigi-Minami Service Center, Kanuma Office, Ibaraki Branch Office, Hitachi Sales Center, Fujisawa Service Center Kamakura Office, Izu Service Center, Narita Service Center Annex, Kumagaya Service Center, Minami Yokohama Thermal Power Station, Yokohama Thermal Power Station, Yokosuka Sales Center, Tama Branch Office Fuchu Office, Komahashi Control Office, Fukushima Daini Nuclear Power Station, Tokyo Branch Office, Higashi Ohgishima Thermal Power Station, Saitama Service Center, Yamato Sales Center, Adachi Sales Center, Kazunogawa Hydroelectric Power Station (Kazunogawa Dam), Kazunogawa Hydroelectric Power Station (Kami-Hikawa River Dam), Choshi Office, Hitachinaka Thermal Power Station, Hirono Thermal Power Station, Research & Development Center (total 44 sites, 473.9kW)
Wind Power	Minami-Yokohama Thermal Power Station (0.4kW), Yokohama Thermal Power Station (4kW)

(2) Business Use Facilities (as of the end of March 2012)

Photovoltaic Power (Solar Power)	- Ukishima Photovoltaic Power Station (7,000kW) - Ohgishima Photovoltaic Power Station (13,000kW) - Komekurayama Photovoltaic Power Station (10,000kW)
Wind Power	Hachijojima Wind Power Station (500 kW)

<Reference> International Comparison of Solar Amounts and Wind Power Generation Installations in Major Countries

		Equipment Capacity (MW)
		Solar (as of the end of 2010)
①	Germany	17,370
②	Spain	3,915
③	Japan	3,618
④	Italy	3,502
⑤	U.S.A.	2,534
⑥	France	1,054
⑦	China	800
⑧	Korea	656
⑨	Australia	571
⑩	Canada	291

		Equipment Capacity (MW)
		Wind (as of the end of 2010)
①	China	44,733
②	U.S.A.	40,180
③	Germany	27,214
④	Spain	20,676
⑤	India	13,065
⑥	Italy	5,797
⑦	France	5,660
⑧	U.K.	5,204
⑨	Canada	4,009
⑩	Denmark	3,752
:		
⑬	Japan	2,304

Sources: Solar: "TRENDS IN PHOTOVOLTAIC APPLICATIONS," IEA/PVPS.

Wind: "GROBAL WIND 2010 REPORT," GWEC.

(3) Issues and TEPCO R&D Milestones

	Tasks Ahead	R&D Milestones at TEPCO
Solar Power	<ul style="list-style-type: none"> ○ Cost reduction of solar systems <ul style="list-style-type: none"> • Cost reduction of solar cells • Cost reduction of peripheral equipment, such as inverters ○ Installation, construction method ○ Development of high efficiency of solar cells ○ Establishment of utility power system interconnection technology 	<ul style="list-style-type: none"> ○ Interconnection tests were completed on pilot plants (1.4 kW and 1.7 kW, respectively) for residential use (3 kW class) and for public buildings (100 kW class). (the Engineering Research Center : November 1979 - March 1984) ○ Interconnection tests were carried out under contract with NEDO on the 200 kW dispersed arrangement system by connecting 6.6 kV of factory loads with simulated distribution lines and loads as well as a photovoltaic power generation system. (Contract period: November 1980 - March 1987) ○ The development and verification of system interconnection protective equipment, as well as researches for reducing the cost of inverters were performed. The behavior stand-alone PV system is enforced. (the Urawa solar power generation testing plant 50 kW: January 1992 - April 2002) ○ Estimation of power generation characteristics are in progress through study on influence of installing conditions and several kind of cells under the same conditions. (Research & Development Center 79 kW : November 1994 - March 2003) ○ Supply power evaluation as a power supply is enforced toward the solar system that it is installed in the general residence which a wide area dispersed around. ○ Investigation of optimal control and cost reduction method during installation of megawatt-class system is under way. ○ A project to evaluate the effects of the installation of a large number of solar power generation equipment throughout Japan on the power systems was started in April 2010 and is under way with the aid of the Ministry of Economy, Trade and Industry, with actinometers installed at 61 locations throughout Japan. (April 2010 - March 2012)
Windmill Power	<ul style="list-style-type: none"> ○ Development of operation and maintenance technologies <ul style="list-style-type: none"> • Development of windmill turbines and control programs suitable for wind conditions ○ Site selection <ul style="list-style-type: none"> • Examination of wind conditions • Area impact (scenery, noise, etc.) ○ Development of grid-connection technology <ul style="list-style-type: none"> • Refining a system analysis simulation model • Investigation of power quality characteristics ○ Establishment of offshore wind power generation technology <ul style="list-style-type: none"> • Understanding of characteristics of offshore wind conditions • Development of complete, economic offshore wind power generation system 	<ul style="list-style-type: none"> ○ Demonstration tests were carried out with the propeller type, 100 kW windmill turbines on Miyakejima Island under contract with NEDO. (Independent tests conducted in 1983 ; system interconnection tests in 1984 - 85 ; dismantling tests in 1986) ○ Researches were implemented to evaluate the performance of a 150 kW windmill power generation system made by Belgium's HMZ. (June 1986 - March 1988) ○ Demonstration tests were carried out with a 300 kW wind power plant. (TEPCO New Energies Park : July 1993 - February 2002) ○ Measurement and analysis of power quality characteristics are in progress for distribution line interconnecting with nonutility wind turbine generators in TEPCO service area. (1999 -) ○ Development of safe and economical settled-type and floating-type offshore wind power generation facilities was started in 2004 and is in progress. (2004 -) For settled-type facilities, offshore demonstration studies, including collaborative studies with NEDO and other organizations, is underway. (2009 -)
Geothermal Power	<ul style="list-style-type: none"> ○ Improvement of geothermal resource prospecting and assessment techniques ○ Improvement of drilling and collecting techniques ○ Development of technologies utilizing undeveloped geothermal resources ○ Environmental protection technologies 	<ul style="list-style-type: none"> ○ 3.3MW geothermal power plant is now in operation on the Hachijojima Island. (March 1999 -)
Fuel Cell	<ul style="list-style-type: none"> ① Polymer electrolyte fuel cell (PEFC) <ul style="list-style-type: none"> ○ Cost reduction ○ Prolonging its operation life ② Solid oxide fuel cell (SOFC) <ul style="list-style-type: none"> ○ Concentrating output ○ Cost reduction of fuel cells ○ Prolonging its operation life ○ Realizing a great capacity 	<ul style="list-style-type: none"> ○ Demonstration tests of PAFC <ul style="list-style-type: none"> • Tests were completed with demonstration plants <ul style="list-style-type: none"> Large capacity (4.5MW, 11MW) Small capacity (50kW - 220kW) 6plants ○ Molten carbonate fuel cells (MCFC) <ul style="list-style-type: none"> Participation in technical research union (May 1993 - March 2005) ○ Experimental study of fixed-type PEFC (entrusted with NEF) (November 2002 - March 2005) ○ Experimental study of SOFC (entrusted with NEF : October 2008 - December 2010, promoted with NEDO : April 2009 - March 2010)

(4) Purchase of Surplus Power from Solar, Wind and Waste Power Plants

○ Purchases (as of the end of March 2011, become effective on FY1992)

	FY1993		FY1994		FY1995		FY1996		FY1997	
	No. of Spot	Output (kW)	No. of Spot	Output (kW)	No. of Spot	Output (kW)	No. of Spot	Output (kW)	No. of Spot	Output (kW)
Solar	13	185	136	702	452	1,944	1,056	4,278	2,578	10,438
Wind	0	0	1	250	1	250	1	250	2	1,050
Waste	22	127,560	28	152,860	36	235,600	40	261,500	44	290,490
	FY1998		FY1999		FY2000		FY2001		FY2002	
	No. of Spot	Output (kW)	No. of Spot	Output (kW)	No. of Spot	Output (kW)	No. of Spot	Output (kW)	No. of Spot	Output (kW)
Solar	4,440	17,131	7,870	33,891	13,780	62,064	19,559	96,519	27,484	103,822
Wind	3	2,250	4	2,550	4	2,550	8	4,696	12	11,496
Waste	48	366,090	49	379,390	55	430,190	58	432,890	63	474,840
	FY2003		FY2004		FY2005		FY2006		FY2007	
	No. of Spot	Output (kW)	No. of Spot	Output (kW)	No. of Spot	Output (kW)	No. of Spot	Output (kW)	No. of Spot	Output (kW)
Solar	39,872	146,292	56,698	207,540	75,195	272,735	92,977	334,959	107,846	385,207
Wind	17	36,243	25	55,415	52	66,310	42	184,620	47	214,600
Waste	63	471,740	61	437,240	58	334,227	60	341,217	59	330,818
	FY2008		FY2009		FY2010		FY2011			
	No. of Spot	Output (kW)	No. of Spot	Output (kW)	No. of Spot	Output (kW)	No. of Spot	Output (kW)	No. of Spot	Output (kW)
Solar	123,649	437,171	159,883	565,204	217,996	787,213	298,731	1,117,785		
Wind	46	224,546	48	243,146	53	351,148	52	349,168		
Waste	55	285,818	54	276,208	53	273,488	54	282,688		

<Reference> Purchase of Electricity from Solar and Wind Power

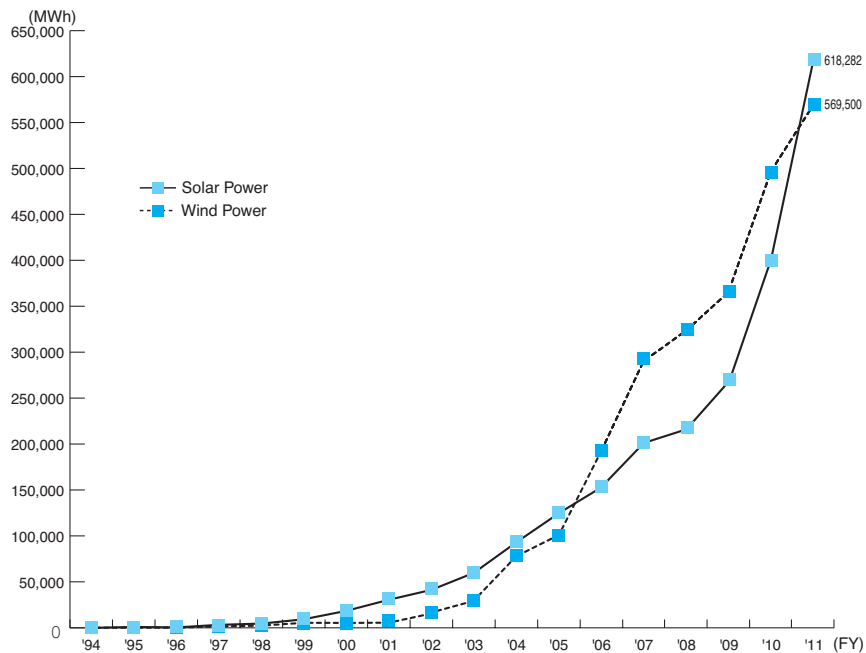

XII. Environmental Protection Measures

1. Changes in SOx and NOx Emissions Intensity per Power Output from Thermal Power Stations

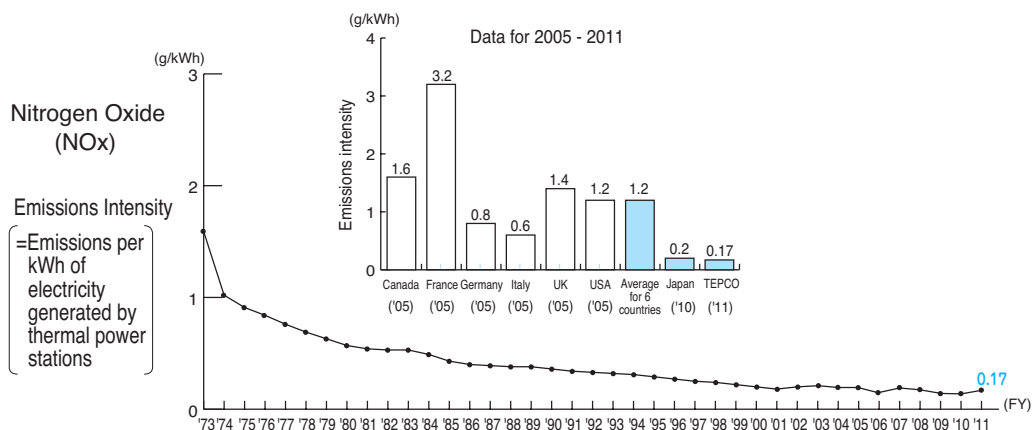
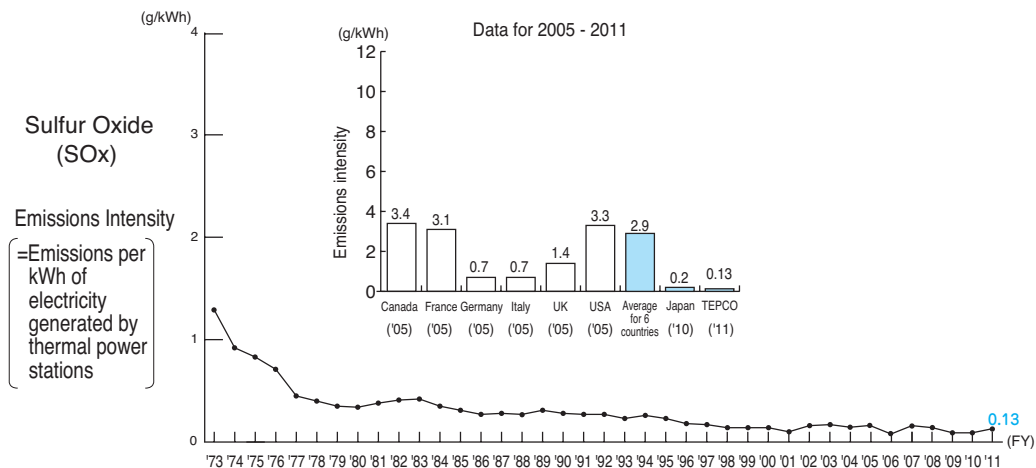

Sources: Estimates are based on IEA, "OECD Environmental Data Compendium 2006/2007" and "Energy Balances of OECD Countries 2011 edition."

Figures for Japan are based on a survey of the Federation of Electric Power Companies.

<Reference> CO₂ Emissions per kWh of Electricity Usage (for Life Cycle CO₂ by type of power source in Japan)

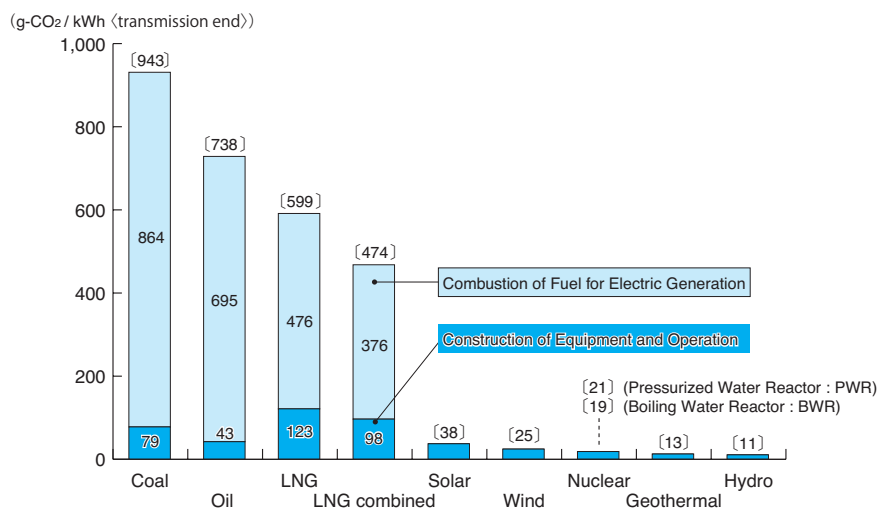

Notes: 1. The amounts of emitted CO₂ shown are the calculated amounts of CO₂ emitted as a result of the combustion of fuels for power generation and the consumption of (all kinds of) energies for the associated mining, power generation facility construction, fuel transport and purification and operation and maintenance of facilities. The amount of emitted CO₂ for nuclear power was calculated taking into consideration the planned domestic reprocessing of spent fuels and use of plutonium (on the premise that the number of times of recycling is one), as well as the generation of high-level radioactive wastes.

2. Totals may not agree with the sum because of being rounded off.

Source: "Report of Central Research Institute of Electric Power Industry"

2. Changes in TEPCO's CO₂ Emissions and Emissions Intensity

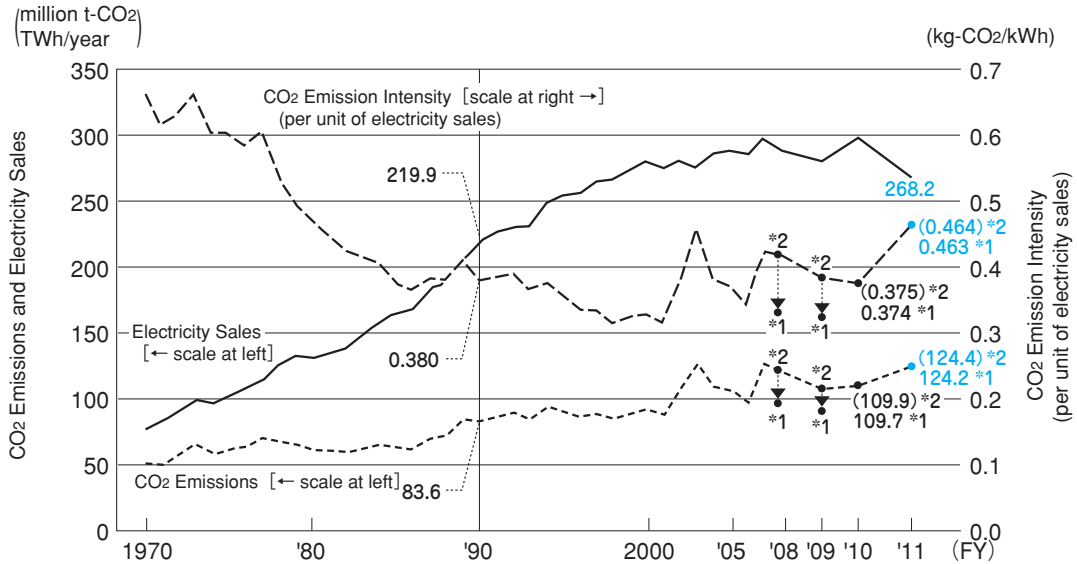

*1 Values reflecting carbon credits.

*2 Values without carbon credits.

Note: TEPCO's CO₂ emission intensity values were calculated in accordance with the "System for Calculating, Reporting and Publishing Greenhouse Gas Emissions" established pursuant to the "Act on Promotion of Global Warming Countermeasures." The System does not take into account CO₂ reduction values such as those created by tradable green certificates.

<Reference> List of CO₂ Emission Factor for Each Company (FY2010)

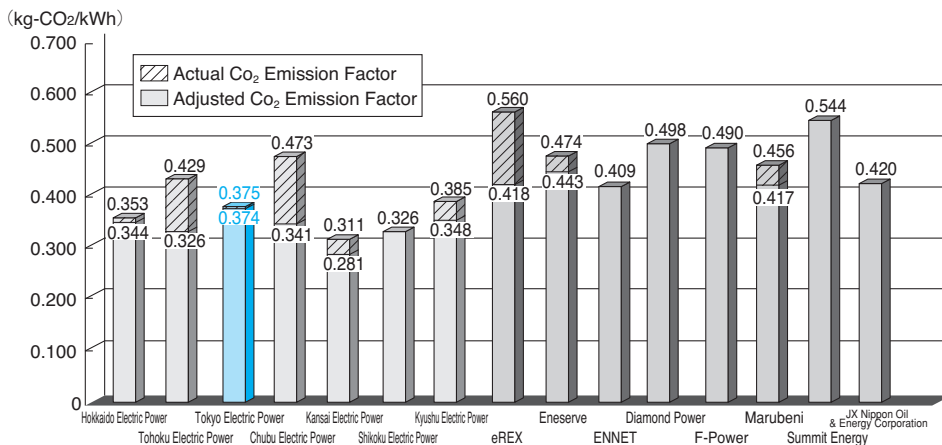

* CO₂ emission factor published based on the "Law Concerning the Promotion of the Measures to Cope with Global Warming" (published by Ministry of the Environment on January 17, 2012)

3. Internal Environmental Costs (for TEPCO alone in FY2011)

(Unit : billion yen)

Environmental Preservation Measures		Investments	Expenses	Major Details	
Environmental Management	Enhancement of organization and employee education	-	2.9	Personnel expenses, support for employees to obtain qualifications in the environmental field and training.	
	Improvement of environmental management system	-	-	Acquisition of certificates from outside organizations, and preparation of environment reports.	
	Green procurement and purchasing	-	-	Purchase of materials, equipment, products, etc. with consideration given to the environment.	
Global Environmental Preservation	Mitigation of global warming	5.8	33.1	Introduction of natural energy	
	Protection of ozone layer	-	-	Reduction of regulated chlorofluorocarbons (CFCs).	
Regional Environmental Preservation	Environmental impact measurement and monitoring	0.4	0.6	Environmental impact assessment and environmental load measurement.	
	Environmental pollution control	Air pollution control	20.2	44.4	Flue gas desulfurization and denitrification, combustion improvement, installation of electrostatic precipitators and fuel measures.
		Water pollution control	2.2	2.5	Effluent treatment, prevention of oil leakage and measures to deal with thermal effluent.
		Noise and vibration control	3.2	0.1	Facility measures (e.g., installation of inlet silencers) and measures during construction work (e.g., use of innovative engineering methods).
		Soil contamination and land subsidence control, etc.	-	0.0	Land subsidence measurements and water quality monitoring.
	Management of radioactive substances	-	12.7	Treatment of radioactive substances, and radiation control and measurement.	
	Nature conservation and harmony with the environment	Natural environment protection	0.5	1.2	Afforestation of TEPCO's establishments and nature conservation activities in the Oze marshland.
		Landscaping and urban space measures	43.2	-	Construction of underground transmission and distribution facilities and consideration to the configurations and color schemes of facilities.
Technology Developments		-	9.2	Research and development for reducing environmental loads and related to generation facility.	
Resource Recycling	Reduction in waste production and waste recycling	0.0	9.4	Reduction in quantity, storage, treatment and recycling of waste, and their disposal in landfills.	
Social Contributions	Cooperation with communities	-	0.3	Community beautification and afforestation activities, and environment related donations and support.	
	Environmental education support and publicity activities	-	-	Environmental education support activities and environmental advertisements.	
Others	Environment-related charges, etc.	-	2.4	Pollution load charges (under the pollution related health damage compensation program).	
Total (reference)		75.6	118.8		

- Notes:
1. Figures do not include a part of the cost related to the nuclear power plant.
 2. Expenses do not include depreciation costs.
 3. Costs for power generation systems for hydro-electric, nuclear and LNG thermal power, which contribute to the reduction of CO₂ emissions, are excluded since they cannot be regarded as an additional cost for environmental protection.
 4. Totals may not agree with the sum because of being rounded off.

4. TEPCO's Efforts Toward Recycling of Industrial Waste etc.

<Major industrial waste, etc. by type> (FY2011)

Type of Waste	Waste Produced*1 (1,000 t/year)	Recycling Application
Coal ash	432.2	Land reclamation material, cement raw material, etc.
Scrapped concrete utility poles	112.9	Roadbed material, etc.
Gypsum recovered through desulfurization	71.9	Building material, cement raw material, etc.
Metal scrap	34.2	Metal recovery, etc.
Heavy / Crude oil ash	4.5	Metal recovery, cement raw material, etc.
Waste oil	4.2	Fuel substitute, heat recovery, etc.
Wastewater treatment sludge*2	4.1	Roadbed material, cement raw material, etc.
Shells	3.8	Cement raw material, roadbed material, etc.
Insulator scrap	2.1	Roadbed material, building material etc.
Waste plastics	1.3	Plastic recycling, heat recovery, etc.
Thermal insulation material scrap	0.9	Roadbed material, etc.
Others	17.1	—
Total	689.4	

*1 Waste produced = salvaged material + material reused in-house + industrial waste

(Radioactive waste, which is governed by laws concerning nuclear power, is not included in industrial waste, etc.)

*2 Weight after dehydration.

Note: The total above may not agree with the sum of each column because of being rounded off.

<Changes in Recycling Rate* of Industrial Waste, etc. and Landfill Disposal Volume>

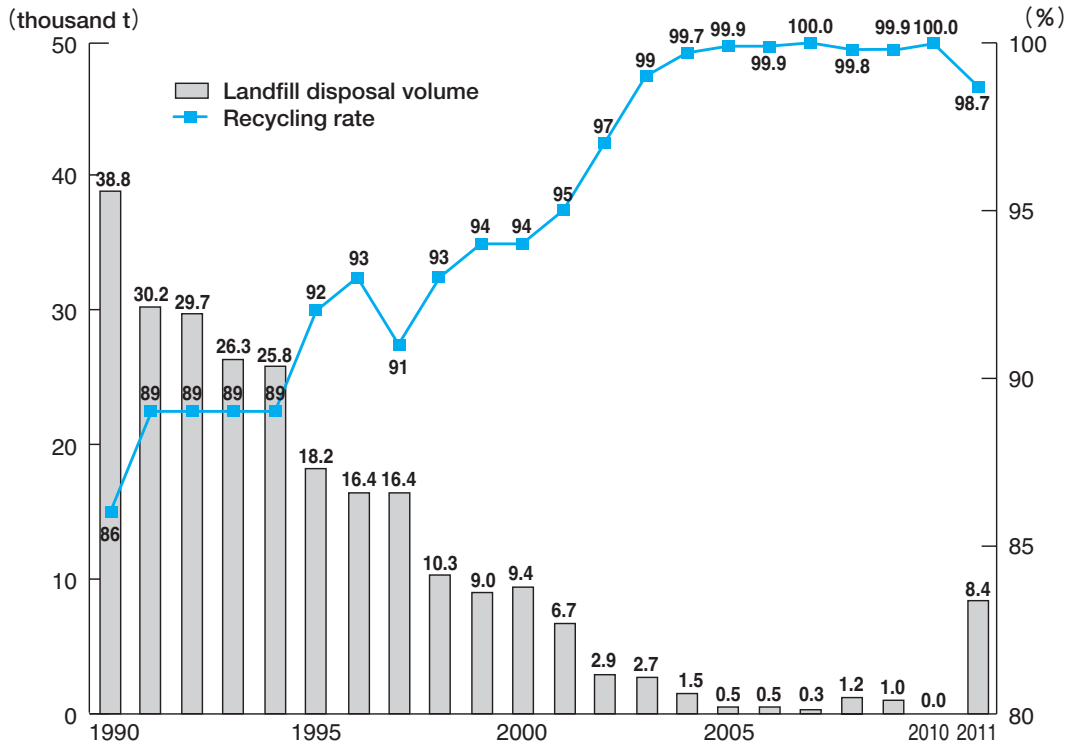

* Recycling rate (%) =
$$\frac{\text{Amount recycled (Incl. the amount of valued items and of materials internally recycled)}}{\text{Amount produced}} \times 100$$

Figures are rounded off to the first decimal place.

5. Overview of PCB Treatment Facilities

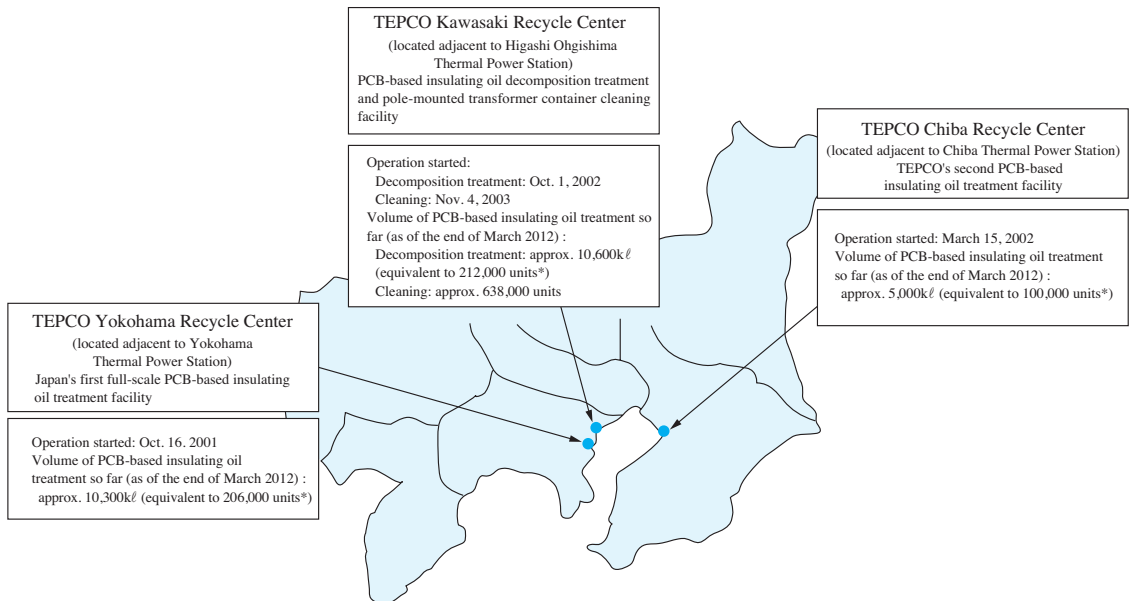

* When converted to number of pole-mounted transformers with average capacity (30kVA ; oil volume 50ℓ)

Number of Electric Equipments with PCB Owned by TEPCO (survey results as of the end of FY2011)

		Number of Electric Equipments on Hand
Trace PCB Contaminated Equipments	Pole-Mounted Transformer (thousand units)	approx. 462
High Concentration PCB Contaminated Equipments	High-Voltage Transformer-Capacitor* (units)	approx. 3,000

* These equipments are treated by Japan Environmental Safety Corporation (JESCO).
Excluding equipments less than 10kg.

MEMO

XIII. Energy Conservation and Recycling

1. Total Energy Efficiency of District Heating and Cooling (DHC) Services (within the TEPCO service area)

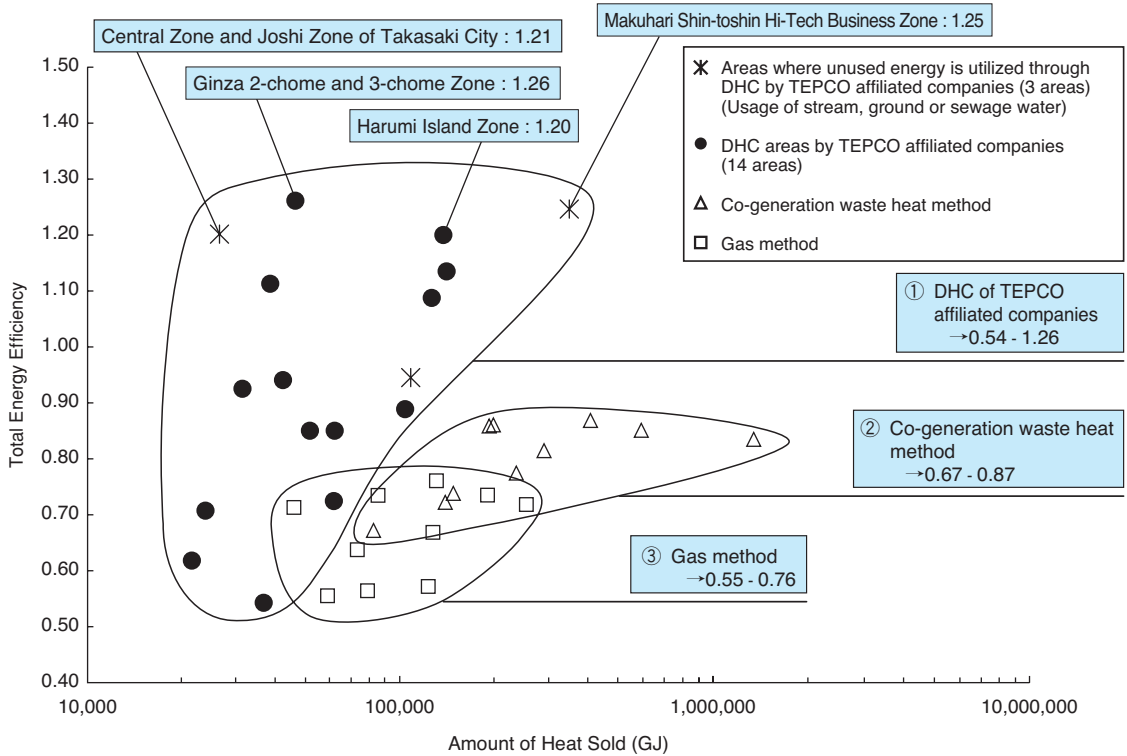

Total Energy Efficiency		
	DHC areas by TEPCO subsidiaries and affiliated companies	0.54 - 1.26
①	A. Usage of stream, ground or sewage water	0.95 - 1.25
	B. Others	0.54 - 1.26
②	Co-generation waste heat method	0.67 - 0.87
③	Gas method	0.55 - 0.76

Notes: • Areas of co-generation system-installed power plants were excluded.
 • Total energy efficiency= Amount of heat sold (GJ) / Amount of raw fuels used (GJ)

Source: "Heat Supply Industry Manual 2011 edition" (actual achievement value in FY2010)

2. CO₂ Emission per Amount of Heat Unit Sold in District Heating and Cooling (DHC) Services (within the TEPCO service area)

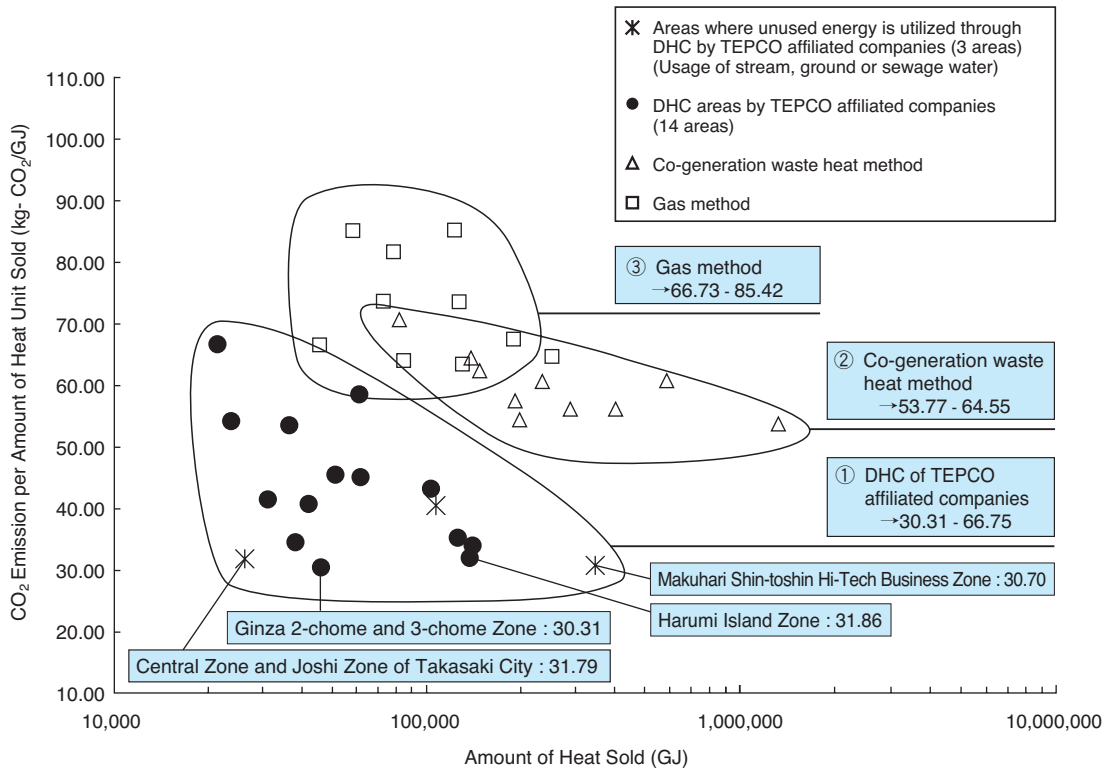

- Notes:
- Areas of co-generation system-installed power plants were excluded.
 - CO₂ emission per amount of heat unit sold = CO₂ emission (kg-CO₂) / Amount of heat sold (GJ)

Source: "Heat Supply Industry Manual 2011 edition" (actual achievement value in FY2010)

3. Energy-IIP Intensity by Industry

(FY1973=100)

Industry Type	Manufacturing	Iron and Steel	Chemical	Paper and Pulp
Reduction of energy consumption per unit of output (FY2010)	58.7	68.9	50.3	48.4

Note: IIP = Indices of Industrial Production

Source: "Handbook of Energy & Economic Statistics in Japan (2012 edition)," The Energy Data and Modelling Center (EDMC).

4. Energy Conservation for Major Household Electrical Appliance

(1) Breakdown of Energy Consumption by Electrical Appliance in Homes

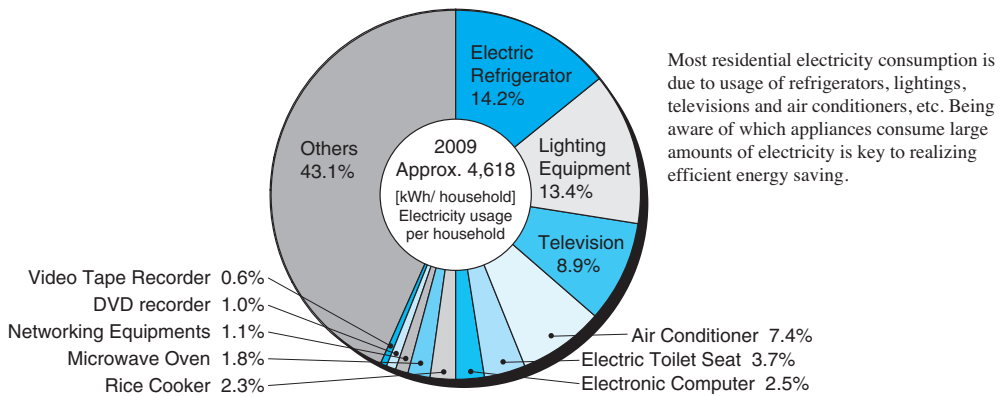

Source: Calculation of the Institute of Energy Economics, Japan based on the two materials released from Agency for Natural Resources and Energy: Energy consumption survey of the private sector, FY2009 (effective answers: 10,040), Supplemental survey concerning the use of equipment (effective answers: 1,448)
(Note: As for "air conditioner," the value includes the effect of cool summer and mild winter in 2009.)

- Air conditioner (simple average value of representative models of cooling and heating, wall-hanging type, cooling ability 2.8kW class and energy-saving type)

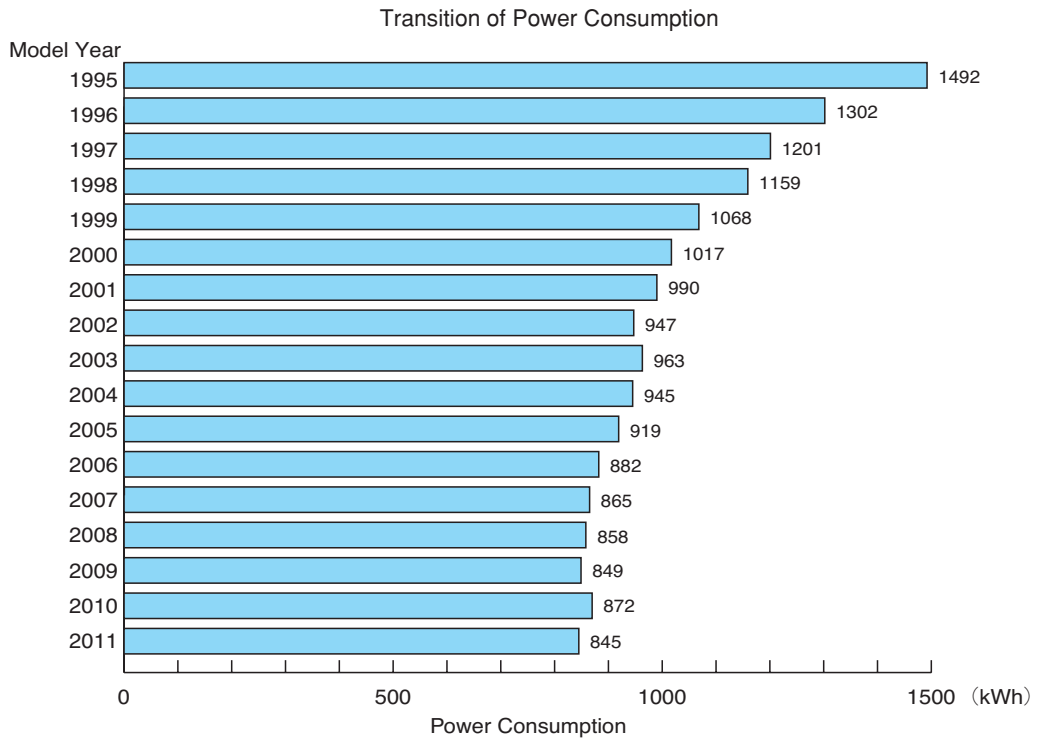

Sources: The Japan Refrigeration and Air Conditioning Industry Association
"Energy Efficiency Catalog 2012 summer edition," Agency for Natural Resources and Energy.

(2) Data on Household Electrical Appliances

No.	Appliance	Electric Power Usage		Timer Function
		Usage Conditions	Electric Power (kWh)	
1	Fluorescent lamp (20W)	Turned on 10 hours	0.18 *	
	Fluorescent lamp (30W)	Turned on 10 hours	0.28 *	
2	Incandescent lamp (60W)	Turned on 10 hours	0.54	
3	Compact fluorescent lamp (light bulb shape) (60W type)	Turned on 10 hours	0.10	
4	LED lamp (general light bulb shape) (9.2W type)	Turned on 10 hours	0.09 *	
5	Induction heating (IH) rice cooker (1.0L) (while cooking rice)	Cooking rice 1 time (white rice 3 cups)	0.19	○
	IH rice cooker (1.0L) (while keeping rice warm)	Keeping rice warm 10 hours (white rice 3 cups)	0.21	○
6	Microwave oven (tabletop type)	Heating 200 grams of spinach for 3 minutes at 500W (without water)	0.05	
7	IH cooking heater (100V)	18 cm enameled steel pan, heating 20°C water to 90°C	0.18	
	IH cooking heater (200V)	18 cm enameled steel pan, heating 20°C water to 90°C	0.17	
8	Toaster	Using for about 3 minutes on automatic toast menu	0.05	
9	Refrigerator (415L)	Electricity Consumption of new JIS-based refrigerator for one month (31 days) with room temperature 22°C, with temperature setting "refrigerating room 4°C, refrigerated room -18°C", and with the door opened and closed	26.7	
10	Electric kotatsu (heated table)	Used 1 hour at "medium" setting	0.10	
11	Electric blanket	Used 1 hour at "medium" setting	0.03	
12	Electric carpet (2 tatami mat room)	Used 1 hour at "medium" setting	0.21	○
13	Electric fan	Used 1 hour in "high" mode	0.04	○
14	Air conditioner for 13 - 20 square meter area (8-12 tatami mat room) (cooling)	Average electricity consumption per hour when using 10 hours (Average electricity consumption per hour when using for 10 hours with preset room temperature of 33°C and heat load of 2.2kW)	0.39	○
	Air conditioner for 13 - 20 square meter area (8-12 tatami mat room) (heating)	Average electricity consumption per hour when using 10 hours (Average electricity consumption per hour when using for 10 hours with preset room temperature of 10°C and heat load of 3.1kW)	0.84	○
15	Vertical washing and drying machine [heater drying system] (washing capacity 8kg, drying capacity 4.5kg)	For "washing to draining" one 4.5kg load of laundry (Water temperature: 20°C)	0.06	○
	Drum type washing and drying laundry machine [heater drying system] (washing capacity 9kg, drying capacity 6kg)	For "washing to drying" one 4.5kg load of laundry (Water temperature: 20°C)	2.81	○
	Drum type washing and drying machine [heat pump drying system] (washing capacity 9kg, drying capacity 6kg)	For "washing and drying" one 4.5kg load of laundry (Water temperature: 20°C)	1.51	○
16	Clothes dryer (5.0kg)	For "drying" one 4.5kg load of laundry in standard cycle (the load specified by Japan Electrical Manufacturers' Association).	2.73	○
17	Iron	Using 10 minutes on "high" setting	0.09	
18	Vacuum cleaner	Used 15 minutes in "high" mode	0.23	
19	Hair dryer	Using 5 minutes, with warm air	0.09	
20	LCD TV (37V)	Watching a movie for 1 hour	0.21	○
	Plasma TV (42V)	Watching a movie for 1 hour	0.35	○
21	Stereo (MD component)	Listening to CD for 1 hour	0.03	
22	DVD video recorder	Watching a movie for 1 hour	0.03	○
23	Garden light (mercury lamp) (40W)	Turned on 10 hours	0.40 *	
24	Dishwasher / dryer (tabletop type)	Washing dishes for 6 people (about 85 minutes) in standard cycle (wash/dry)	0.90	○
25	Air purifier	Used 1 hour	0.05	○
26	Dehumidifier (compressor type)	Used 1 hour	0.19	○
27	Humidifier (hybrid type)	Used 1 hour	0.39	○

- Notes:
1. Items marked with an asterisk use values from the manufacturer's catalog.
 2. The above energy consumption figures were found by measuring typical models from manufacturers with a large market share.

XIV. Related Businesses

1. Affiliated Companies

(as of the end of March 2012)

		Company Name	Description of Major Business	Date Established (month/year)	Capital (million yen)	Employees (including temporary workers)	Phone
Electricity	Power Generation	The Tokyo Electric Generation Company, Incorporated	Supplying electricity from hydroelectric power	July 1928	2,500	245	03-6371-5200
		Kimitsu Cooperative Thermal Power Company, Inc.	Supplying electricity from thermal power	June 1967	8,500	115	0439-52-1361
		KASHIMA KYODO ELECTRIC POWER Co., Ltd.	Supplying electricity from thermal power	December 1969	22,000	138	0299-75-5400
		Soma Kyodo Power Company, Ltd.	Supplying electricity from thermal power	June 1981	112,800	153	0244-36-1200
		Joban Joint Power Co., Ltd.	Supplying electricity from thermal power	December 1955	56,000	173	03-3256-5411
		The Japan Atomic Power Company	Supplying electricity from nuclear power	November 1957	120,000	1,363	03-6371-7400
Information Communication	Telecommunications	FAMILYNET•JAPAN CORPORATION	Internet connection service for multi-unit housing (condominiums, etc.)	October 2000	270	87	03-5774-1400
	Cable Television Broadcasting	TEPCO CABLE TELEVISION Inc.	Cable television and radio broadcasting	November 1989	100	54	048-638-7000
	IT Software and Services	TEPCO SYSTEMS CORPORATION	Computer system planning, development, maintenance and operation	July 1977	350	1,663	03-6364-1117
		Tepco Office Service Corporation	Information processing service business related to electricity rate etc.	June 1999	10	1,308	03-6371-1300
		AT TOKYO Corporation	Data center service	June 2000	13,378	235	03-6372-3000
		TOKYO RECORDS MANAGEMENT CO., INC.	Commissioned production, storage, management of information records	September 1987	20	339	03-6372-0200
		Japan e-Market Co., Ltd.	Electronic marketplace	December 2000	1,500	12	03-5977-2230
Construction and Maintenance of Information Communication Equipment	TEPCO OPTICAL NETWORK ENGINEERING INC.	Construction and maintenance operation for FTTH-related equipment in electricity-related facility (transformer station etc.), connection of optical fiber cable, construction work for diverging devices	December 2006	150	210	03-3432-5770	

		Company Name	Description of Major Business	Date Established (month/year)	Capital (million yen)	Employees (including temporary workers)	Phone
Energy and Environment	Facility Construction and Maintenance	TODEN KOGYO CO., LTD.	Inspection and maintenance of thermal and nuclear power generation equipment, construction and maintenance of power transmission and conversion equipment and civil engineering and construction equipment, nonlife insurance agent	April 1954	300	1,299	03-6372-4800
		Tokyo Electric Power Environmental Engineering Company, Incorporated	Thermal and nuclear power station environmental protection, facility operations and maintenance, industrial waste, environmental studies, measurements and assessments	November 1955	300	1,290	03-6372-7000
		Tokyo Electric Power Services Company, Limited (TEPSCO)	Civil engineering, construction and electric facility design and supervision	December 1960	40	600	03-6372-5111
		Tokyo Densetsu Service Co., Ltd.	Power generation, transmission and conversion equipment patrolling, inspection and repair	September 1979	50	804	03-6371-3000
		Tokyo Electric Power Home Service Company, Limited (TEPCO HOME SERVICE CO., LTD.)	Turnover operation, publicity of blackout, design, inspection tour and check of distribution installation, completion check after the construction of distribution installation, safety inspection, etc.	September 1982	200	2,229	03-6372-6060
		TOSETSU CIVIL ENGINEERING CONSULTANT Inc.	Civil engineering construction service	October 1983	10	78	03-5805-7261
		SHIN-NIHON HELICOPTER CO., LTD.	Patrolling of power transmission lines by helicopter, shipping of construction materials	July 1960	250	98	03-3567-3206
		KANDENKO CO., LTD.	Construction and maintenance of power generation transmission, conversion and distribution facilities and communication facilities, thermal power and nuclear power station electric and instrumentation work, internal phone line and air conditioning system work	September 1944	10,264	6,898	03-5476-2111
		TOKYO ENERGY & SYSTEMS INC.	Planning, study, design, and construction of thermal power plants, nuclear power plants, hydro power plants, substations, etc.; design and construction of civil and architectural facilities; planning, study, design, and construction of telecommunication system and electronic facilities	August 2010	2,881	1,277	03-3434-0151
		JAPAN NUCLEAR SECURITY SYSTEM CO., LTD.	Design building, leasing and operation of scientific security systems for nuclear power-related facilities, security for nuclear fuel shipping	July 1977	200	510	03-6372-0300
	Transmission Line Construction Co., Ltd. (TLC)	Construction of electric facilities for power transmission, communication, etc.	May 2002	98	230	03-4366-1500	
	Supply and Transportation of Materials and Equipment	Tokyo Keiki Kogyo Co., Ltd.	Repair and replacement of business meters	April 1951	100	231	03-6372-4220
		TODEN Lease Corporation	Automobile leasing, lease of institutional use electric appliance etc.	June 1957	100	128	03-6371-8600
		TEPCO LOGISTICS CO., LTD.	Transportation of power distribution materials, management of materials warehouse, etc.	July 1977	50	534	03-6361-7900
		TOKO ELECTRIC CORPORATION	Electric machinery and appliance manufacturing and sales, repair and replacement of business meters, electric utility work in buildings and other construction	September 1928	1,452	881	03-6371-4380
		TAKAOKA ELECTRIC MFG. CO., LTD.	Manufacture, construction, repair and sales of substation equipment, transformers, SF6 gas insulated transformers, power equipment remote monitoring system and high speed 3-dimensional inspection system for electronics applications, etc.	March 1918	5,906	1,307	03-6371-5000
		Toshiba Toko Meter Systems Co., LTD	Development, production and sales of measuring instruments (including some components of measuring instruments)	December 2009	480	204	03-6371-4330

		Company Name	Description of Major Business	Date Established (month/year)	Capital (million yen)	Employees (including temporary workers)	Phone
Energy and Environment	Supply and Transportation of Fuel	TEPCO RESOURCES INC.	Uranium excavation and refining	April 1997	107,700 C\$1,000	0	-
		TEPCO Australia Pty. Ltd.	Investment and financing in overseas project companies	March 2003	51,000 US\$1,000	7	-
		TEPCO Trading Co., Ltd.	Purchase and sales of LNG	January 2006	100	2	03-3597-0230
		Fuel TEPCO	Sales and marine shipping of heavy oil, etc., thermal power station disaster prevention and security, LNG import representative operation	March 1955	40	554	03-6371-2600
		Recyclable-Fuel Storage Company	Storage and management of spent fuel from nuclear power plants, and incidental businesses	November 2005	3,000	49	0175-25-2990
		Pacific LNG Shipping Limited	Ownership of LNG tankers	December 2000	3,755	0	-
		Pacific LNG Yuso Limited	Operation and management of LNG tankers	April 2001	95	0	03-5501-7181
		Pacific Eurus Shipping Limited	Ownership of LNG tankers	February 2002	3,740	0	-
		Transocean LNG Yuso Limited	Operation and management of LNG tankers	December 2002	95	0	03-5501-7181
		LNG Marine Transport Limited	LNG marine transport service	October 2004	460	10	03-5501-7181
		Cygnus LNG Shipping Limited	Ownership of LNG tankers	November 2005	4,002	0	-
		Tokyo Timor Sea Resources Inc. (U.S.A.)	Stock owned by Tokyo Timor Sea Resources Pty Ltd (Australia)	June 2003	39,000 US\$1,000	4	-
		TEPCO Darwin LNG Pty. Ltd.	Investment in plant and pipeline projects of Bayu-Undan gas field development project	March 2003	62,483 A\$1,000	-	-
		Tokyo Timor Sea Resources Pty. Ltd. (Australia)	Participation in gas field development projects	June 2003	316,668 A\$1,000	-	-
		NANSO SERVICE CO., LTD.	Thermal power station disaster prevention and security, fuel payment acceptance	August 1979	20	93	0240-27-2497
		Japan Uranium Management Inc.	Owns shares of Uranium One Inc (in Canada)	January 2009	275,500 C\$1,000	0	-
		Pacific Hope Shipping Limited	Ownership of LNG tankers	August 2005	4,071	0	-
		Japan Nuclear Fuel Limited	Reprocessing of spent nuclear fuel	March 1980	400,000	2,369	0175-71-2000
		Japan Coal Development Co., Ltd.	Surveying, exploration, development, import and sales of coal resources overseas for electric power	January 1980	5,200	20	03-5461-7535
		Nuclear Fuel Transport Company, Ltd.	Handling and land and marine transport of spent fuel, radioactive waste, etc. from nuclear power stations, etc., as well as related cargo shipping and handling, ship transportation, etc.	April 1973	1,600	131	03-3438-3241
SAP-Japan Co., Ltd.	Invests to a management company (in Kazakhstan) of sulfuric acid manufacturing plants	December 2008	10	0	-		
CELT Inc.	Purchase and sales of LNG	January 2006	100	0	-		

		Company Name	Description of Major Business	Date Established (month/year)	Capital (million yen)	Employees (including temporary workers)	Phone
Energy and Environment	Energy and Environmental Solution	TOKYO TOSHI SERVICE COMPANY	Operation, maintenance and management of heat supply equipment	September 1987	400	280	03-6361-5100
		Bio Fuel Co., Inc.	Fuel processing facility planning, design, building, operations and maintenance, and development of biomass and other renewable resources	March 2005	490	22	03-5665-9120
		TOKYO WATERFRONT RECYCLE POWER CO., LTD.	Power generation from gasification/ melting, etc. at Tokyo Super Ecotown Project	December 2002	100	67	03-6327-3190
		KAWASAKI STEAM NET CO., LTD.	Sales and supply of steam, design, construction, operation, maintenance and management of equipment such as steam supply piping	October 2006	160	0	045-321-4682
		Morigasaki Energy Service Co., Ltd.	Electric power and hot water supply and power load adjustment for Tokyo Bureau of Sewerage Morigasaki Wastewater Treatment Center	October 2002	310	2	03-3741-7805
		Isehara Energy Service Co., Ltd.	Electric power, cold water, steam and other energy supply to Tokai University Isehara Campus	March 2003	150	0	-
		Hitachi Heat Energy Co., Ltd.	Heat supply business	March 1988	250	11	0294-24-6338
		Japan Natural Energy Company Limited	Providing environmental value through "Green Electric Power Certificate System" and "Green Heat Certificate System"	November 2000	395	6	03-3510-0351
		Haneda Solar Power Co., Ltd.	Energy supply service to cargo terminals for international airlines in Haneda Airport utilizing photovoltaic power	September 2008	5	0	03-6372-4849
		JAPAN FACILITY SOLUTIONS, Inc.	ESCO services, diagnoses and consulting, facility renovation	December 2000	490	57	03-5229-2911
		AOYAMA ENERGY SERVICE Co., Ltd.	Heat supply business	August 1989	300	5	03-3497-8008
		CLEAN COAL POWER R&D CO., LTD.	All tasks incidental to testing and research of IGCC (integrated gasification combined cycle) power generation	June 2001	100	61	0246-77-3111

		Company Name	Description of Major Business	Date Established (month/year)	Capital (million yen)	Employees (including temporary workers)	Phone
Living Environment and Lifestyle-Related	Real Estate	TODEN REAL ESTATE Co., Inc.	Rental and management of office space, company housing and housing for single individuals	April 1955	3,020	360	03-6372-1010
		TEPCO Land Management Corporation	Utility pole site work, management of power transmission line sites and other land owned by TEPCO, acquisition of power transmission line sites	October 2008	100	693	03-6371-1100
		Toso Real Estate Management Co., Ltd.	Leasing/ borrowing, purchase, sale and brokering of real estate, and management, repair, security, cleaning, etc. of real estate	October 1982	20	141	0240-32-5596
		Mutsu-Ogawara Habitat Inc.	Ownership, management, sale and brokering of real estate, and management, repair, security, cleaning, etc. of real estate	November 1991	100	5	0175-72-3776
		Toden Facilities Co., Ltd.	Construction contracting, design and supervision, land and building maintenance and management	December 1966	90	118	03-6371-6800
	Service	OZE Corporation	Protection and study of natural environment, planting of vegetation, in Oze/ Urabandai area, etc.	February 1951	60	102	03-6371-1000
		CareerRise Corporation	Job placement, temporary staffing	June 2000	200	214	03-6371-5680
		Tepco Town Planning Corporation Limited	Redevelopment and city planning, and consulting, design and building of underground facilities	August 2001	300	72	03-5925-0766
		The TEPCO Reinsurance Company PCC Limited	Exclusive reinsurance of TEPCO Group	October 2002	120	0	-
		TEPCO HUMMING WORK CO., LTD.	Printing, copying, cleaning, gardening service and others	July 2008	60	89	042-848-7300
		Toden Kokoku Co., Ltd.	Utility pole advertising, power distribution line blueprint revision and management, creation of PR plans	October 1931	20	537	03-6371-8111
		TEPCO CALL ADVANCE Inc.	Contract telephone response and related consulting services, telemarketing planning and sales	July 2003	150	1,610	03-6371-8330
		Tepco Partners Co., Inc.	Nursing-care insurance business and training related	January 2006	100	1,237	03-5621-7333
		ATEMA KOGEN RESORT INC.	Hotel and golf course management	February 1989	100	182	025-758-4888
		Houseplus Corporation, Inc.	Building performance evaluation and assurance	February 2008	907	105	03-5962-3800
		The Japan Utility Subway Company, Incorporated	Design, construction and management of common tunnel monitoring systems	January 1986	1,400	48	03-3663-7611
		Daido Industrial Arts Co., Ltd.	Creation of utility pole advertising products	October 1953	10	27	03-6372-6969
		Houseplus Architectural Inspection, Inc.	Confirmatory test pursuant to the Building Standard Law	November 1999	300	52	03-5962-3830

	Company Name	Description of Major Business	Date Established (month/year)	Capital (million yen)	Employees (including temporary workers)	Phone
Oversea Business	Tokyo Electric Power Company International B.V.	Investment in afforestation projects	July 1999	240,000 €1,000	0	-
	Tokyo Electric Power Company International Paiton I B.V.	Investment in IPP business company in Indonesia	May 2005	34 €1,000	0	-
	TM Energy (Australia) Pty. Ltd.	Power generation in Australia	February 2002	88,500 A\$1,000	0	-
	Tokyo Electric Power Company International Paiton II B.V.	Investment in IPP business company in Indonesia	May 2005	18 €1,000	-	-
	CIPI-GP Ltd.	Investment in IPP business company in Indonesia	January 1995	12 US\$1,000	-	-
	Capital Indonesia Power I C.V.	Investment in IPP business company in Indonesia	December 1994	-	-	-
	Eurus Energy Holdings Corporation	Supervision and management of wind energy projects, etc. in Japan and abroad	November 2001	18,199	185	03-5404-5300
	International Nuclear Energy Development of Japan Co., Ltd.	Planning and study of promotion activities for nuclear power projects in the emerging countries	October 2010	100	8	03-3504-0892
	TeaM Energy Corporation	IPP business in Phillippine	August 2007	12,162 US\$1,000	742	-
	TEPDIA Generating B.V.	Thailand IPP	February 2011	18 €1,000	0	-
	ITM Investment Company Limited	Investment in Umm Al Nar power generation and water desalination project	February 2003	16 US\$1,000	0	-
	Tas Forest Holdings Pty. Ltd.	Afforestation	October 1995	13,035 A\$1,000	0	-
	ITM O&M Company Limited	Operation and maintenance of power generation and desalination equipment at Umm Al Nar power generation and desalination project	February 2003	0 AED	338	-
	Star Buck Power Corporation	IPP business in Taiwan	August 2006	3.3 billion TWS	55	-

<Reference> Outline of TEPCO Gas Business

- Restrain investment in new facilities as much as possible, and develop business centered on factories and other users near existing LNG terminals and gas lines that can ensure profitability.
- Consignment sales through gas pipelines of Tokyo Gas Co., Ltd.
- LNG lorry selling in the area where the gas conducting pipe network is not developed (from Futttsu LNG base).

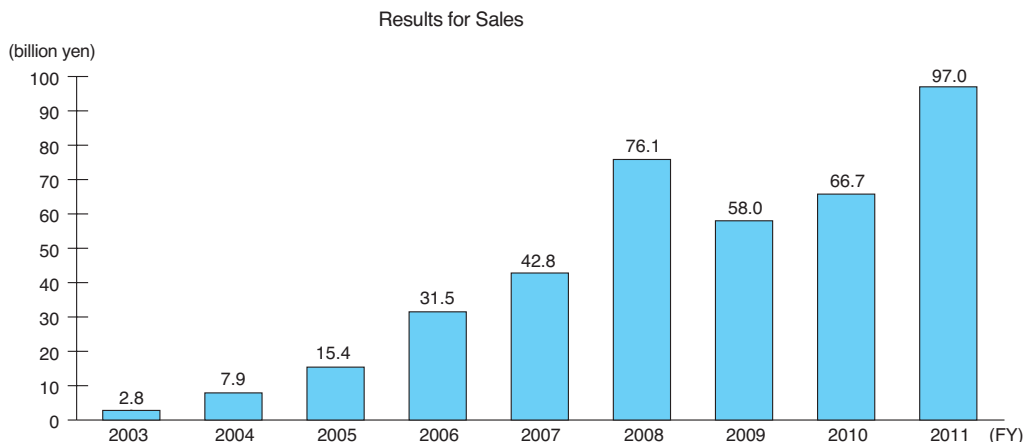

Customers marketing gas (as of April 2012)

[Direct distribution]

- Otaki Gas Co., Ltd.
- Keiyo Gas Corporation
- JX Nippon Oil & Energy Corporation
- Kanto Natural Gas Development Co., Ltd.

etc.

Number of contracts: 25
 Output under the contracts: approx. 1,070,000 tons/year
 (on the average-year basis)

[Distribution through consignment]

(Using the gas pipe of Tokyo Gas)

- Nippon Paper Creca Co., Ltd.
- Higashinihon Gas Corporation
- Nippon Gas Co., Ltd.

etc.

Number of contracts: 13
 Output under the contracts: approx. 30,000 tons/year
 (on the average-year basis)

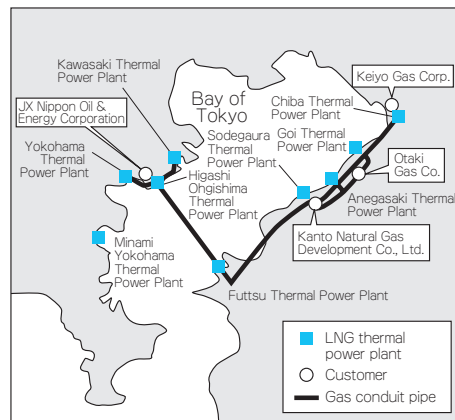

XV. Other Data

1. Energy Dependency of Major Countries (2009)

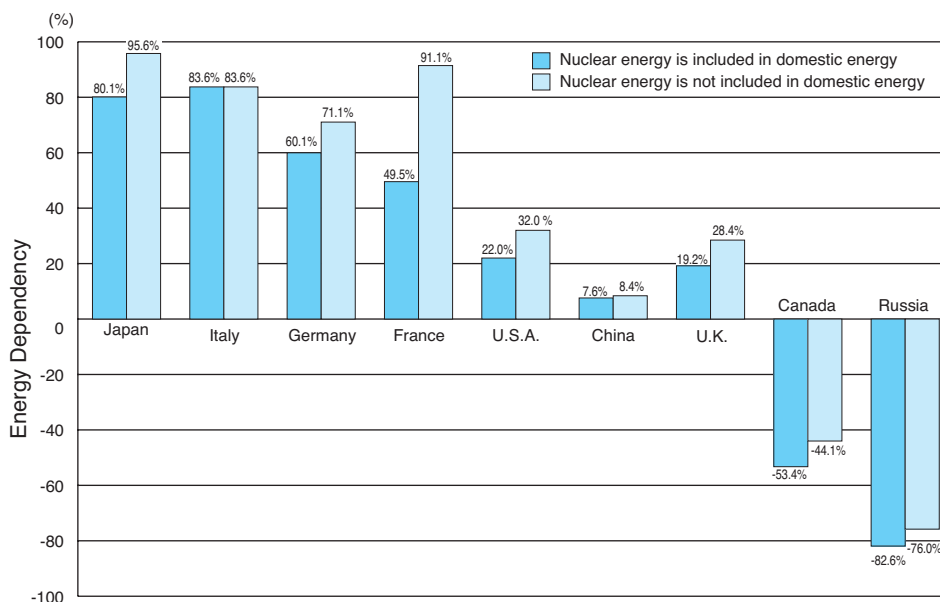

Note: Canada and Russia are net exporting countries.

Sources: "Energy Balances of OECD Countries 2011 edition," IEA.

"Energy Balances of Non-OECD Countries 2011 edition," IEA.

2. Composition of Primary Energy Sources in Major Countries (2009)

(%)

	Coal	Oil	Gas	Nuclear	Renewable Energy	Electricity Imports	Total
Japan	21.5	42.5	17.1	15.4	3.5	-	100.0
U.S.A.	22.4	37.0	24.7	10.0	5.7	0.1	100.0
United Kingdom	15.2	32.5	39.7	9.2	3.4	0.1	100.0
France	4.4	31.6	15.0	41.7	8.2	-0.9	100.0
Germany	22.5	33.0	24.0	11.0	9.8	-0.3	100.0
Italy	7.7	40.9	38.8	-	10.2	2.3	100.0
Canada	9.4	34.6	31.0	9.3	17.0	-1.1	100.0

Notes: 1. Minus mark in electricity imports column indicates exports.

2. Total may not work out to be 100 because of rounding off.

3. Renewable energy includes geothermal, photovoltaic, hydro, and wind energy sources, etc.

Source: "Energy Balances of OECD Countries 2011 edition," IEA.

<Reference> Japan's Energy Self-Sufficiency Rate (2009)

(%)

	FY	1973	1987	1988	1989	1990	1991	1992	1993	1994	1995	1996	1997
Energy Self-Sufficiency Rate	(lowest)	9.2	19.3	17.5	17.1	17.1	17.8	17.6	19.2	18.7	19.9	20.1	20.7
	FY	1998	1999	2000	2001	2002	2003	2004	2005	2006	2007	2008	2009
Energy Self-Sufficiency Rate		21.7	20.4	20.4	20.5	19.0	16.6	18.2	19.3	19.5	17.6	17.9	19.9

Note: The numbers above are the self-sufficiency ratio on the assumption that uranium is domestic energy.

$$\text{Self-sufficiency rate (\%)} = \frac{\text{Domestic energy}}{\text{Domestic energy} + \text{Imported energy}} \times 100$$

Source: "Energy Balances of OECD Countries 2011 edition," IEA.

<Reference> Self-Sufficiency Rate by Energy Source in Japan (2009)

(%)

Coal	Oil	Natural Gas	Nuclear	Hydro, Geothermal, New Energy and Others
0	0.4	4.3	100	100

<Reference> Import and Export of Electricity Related to France (2009)

(GWh)

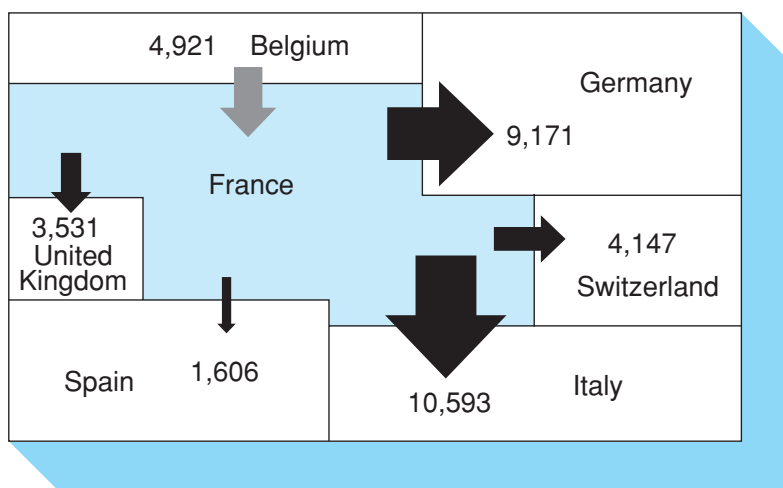

Note: Number data above reflects balance of electricity import and export between France and each country.

Source: "Overseas Electric Power Industry statistics 2011," Japan Electric Power Information Center, Inc.

3. Security Index of Various Countries (2009)

	Dependent Ratio Imported Energy (%)	Dependent Ratio Oil Energy (%)	Dependent Ratio Imported Oil (%)	Dependent Ratio Imported Crude Oil from Hormuz (%)	Oil Consumption (M ton)
Japan	80.1	42.5	99.6	82.7	201.4
U.S.A.	22.0	37.0	57.9	11.9	833.6
United Kingdom	19.2	32.5	-11.0	0.4	71.6
Germany	60.1	33.0	96.3	2.5	111.5
France	49.5	31.6	98.6	12.2	82.9
Canada	-53.4	34.6	-77.8	9.1	103.1
Italy	83.6	40.9	92.7	12.3	71.1
Sweden	33.2	26.1	100.0	0.0	14.5
India	25.7	31.2	75.8	-	162.3
China	7.6	18.5	50.0	-	461.8
Russia	-82.6	21.5	-257.9	-	136.0

- Notes:
1. Minus mark indicates exports.
 2. The figures in the "Dependent ratio imported crude oil from Hormuz" column are figures for imports from Saudi Arabia, Iran, Qatar, Kuwait, UAE, Bahrain and the neutral zone.
 3. OPEC countries include Saudi Arabia, Iran, Qatar, Kuwait, UAE, Iraq, Ecuador, Algeria, Angola, Nigeria, Venezuela, Libya, and the neutral zone. (The Ecuador's membership right was suspended at OPEC's general assembly in 1992, and Ecuador regained its membership in 2007.) (Gabon joined the Organization in 1975, and the withdrawal from OPEC was approved at OPEC's general assembly in 1996.) (Indonesia temporarily withdraw from OPEC in 2009.)
 4. The figures in the "Dependent ratio imported crude oil from Hormuz" column do not match the figures shown in the next table due to different statistics of resources.
 5. The figures in the "oil consumption" column are the amounts of oil consumed in FY2011.

Sources: "Energy Balances of OECD Countries 2011 edition," IEA.

"Energy Balances of NON-OECD Countries 2011 edition," IEA.

"Oil, Gas, Coal and Electricity 4Q 2011," IEA.

"BP Statistical Review of World Energy 2012," BP.

4. Changes in Japan's Crude Oil Imports and Security Index

FY	1973	1979	1985	1990	1995	2000	2005	2006	2007	2008	2009	2010	2011
Crude Oil Imports (million kl)	288.61 (16.9)	277.14 (2.6)	197.26 (-7.4)	238.48 (-13.1)	265.53 (-3.0)	254.60 (2.4)	249.01 (3.0)	238.65 (-4.2)	242.03 (1.4)	234.41 (-3.1)	211.66 (-9.7)	214.36 (1.3)	209.17 (-2.4)
Dependent Ratio Crude Oil from Middle East (%)	77.5	75.9	68.8	71.5	78.6	87.1	89.1	88.9	86.4	87.8	89.5	86.6	85.1
Dependent Ratio Crude Oil from OPEC (%)	92.9	87.5	71.6	78.0	79.9	87.6	90.0	90.3	87.7	88.2	86.2	84.0	83.5
Dependent Ratio Crude Oil from Hormuz (%)	75.3	66.3	56.7	63.0	71.4	81.1	85.4	86.0	83.1	84.0	83.5	80.3	80.5

- Notes:
1. Figures in parentheses for crude oil imports represent the rate of increase against previous year.
 2. The figures in the "Dependent ratio imported crude oil from Hormuz" column are figures for imports from Saudi Arabia, Iran, Qatar, Kuwait, UAE, Bahrain and the neutral zone.
 3. OPEC countries include Saudi Arabia, Iran, Qatar, Kuwait, UAE, Iraq, Ecuador, Algeria, Angola, Nigeria, Venezuela, Libya, and the neutral zone. (The Ecuador's membership right was suspended at OPEC's general assembly in 1992, and Ecuador regained its membership in 2007.) (Gabon joined the Organization in 1975, and the withdrawal from OPEC was approved at OPEC's general assembly in 1996.) (Indonesia temporarily withdraw from OPEC in 2009.)

Source: "Yearbook of Metal Resources and Petroleum Products Statistics" (Yearbook 2011)

5. Power Generation Cost per Power Source

In December 2011, the "Cost Verification Committee" affiliated with the Energy and Environment Council announced the results of calculating power generation costs per power source.

The provisional calculations were implemented with a "model plant method*." Renewable energy sources, such as wind and photovoltaic (PV) power, are covered along with nuclear power, thermal power and hydropower. The social costs (e.g. accident-related costs, CO₂ abatement costs, policy expenses) were newly included.

Power generation will continuously be verified based on updated information.

* A model plant is assumed for each power source by referring to data obtained from existing modernized plants. The power generation cost per 1kWh is calculated by assuming construction costs, operations and maintenance costs, and the discount rate, etc.

[Results of Calculating Power Generation Cost per Power Source (December 2011)]

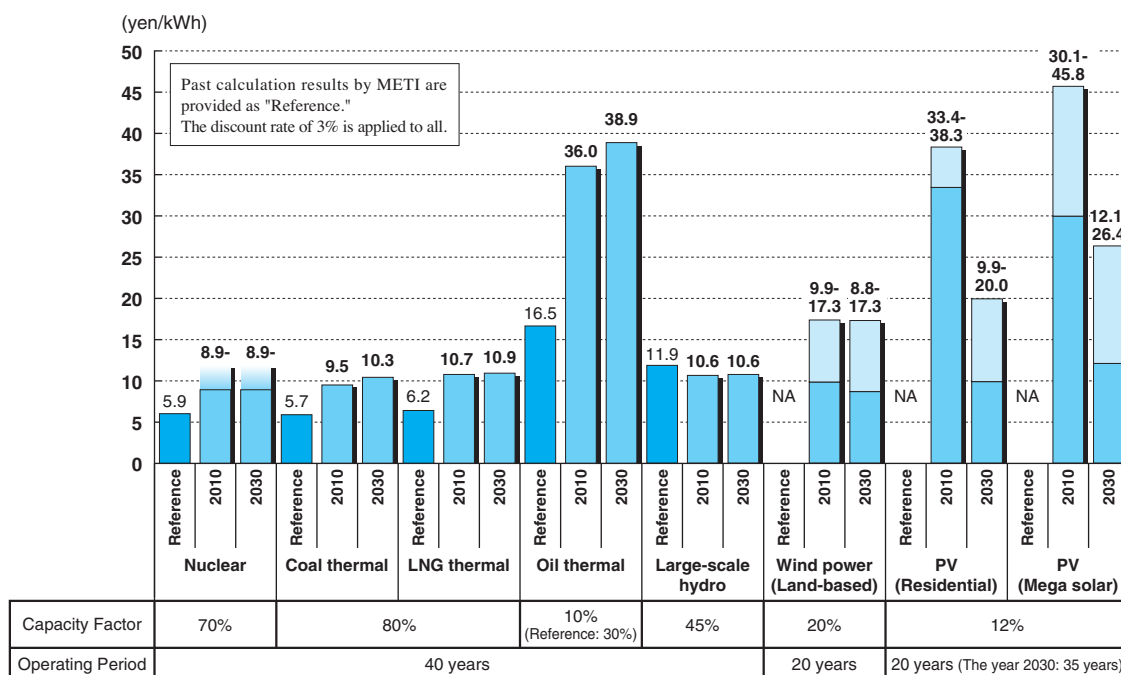

- Notes:
1. The calculation results are provisional and are subject to change based on new information. (As for nuclear power, power generation costs have been modified to "9.0-(yen/kWh)" according to government documentation issued on July 2012.)
 2. For nuclear power, policy expenses (e.g. R&D costs, construction promotion grants etc.) are added to the power generation costs. The settlement of Fukushima Daiichi Accident Costs, which are a key element of the accident-related costs described above, is still pending.
 3. There is a wide range of calculation results for wind and photovoltaic (PV) due to factors such as the following: establishing construction costs varies from the uppermost to the lowermost limits, technological innovations and the setting up of multiple scenarios with regards to volume efficiency. Costs for securing the grid stabilization in preparation for a rapid and huge introduction of renewable energy sources (e.g. installation of batteries) and policy expenses for dissemination of those sources are not included.

Source: "Cost Verification Committee Report (December 2011)," National Policy Unit.

MEMO

“TEPCO ILLUSTRATED” is an English translation of the Japanese original.

If there are any discrepancies between the translation and the original, the latter shall prevail.

TOKYO ELECTRIC POWER COMPANY
CORPORATE COMMUNICATIONS DEPARTMENT
1-1-3 UCHISAIWAI-CHO, CHIYODA-KU,
TOKYO 100-8560 JAPAN
PHONE: +81-3-6373-1111

TEPCO'S Website :

<http://www.tepco.co.jp/en/index-e.html>

