

# Outline of Water Treatment Facility System (Highly Concentrated Accumulated Water)

June 27, 2011

Tokyo Electric Power Company

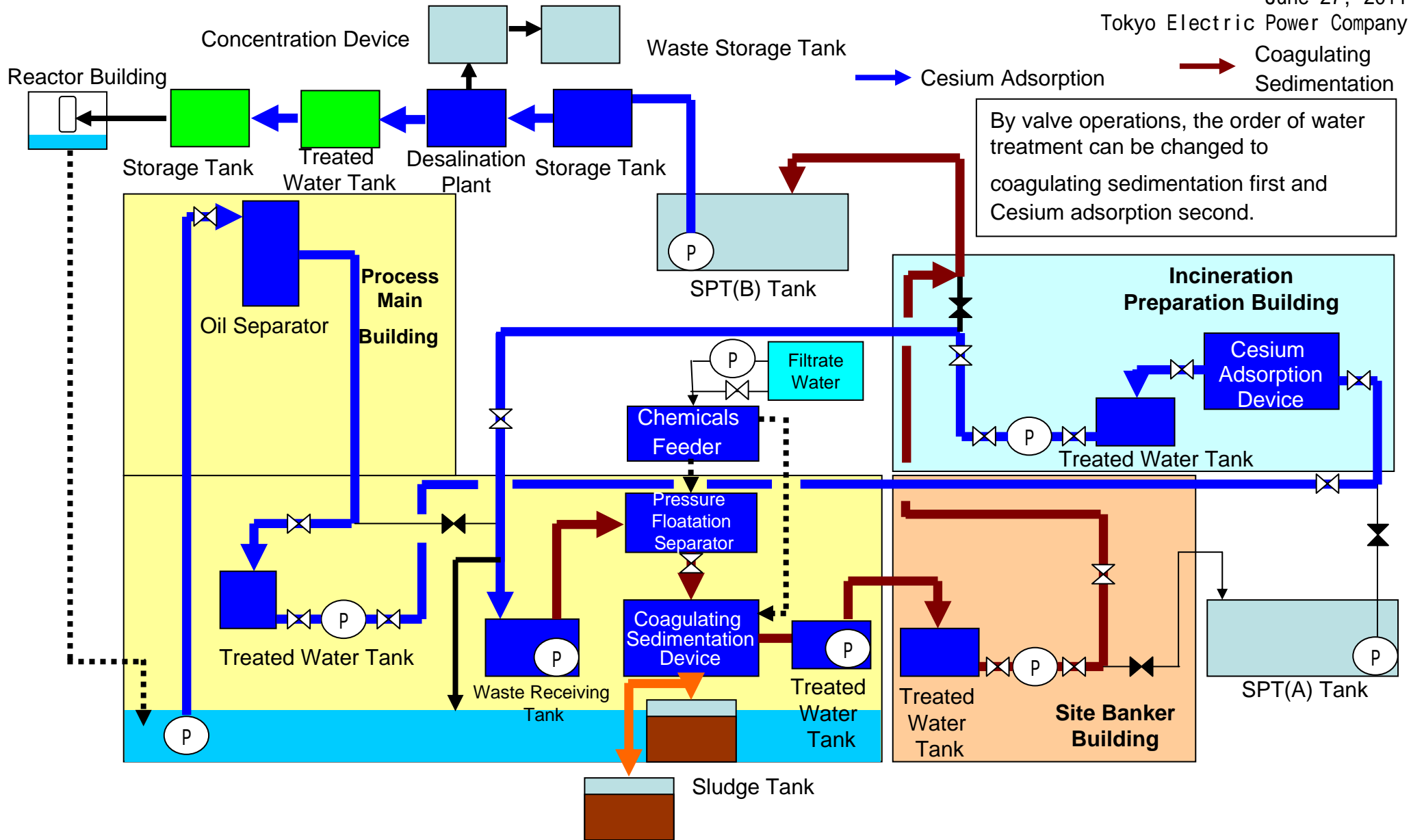

Water Flow: Process Main Building → Oil Separator → Cesium Adsorption Device → Coagulating Sedimentation → Desalination Plant

# Water Flow of Overall Water Treatment Facility

June 27, 2011  
Tokyo Electric Power Company

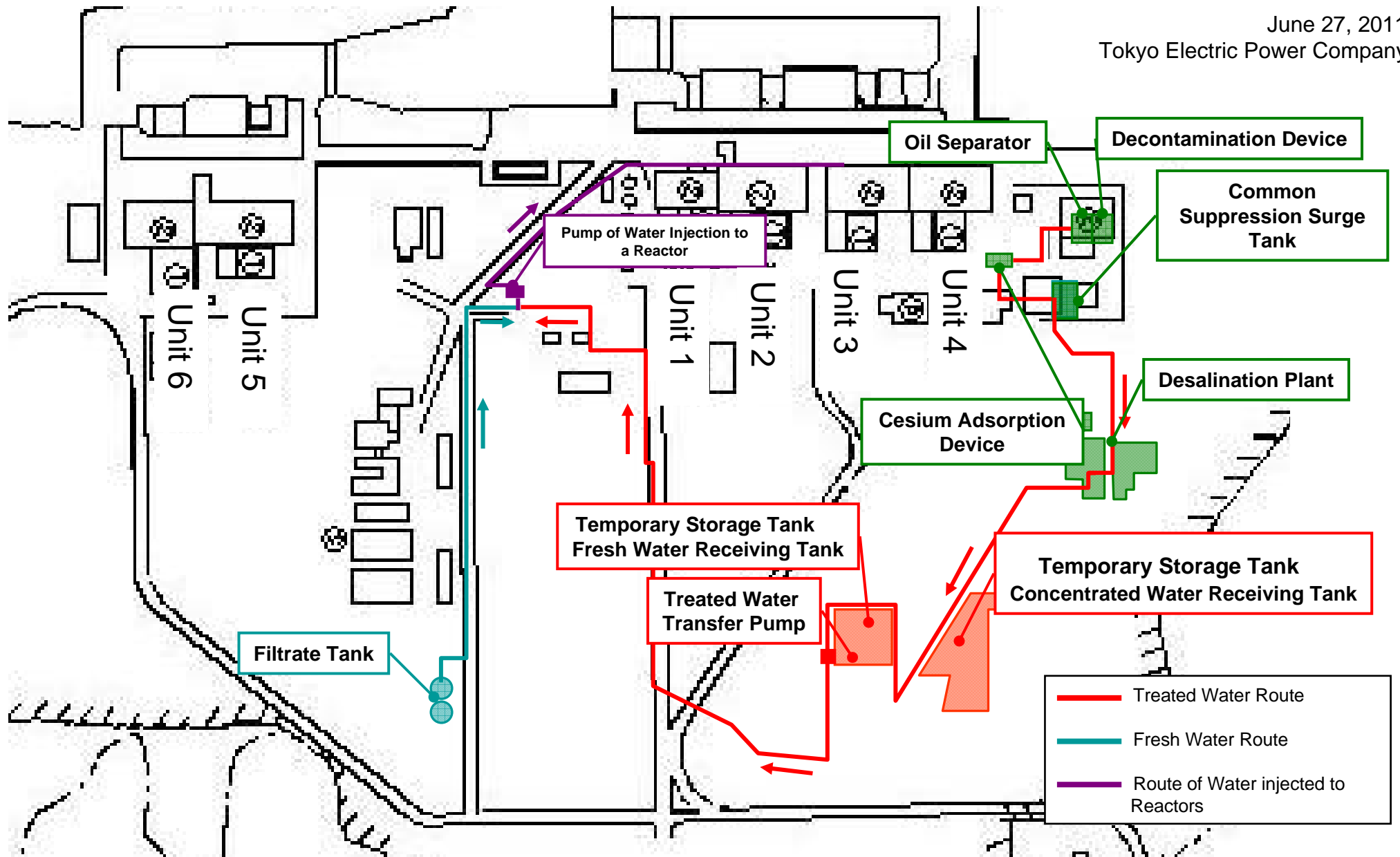

# Outline of Circulation and Injection System of Cooling Water (at Inception)

June 27, 2011

Tokyo Electric Power Company

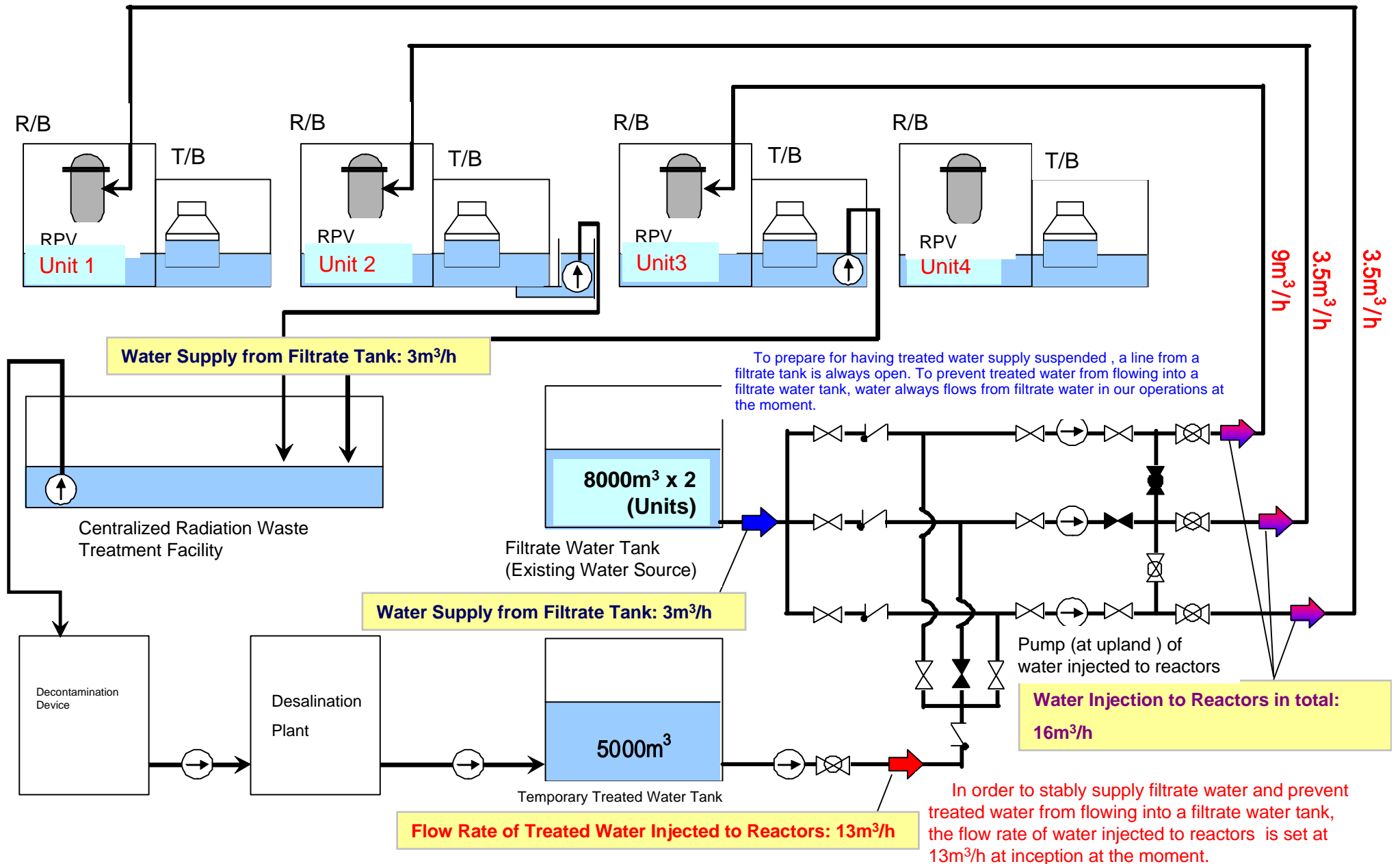

# Overall Image of Circulation and Injection of Cooling Water

June 27, 2011  
Tokyo Electric Power Company

