

---

<Reference material>  
December 3, 2011  
Tokyo Electric Power Company

# **Air dose rates in the buildings**

# Data collection period (1/2)

- Unit 1: April - November (11/23), 2011
- Unit 2: April - November (11/16), 2011
- Unit 3: April (4/25) - November (11/22), 2011
- Unit 4: April (3/31) - November (11/21), 2011
- Unit 5: March (3/30) - November (11/16), 2011
- Unit 6: March (3/30) - October (10/28), 2011

# Data collection period (2/2)

- Process main building (PM): April - October(10/27), 2011
- Incineration workshop building (MSW): May - November (11/10), 2011
- Miscellaneous solid waste volume reduction treatment building (HTI):  
April - November (11/10), 2011
- Side bunker building (SB): May - November (11/14), 2011
- Suppression pool water surge-tank building (SPT):  
May - November (11/14), 2011
- Operation support common facility: August - November (11/18), 2011

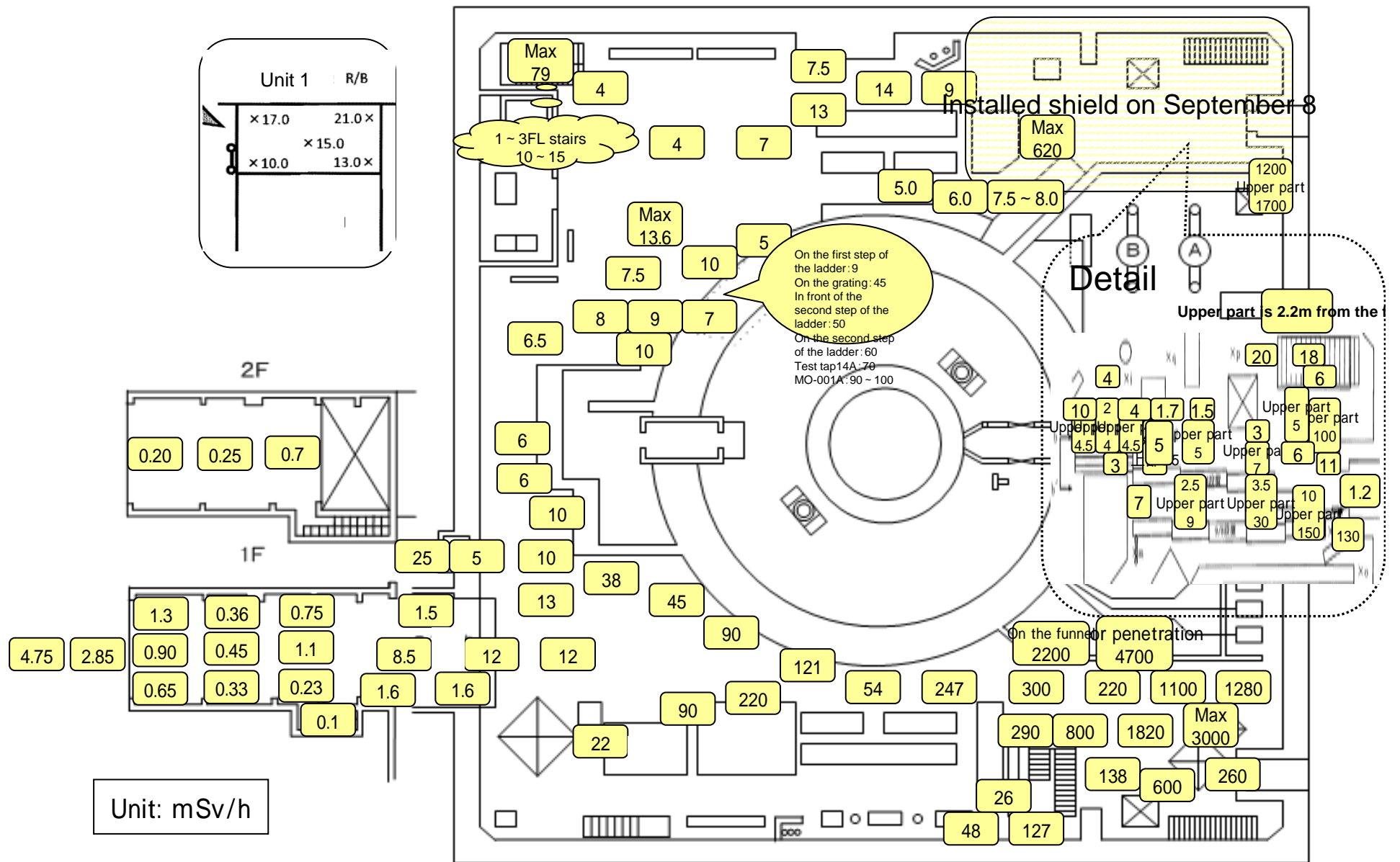

1FL, R/B, Unit 1

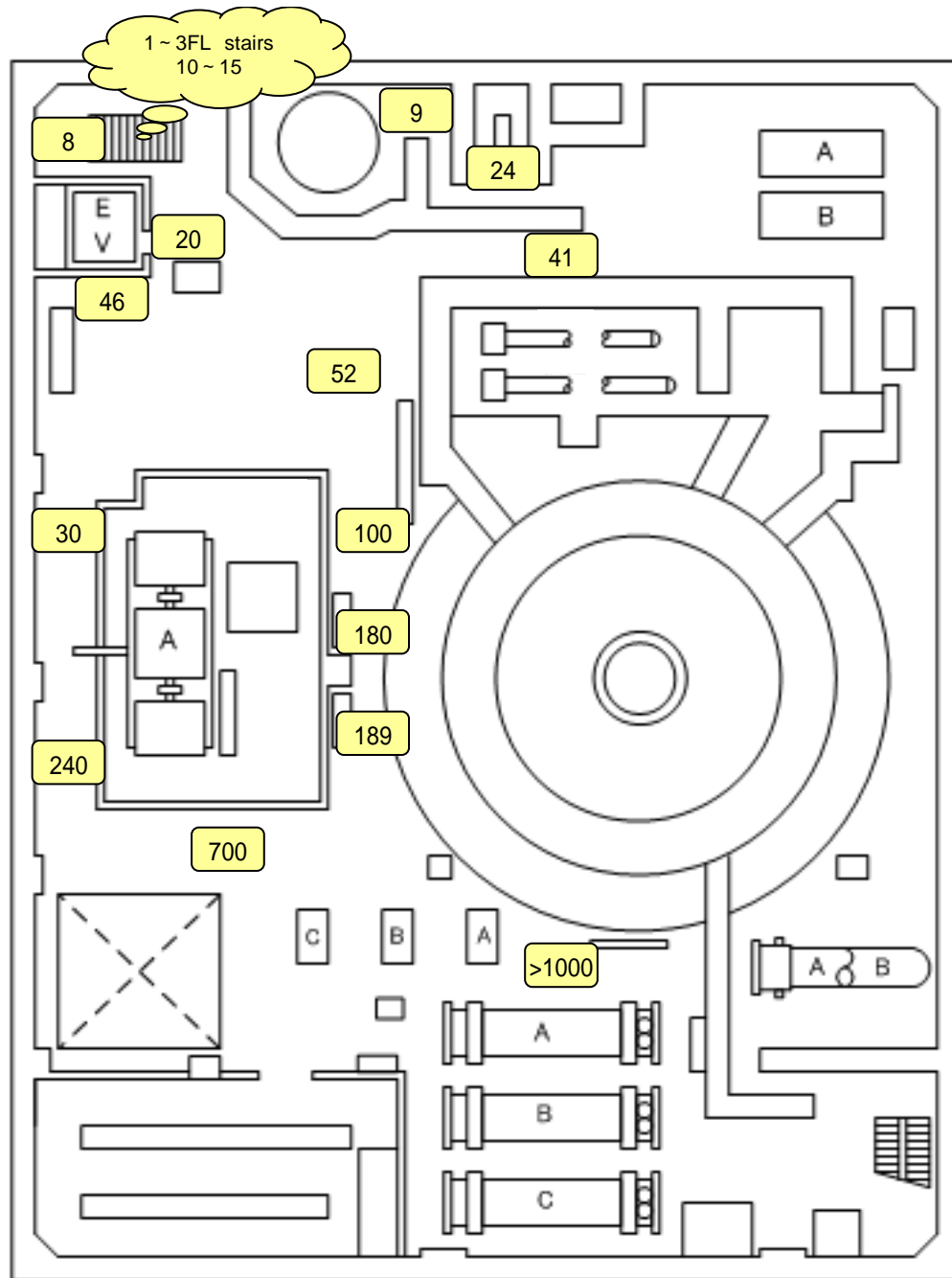

2FL, R/B, Unit 1

Unit: mSv/h

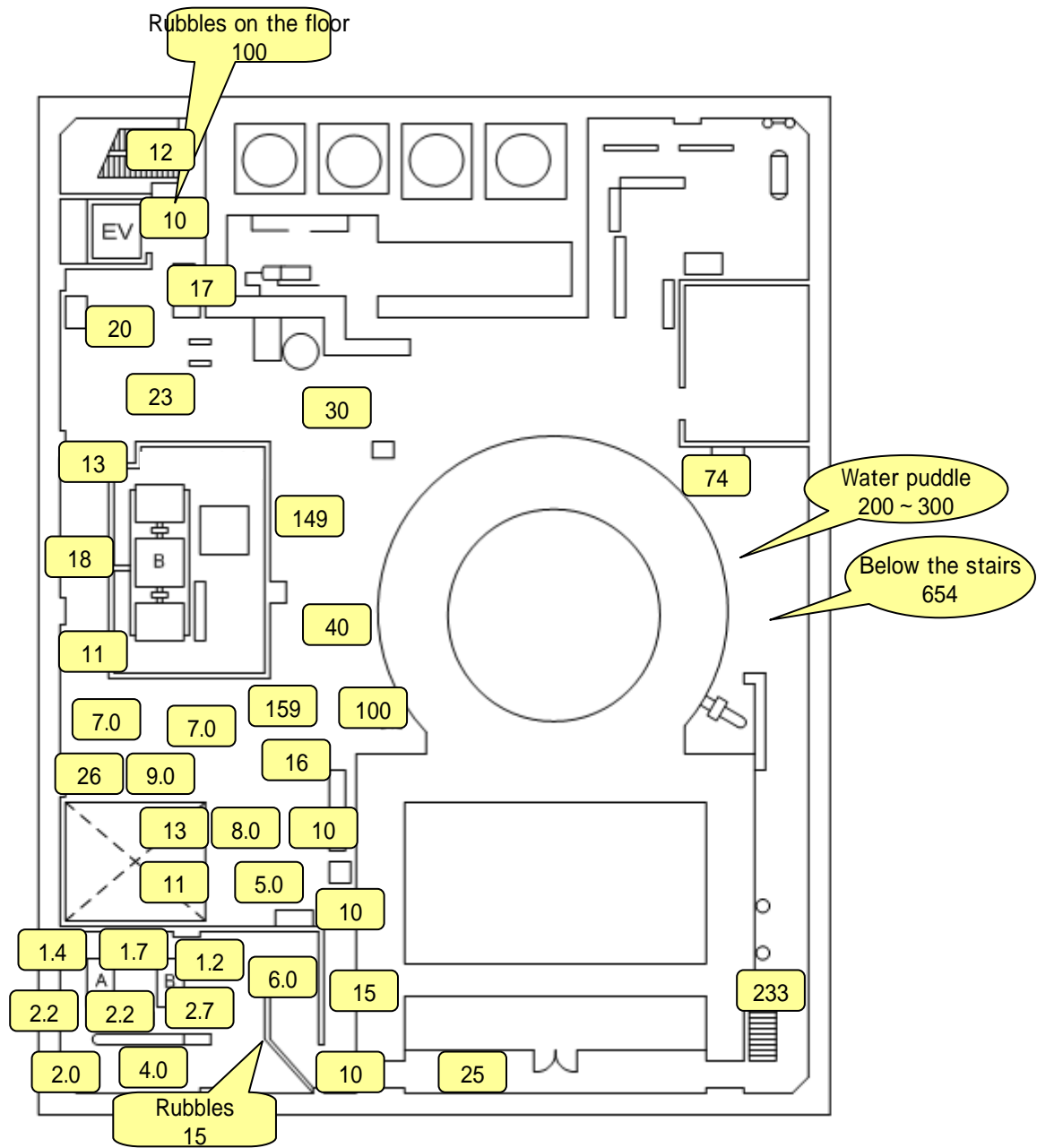

3FL, R/B, Unit 1

Unit: mSv/h

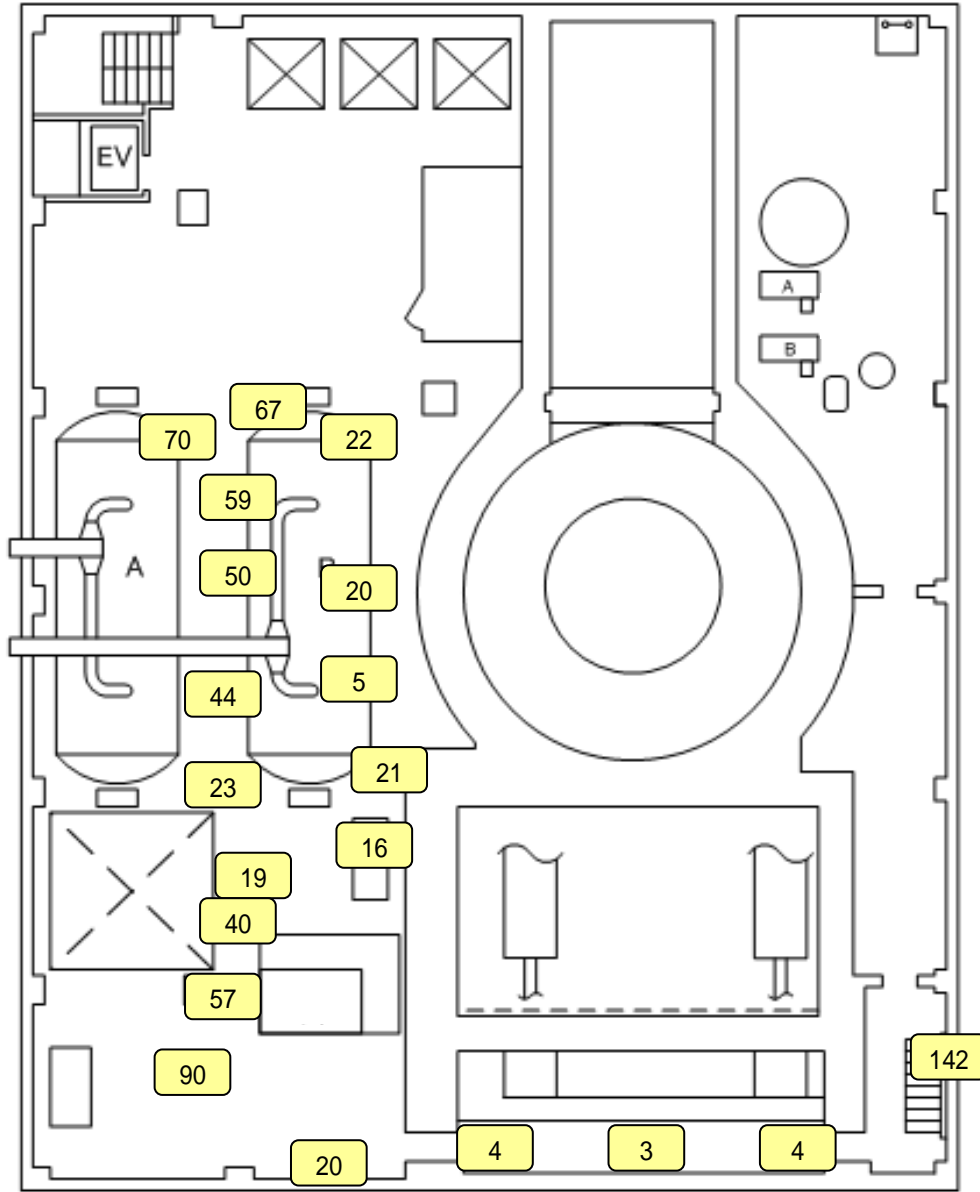

4FL, R/B, Unit 1

Unit: mSv/h

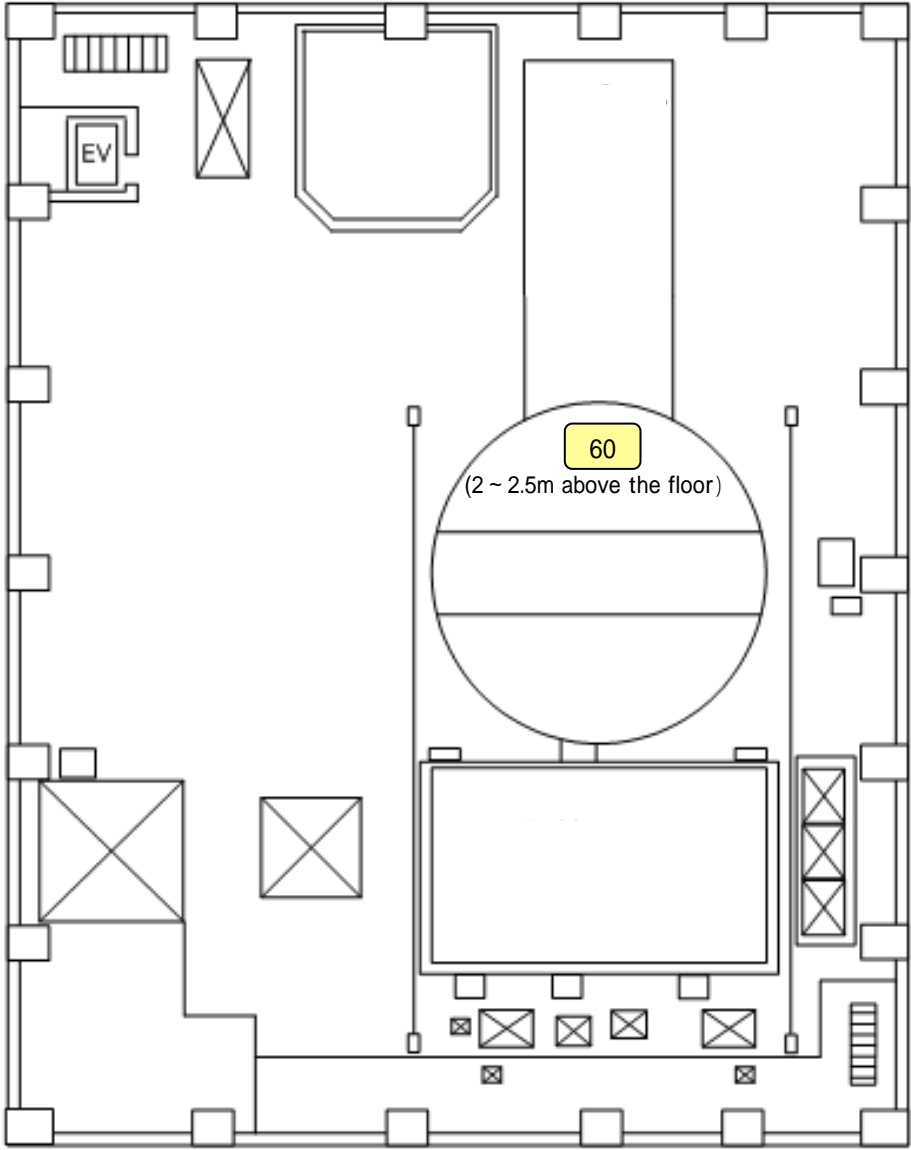

5FL, R/B, Unit 1



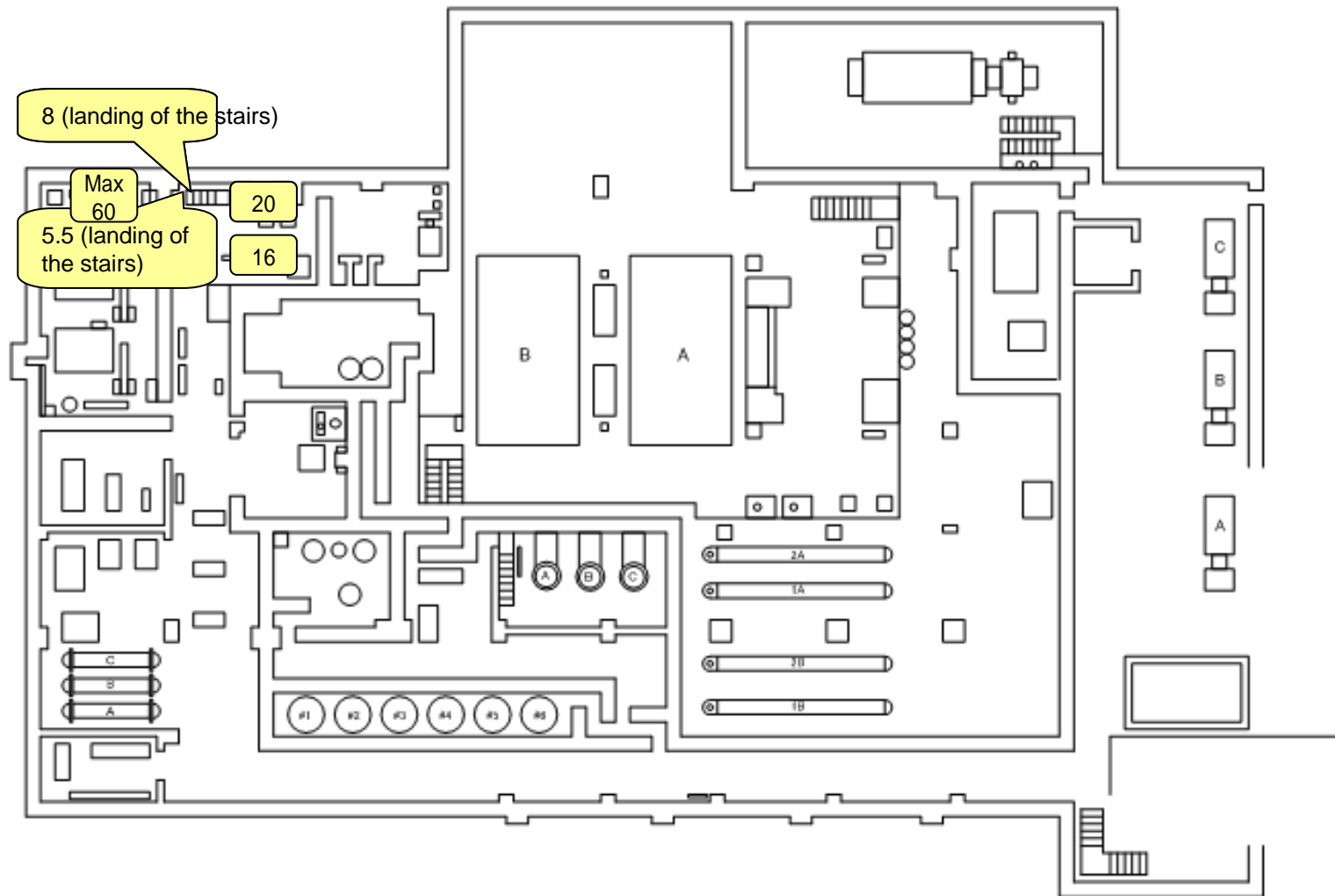

B1, T/B, Unit 1

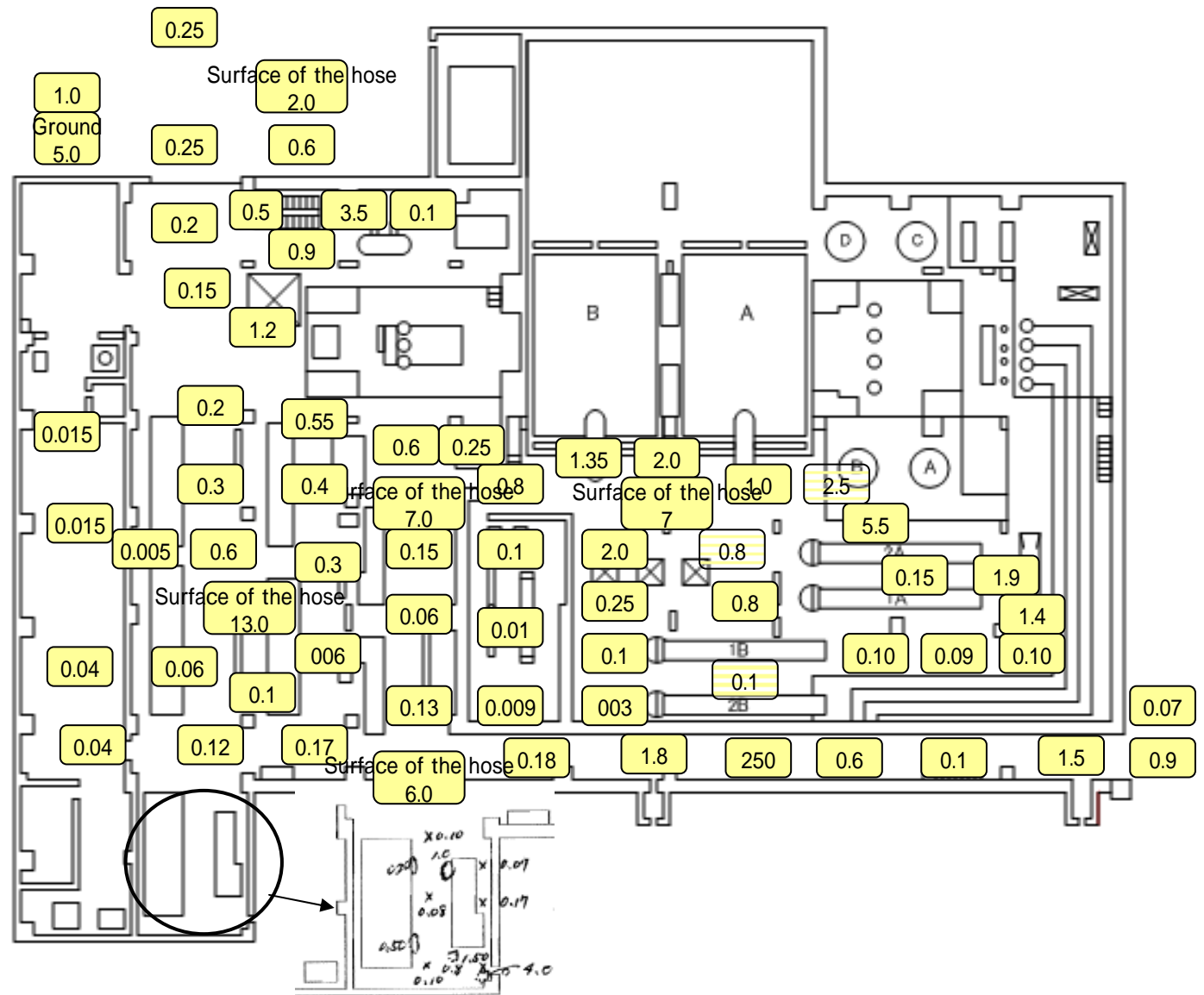

1FL, T/B, Unit 1

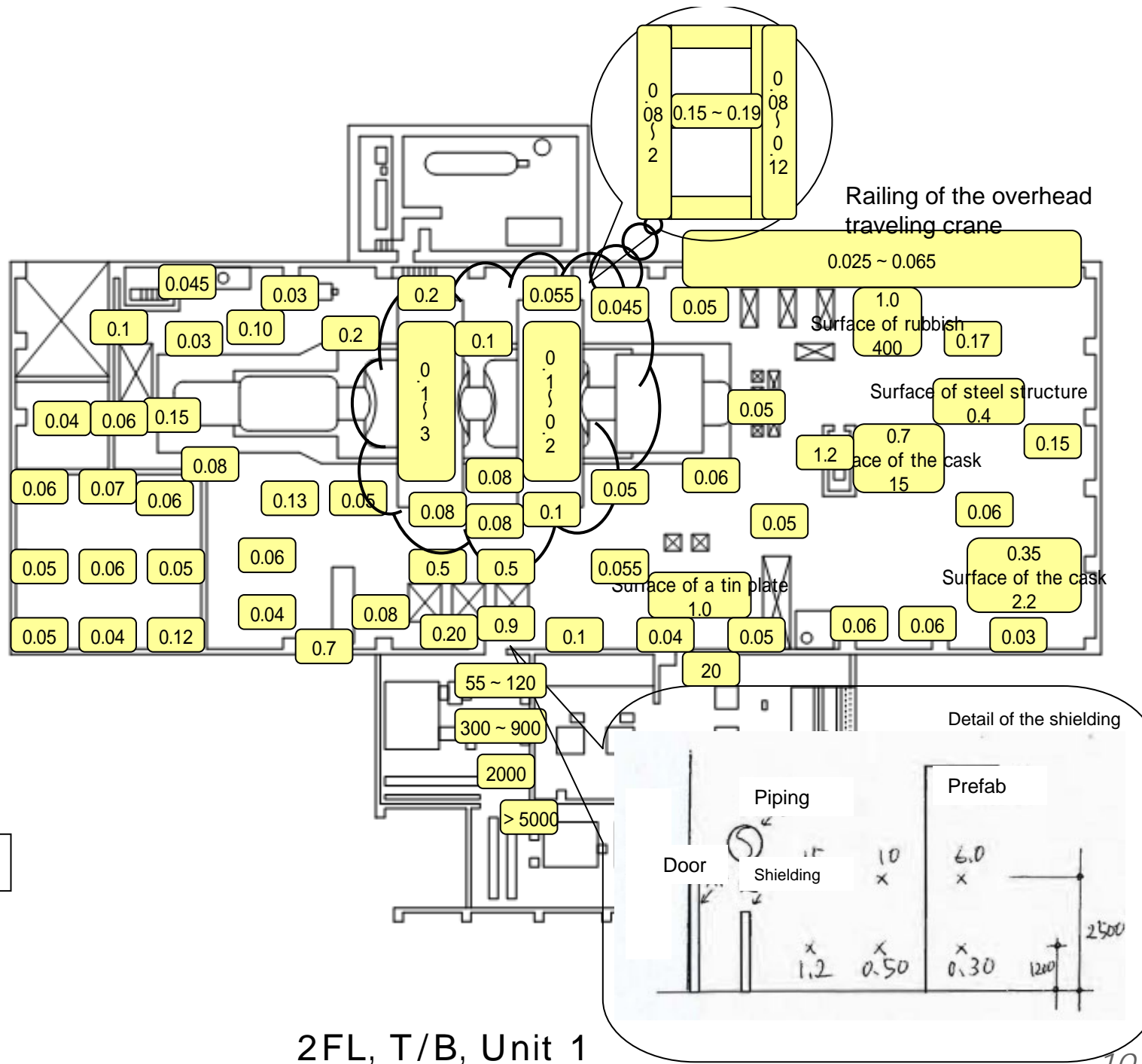

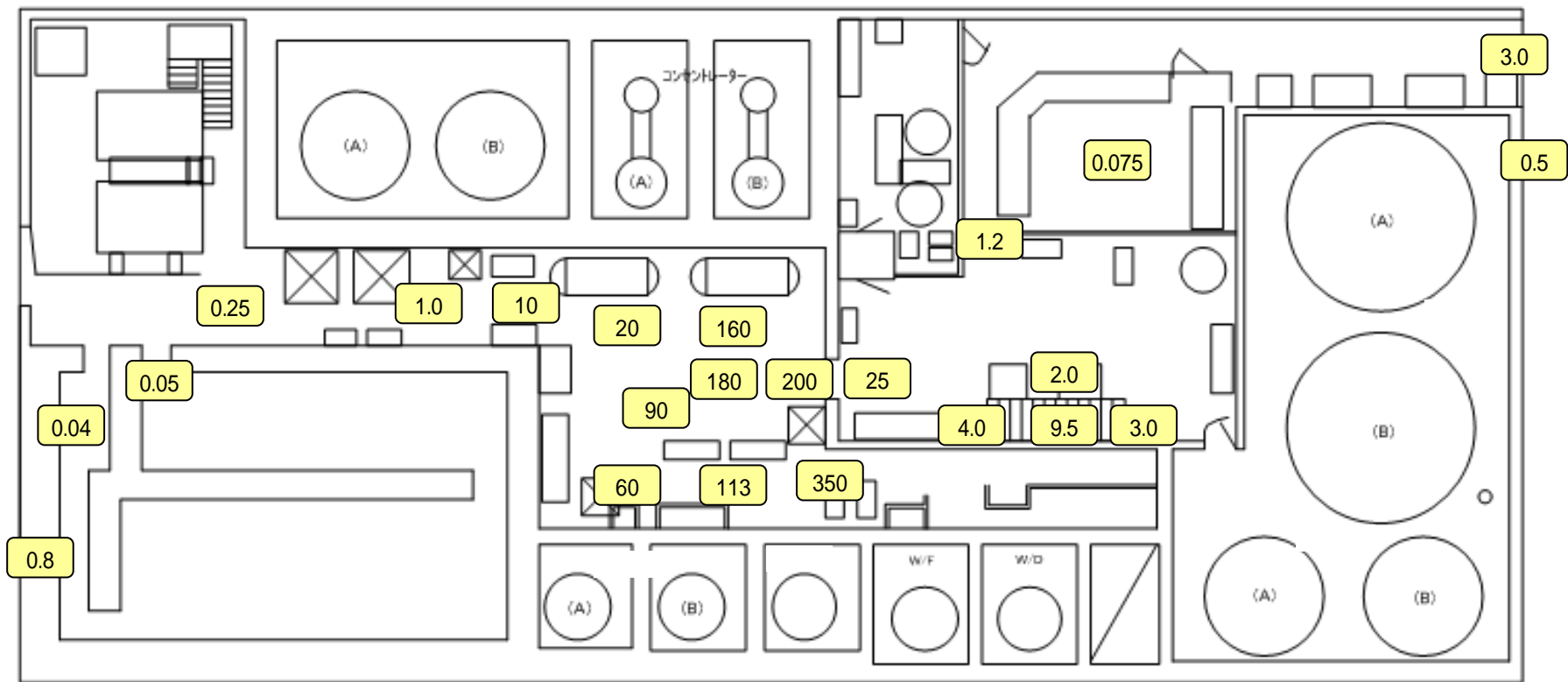

Unit: mSv/h

1FL, Rad Waste Treatment Bldg, Unit 1

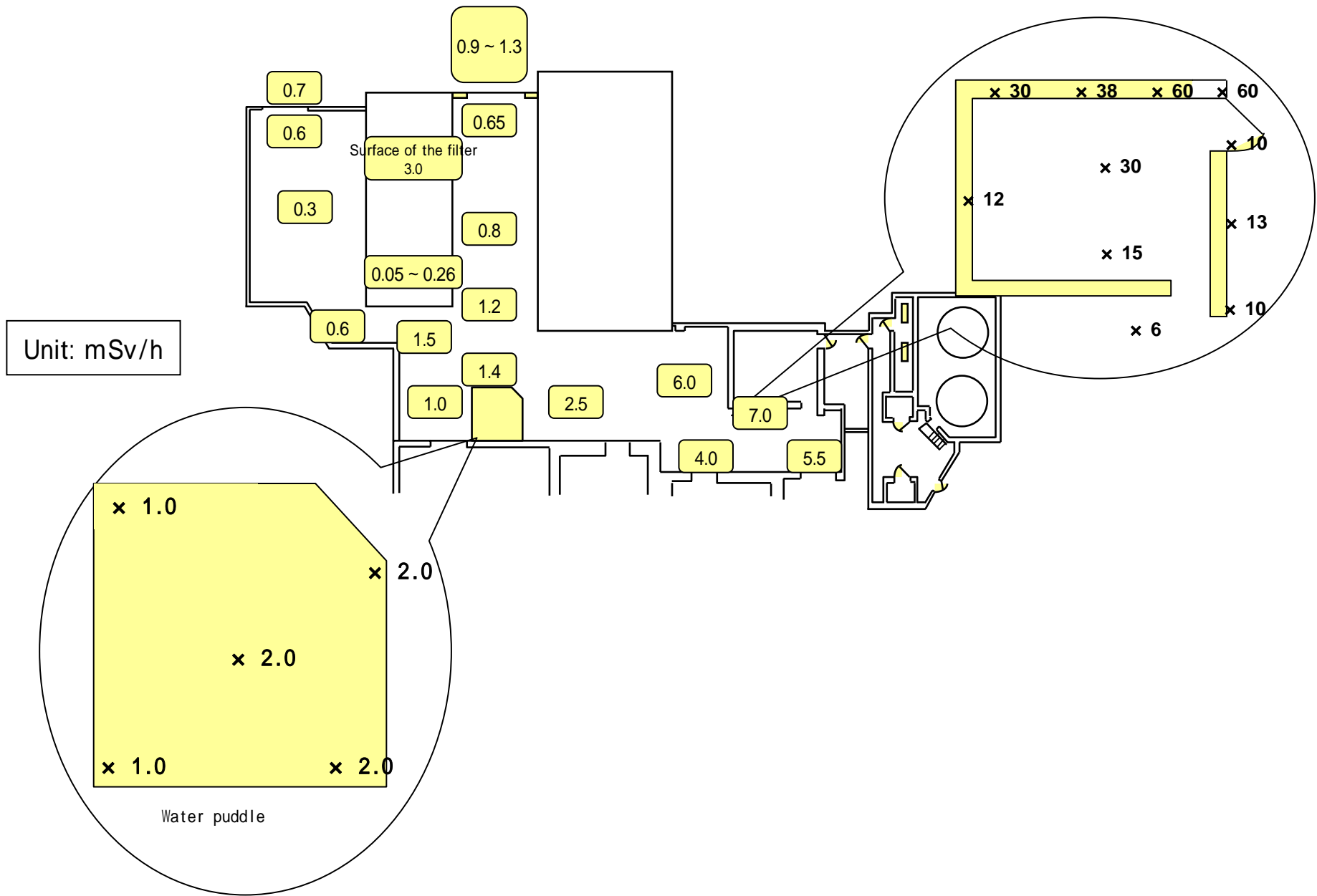

Oil drum carry out gate, Rad Waste Treatment  
Bldg, Unit 1

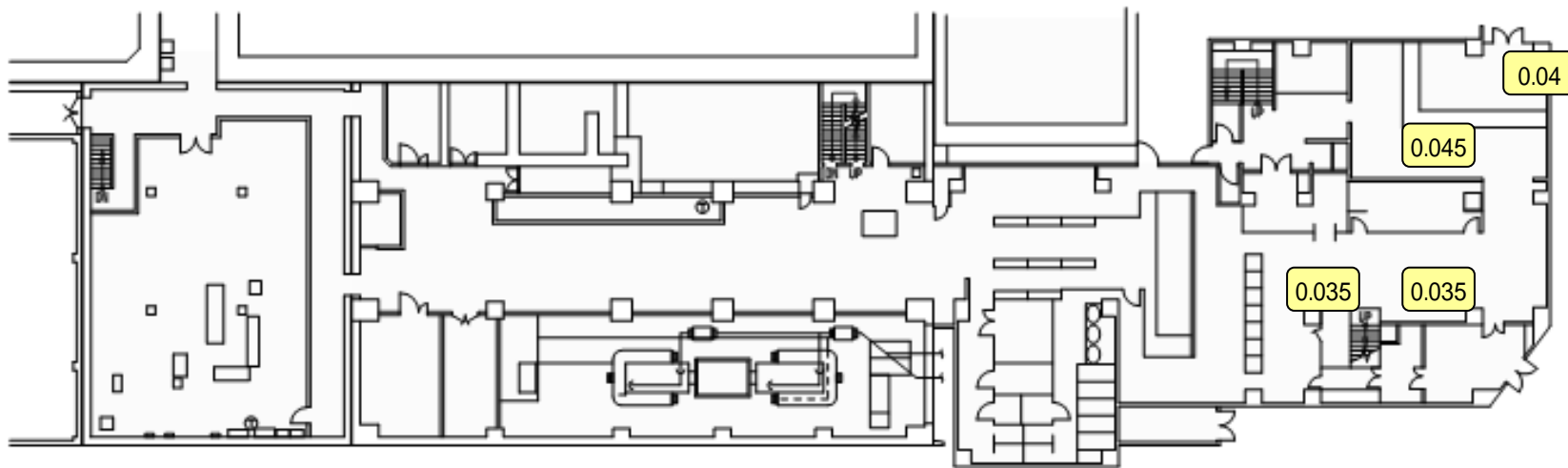

Unit: mSv/h

1FL, Service Bldg, Units 1 & 2

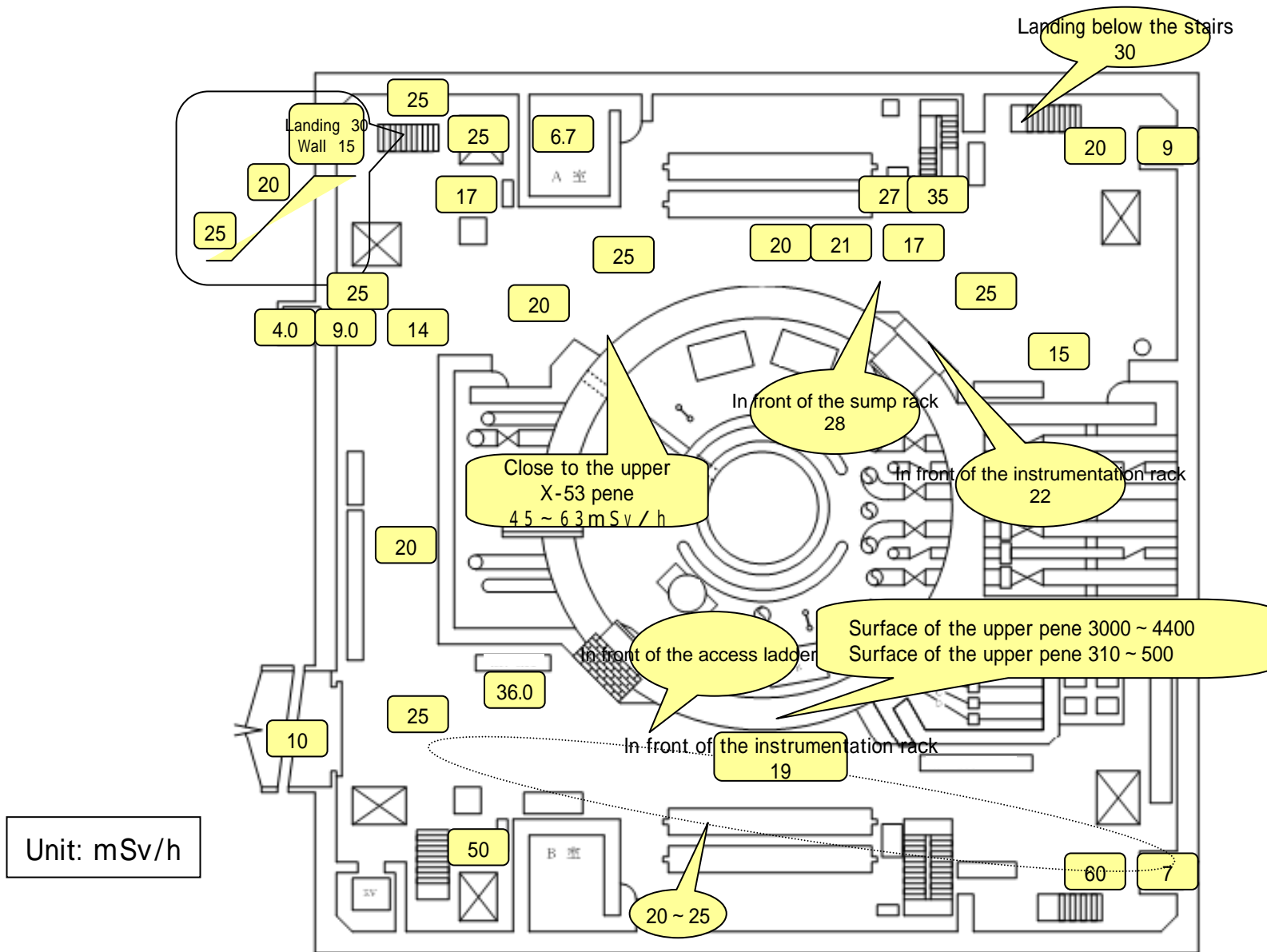

1FL, R/B, Unit 2

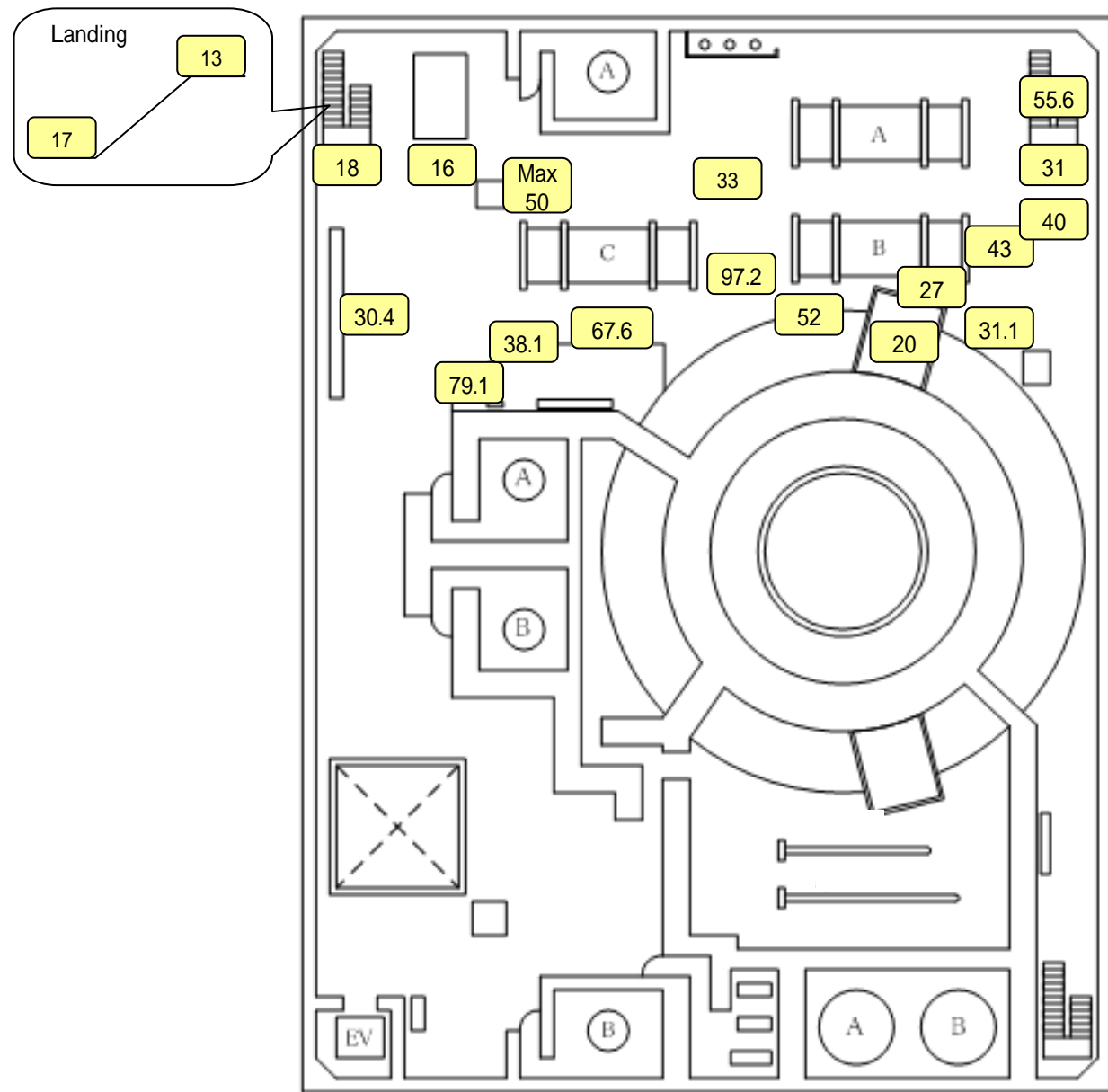

Unit: mSv/h

2FL, R/B, Unit 2



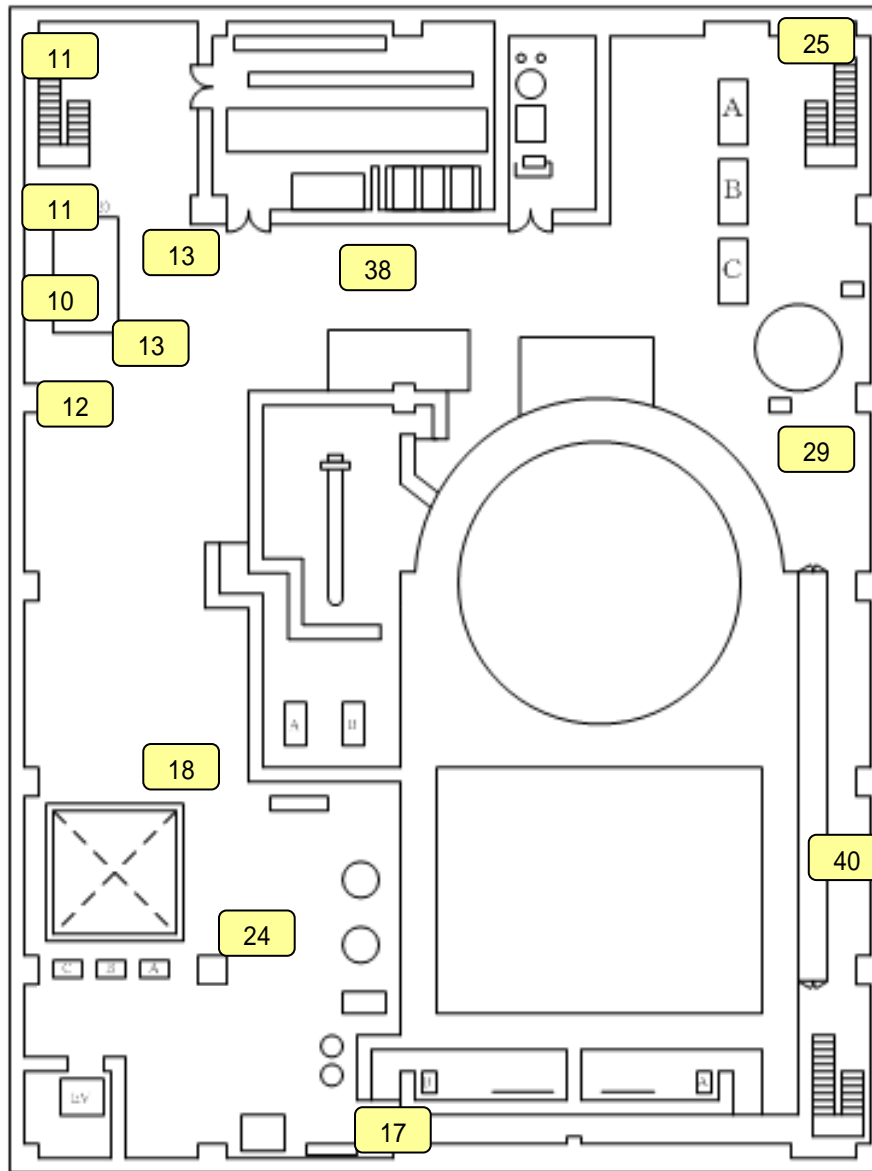

Unit: mSv/h

3FL, R/B, Unit 2

Unit: mSv/h

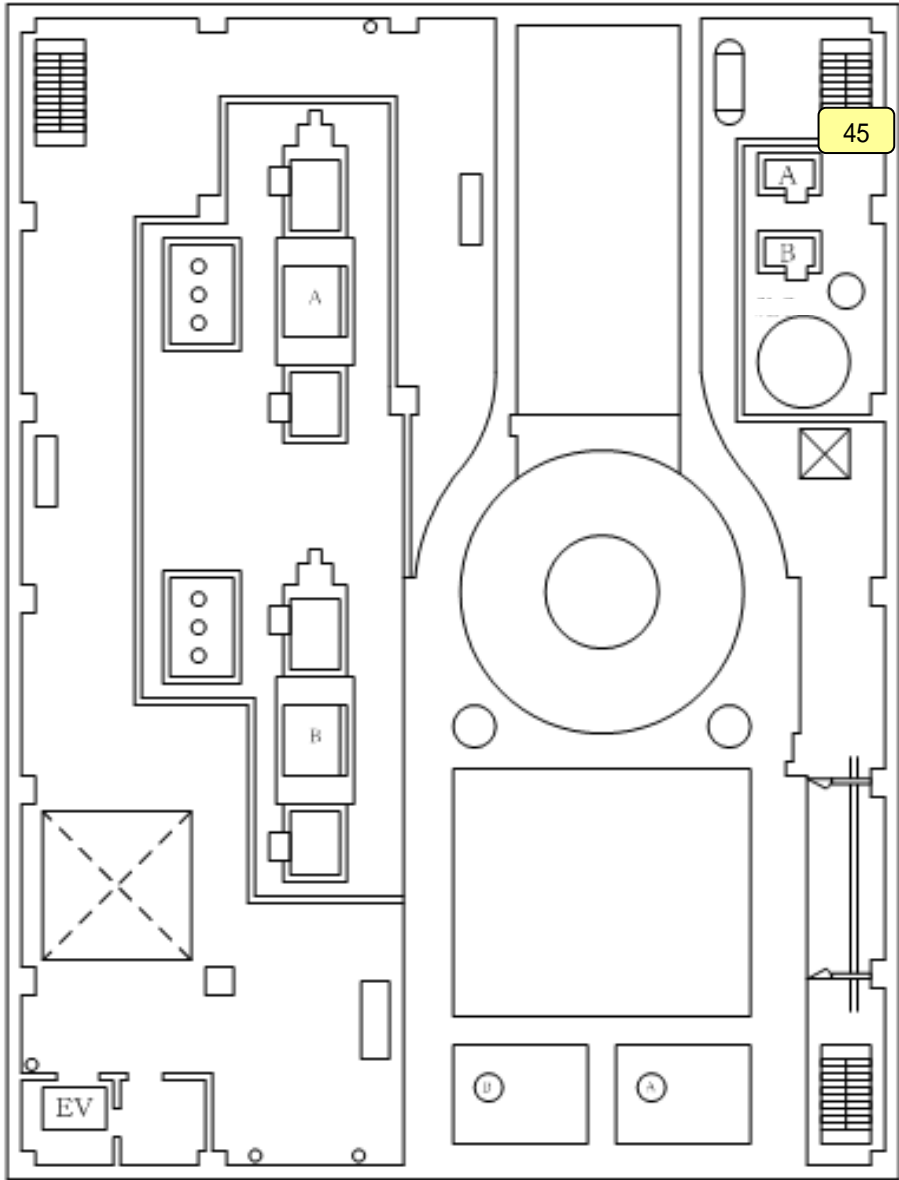

4FL, R/B, Unit 2

Unit: mSv/h

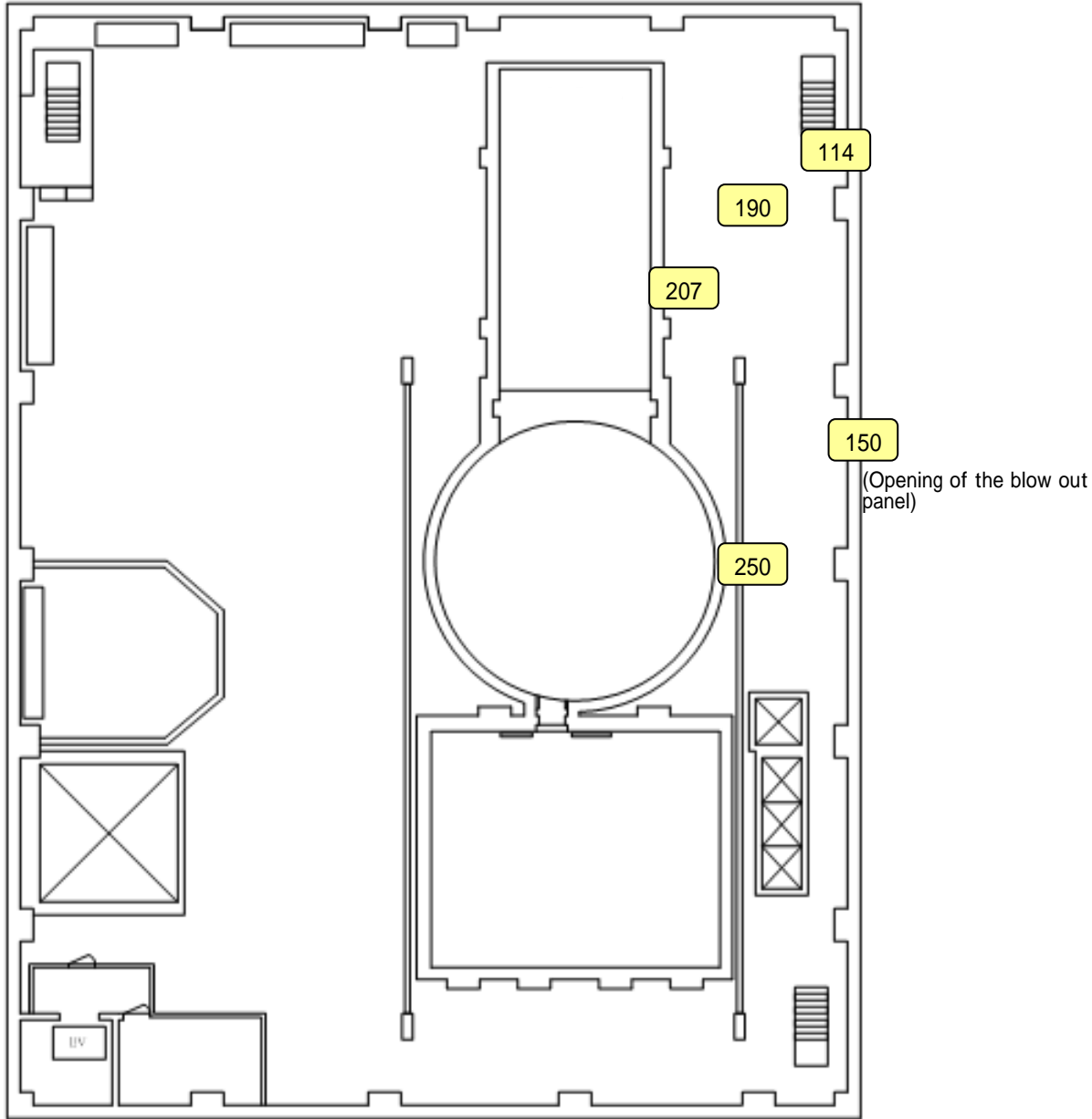

5FL, R/B, Unit 2

Unit: mSv/h

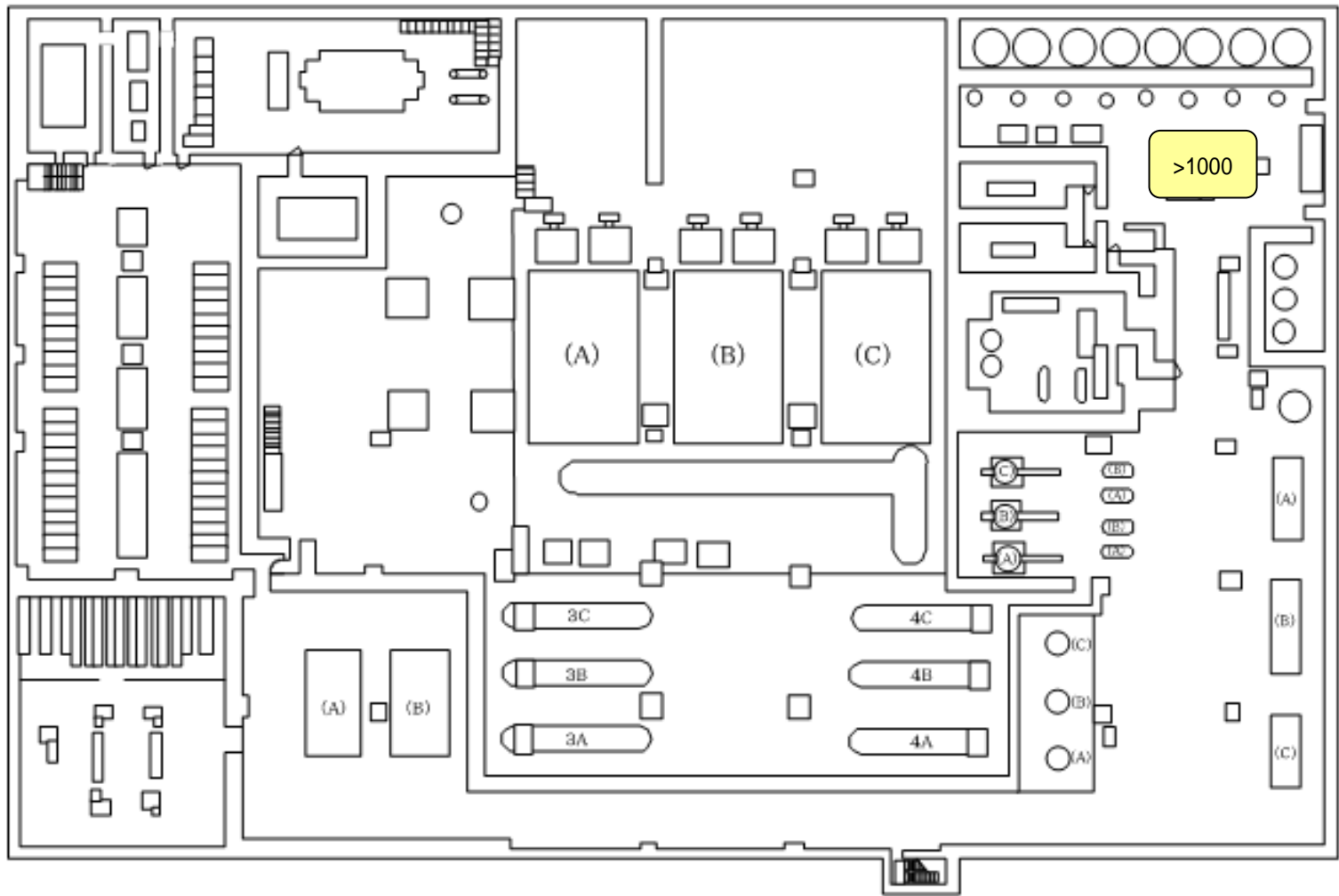

B1, T/B, Unit 2

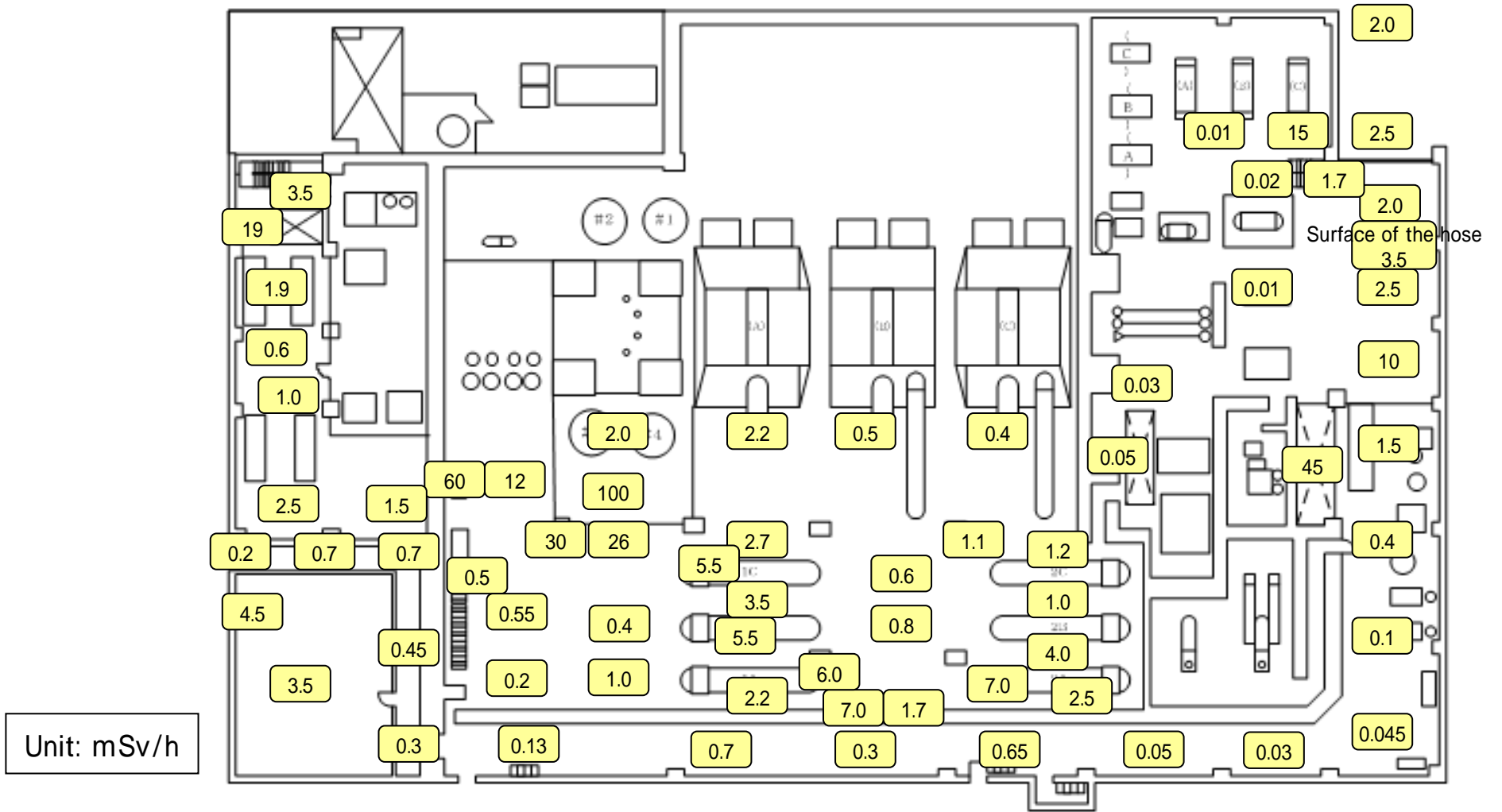

1FL, T/B, Unit 2

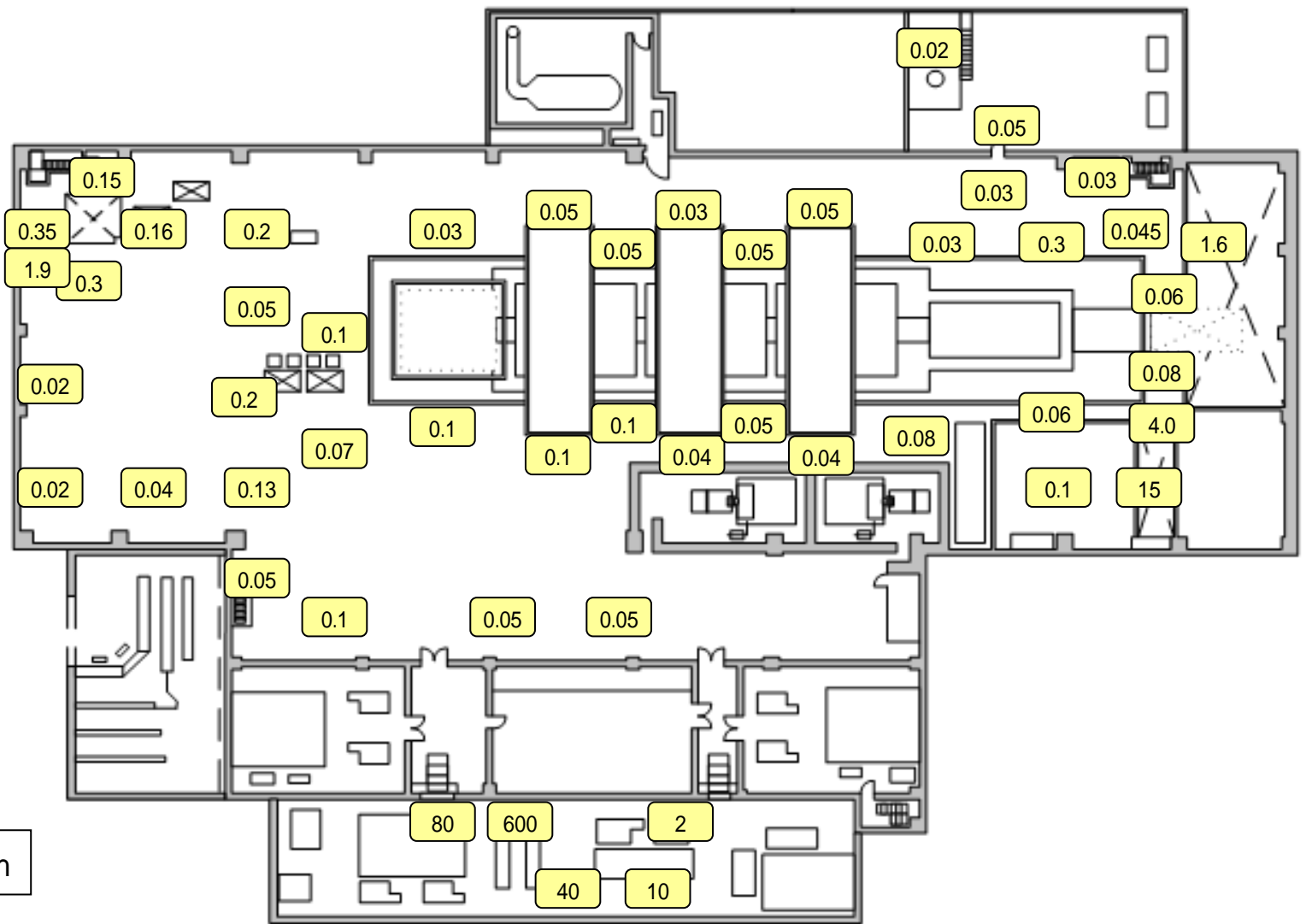

Unit: mSv/h

2FL, T/B, Unit 2

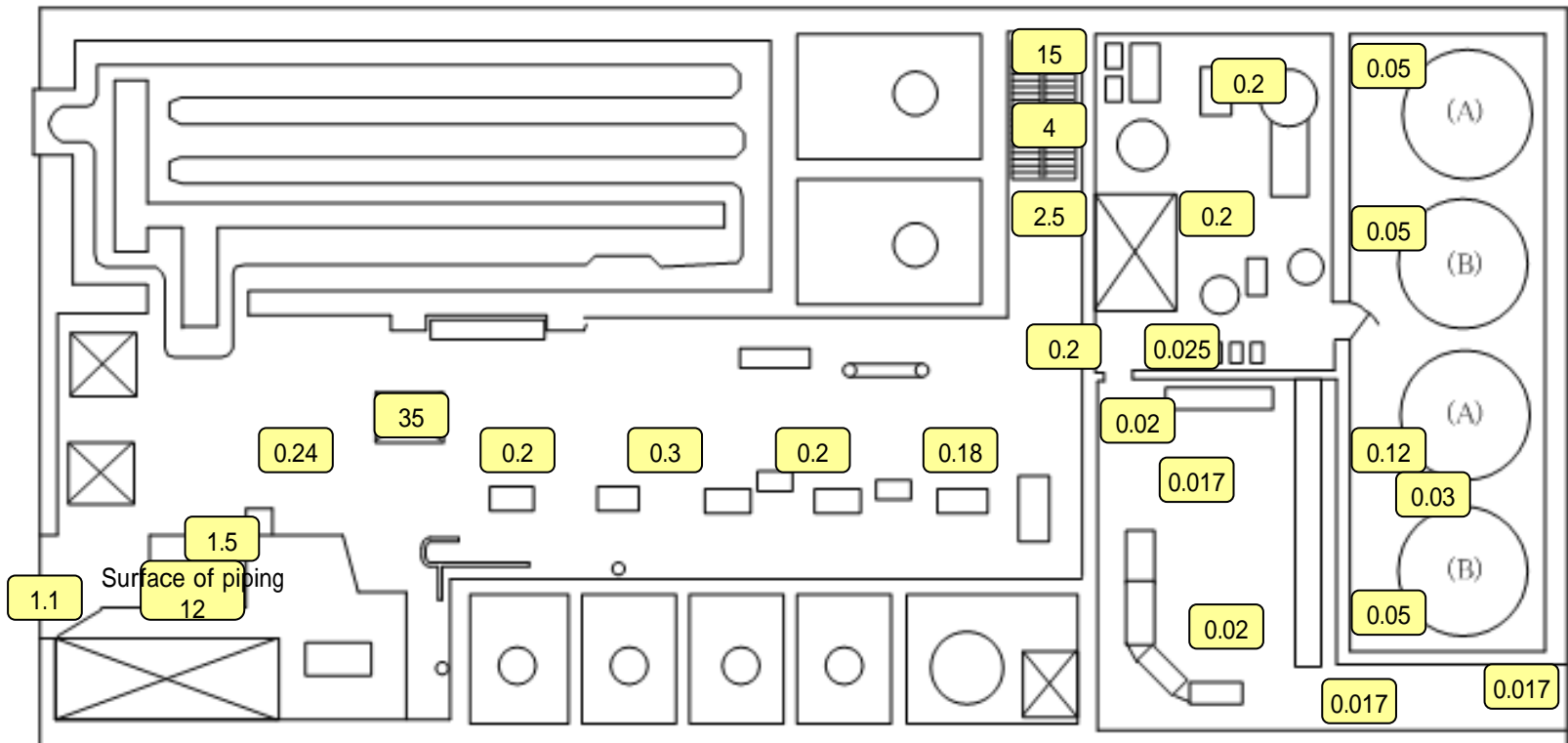

Unit: mSv/h

1FL, Rad Waste Treatment Bldg, Unit 2

Unit: mSv/h

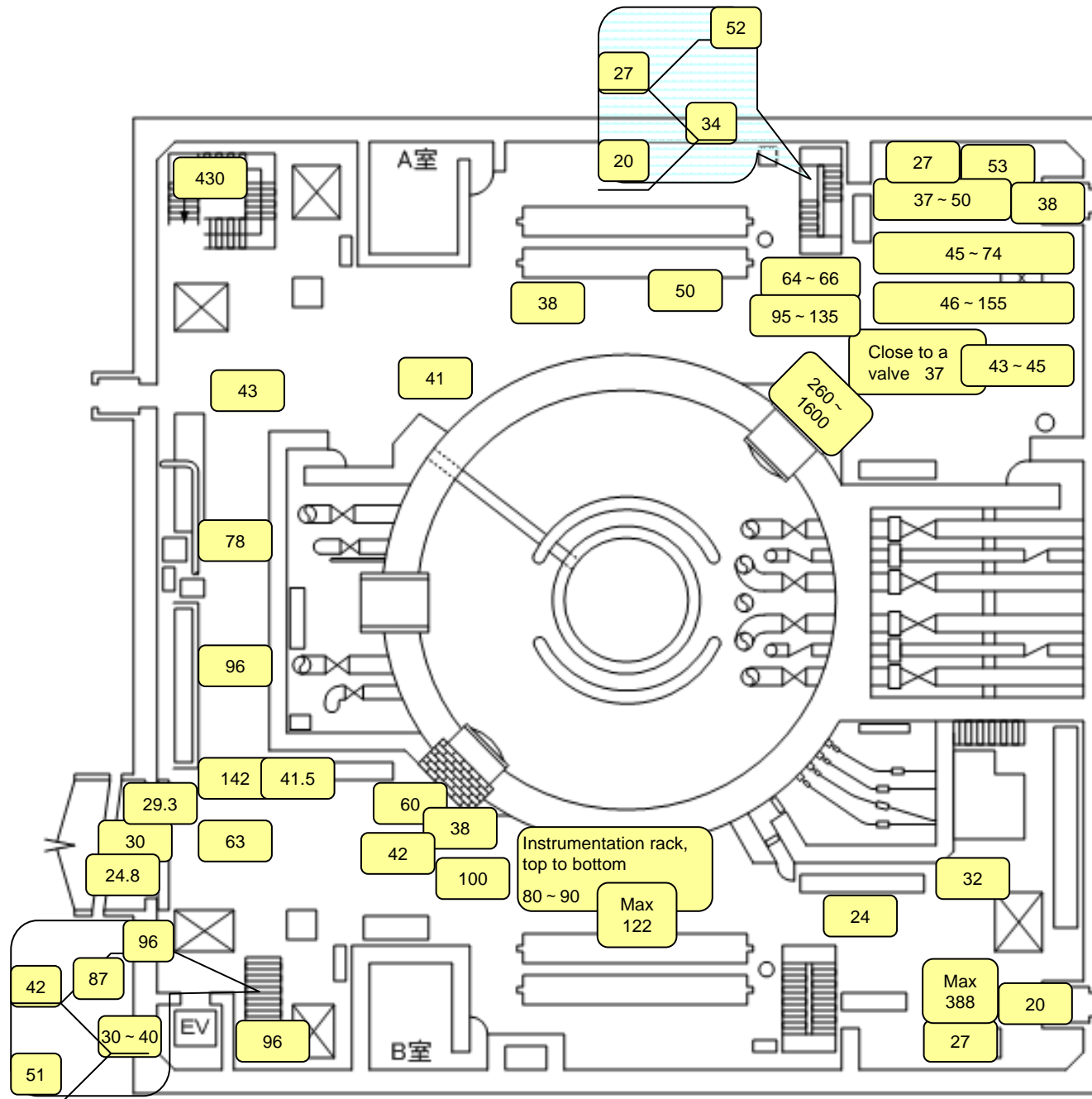

1FL, R/B, Unit 3



Unit: mSv/h

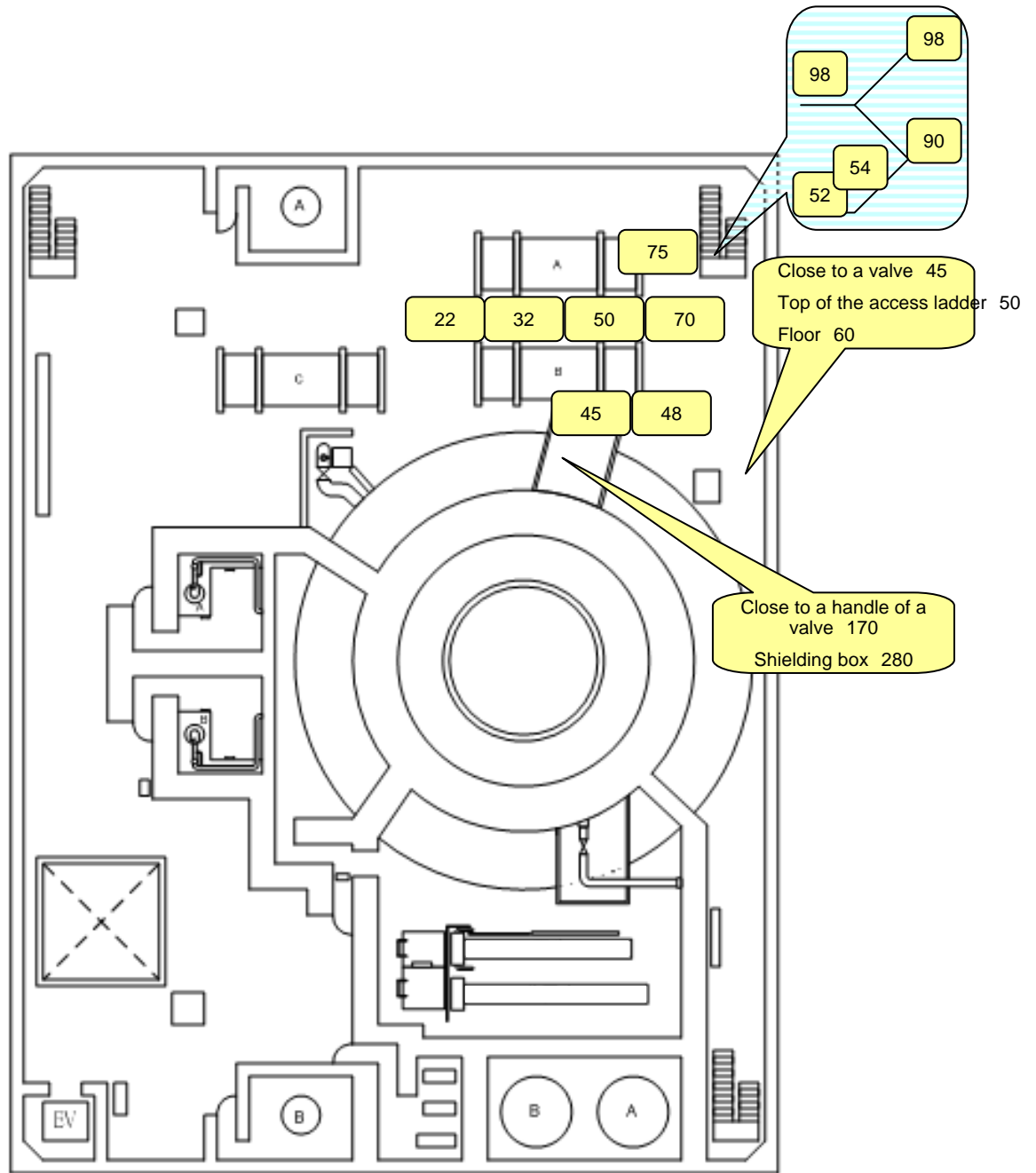

2FL, R/B, Unit 3

Unit: mSv/h

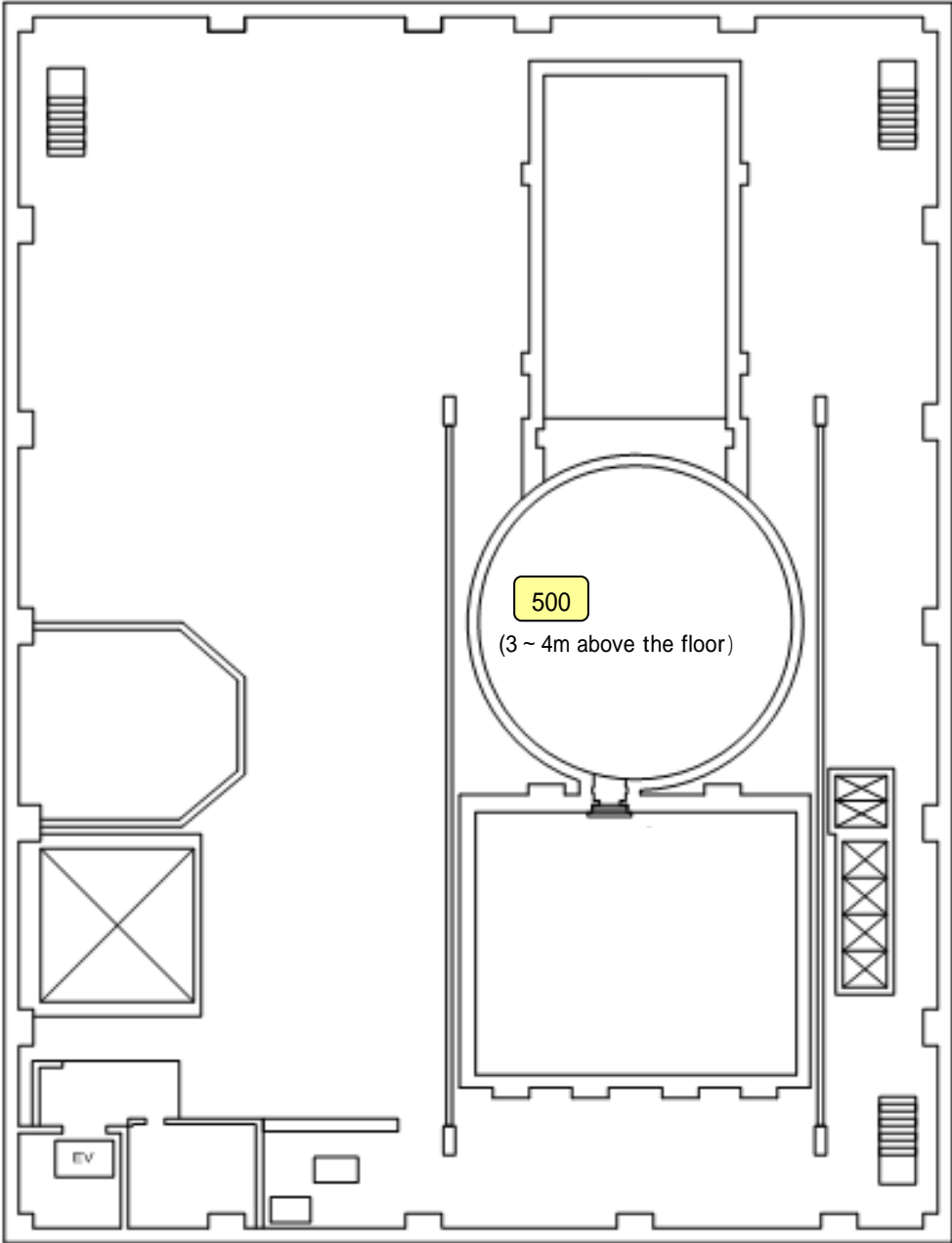

5FL, R/B, Unit 3

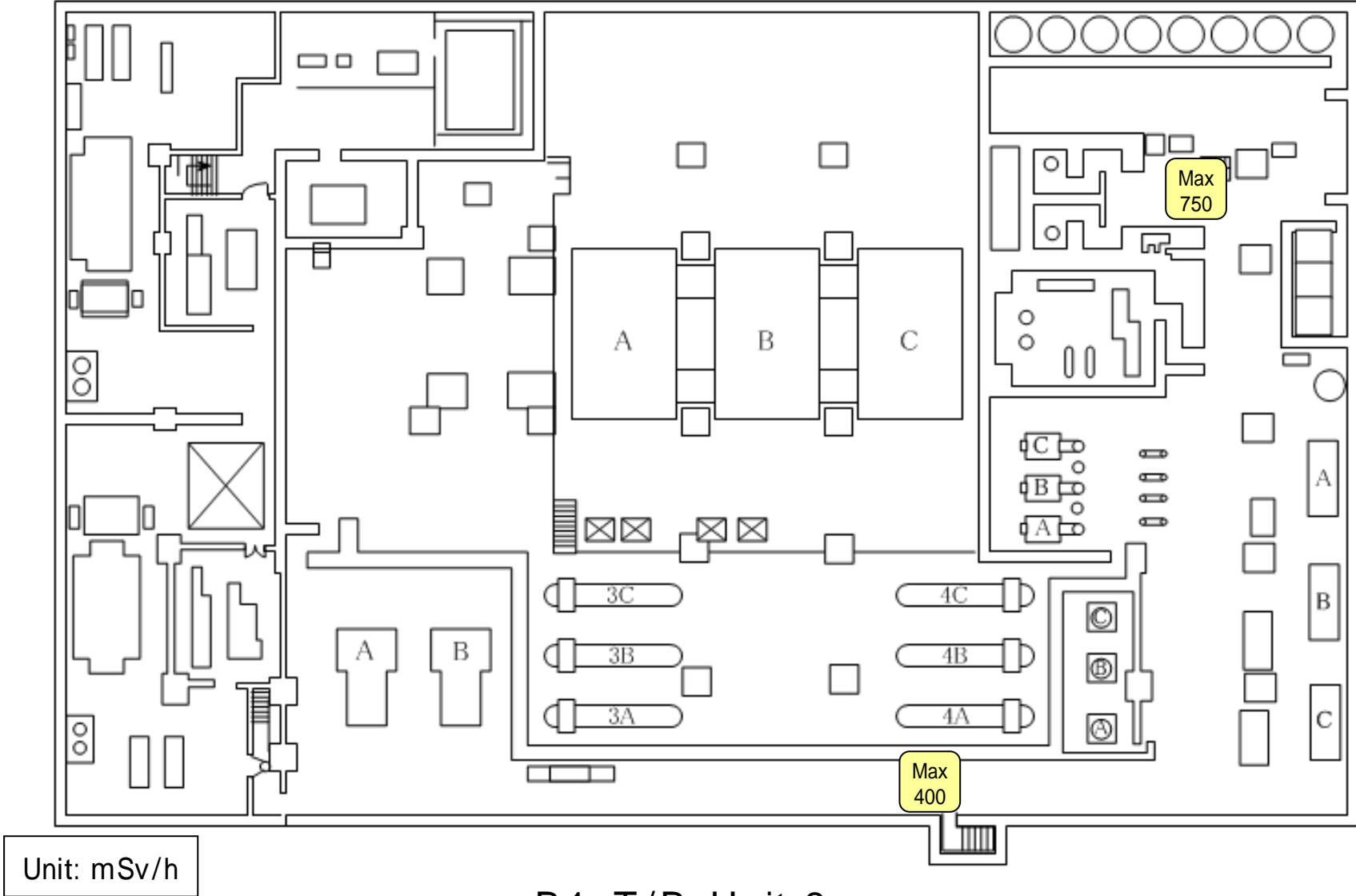

B1, T/B, Unit 3

Unit: mSv/h

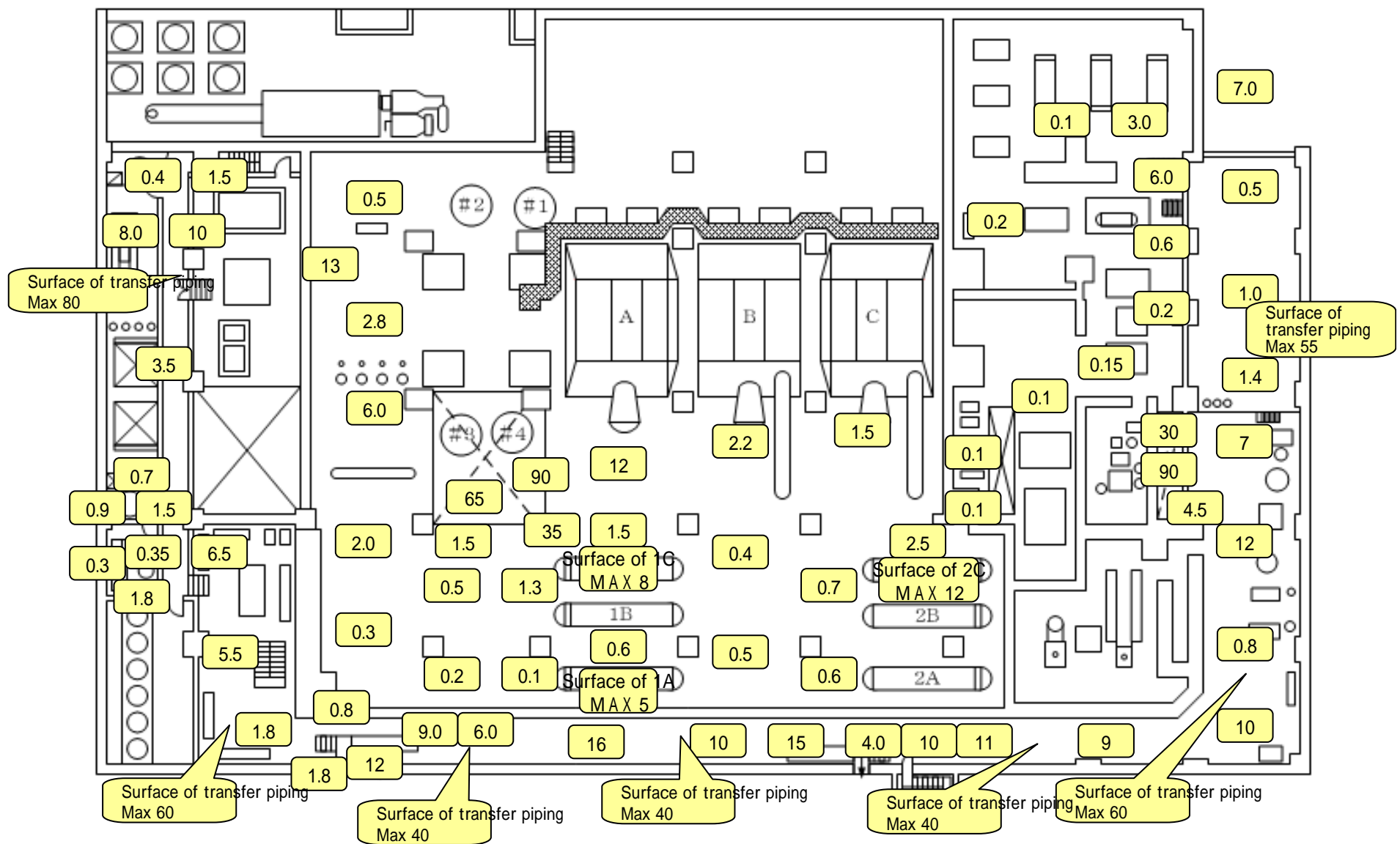

1FL, T/B, Unit 3

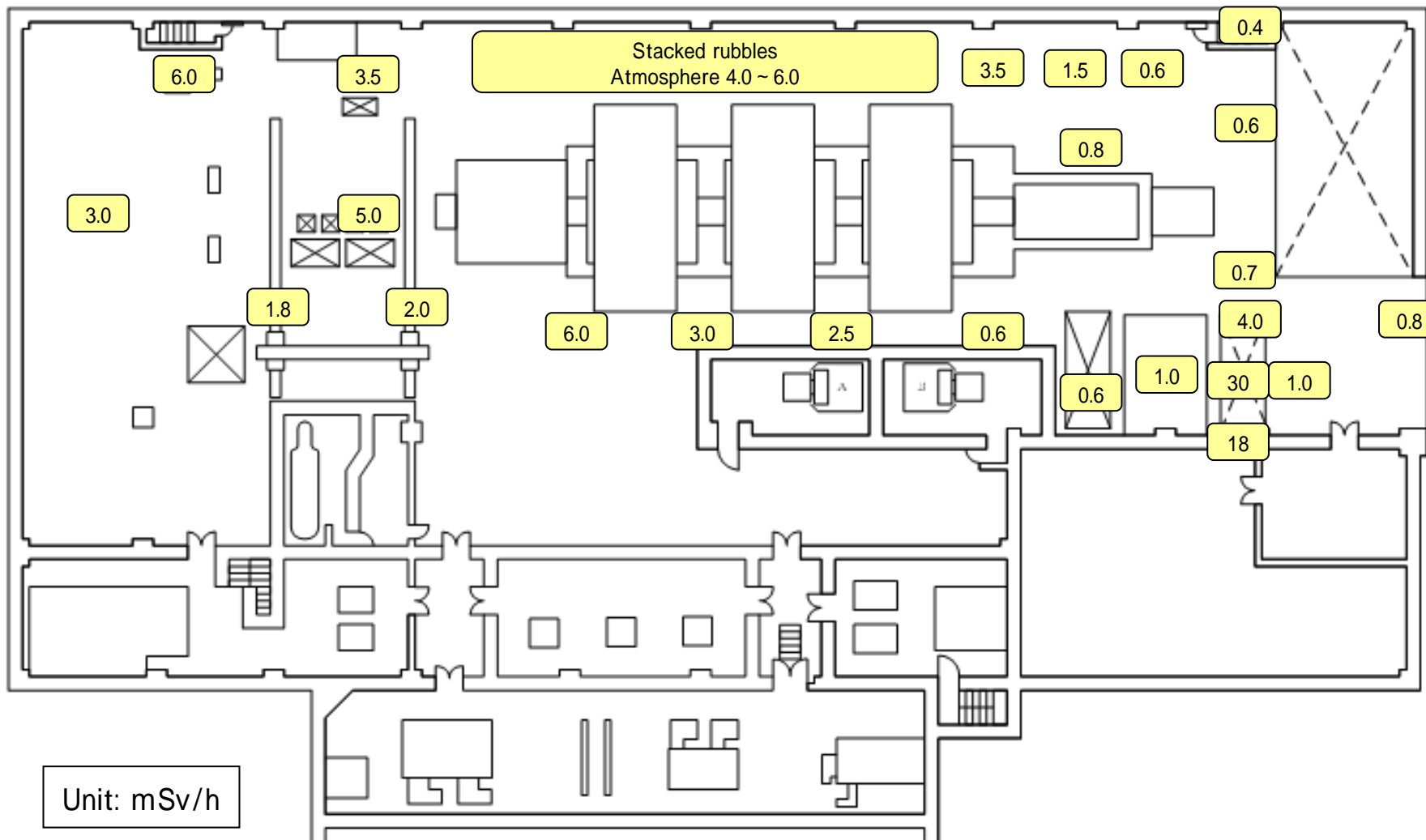

2FL, T/B, Unit 3

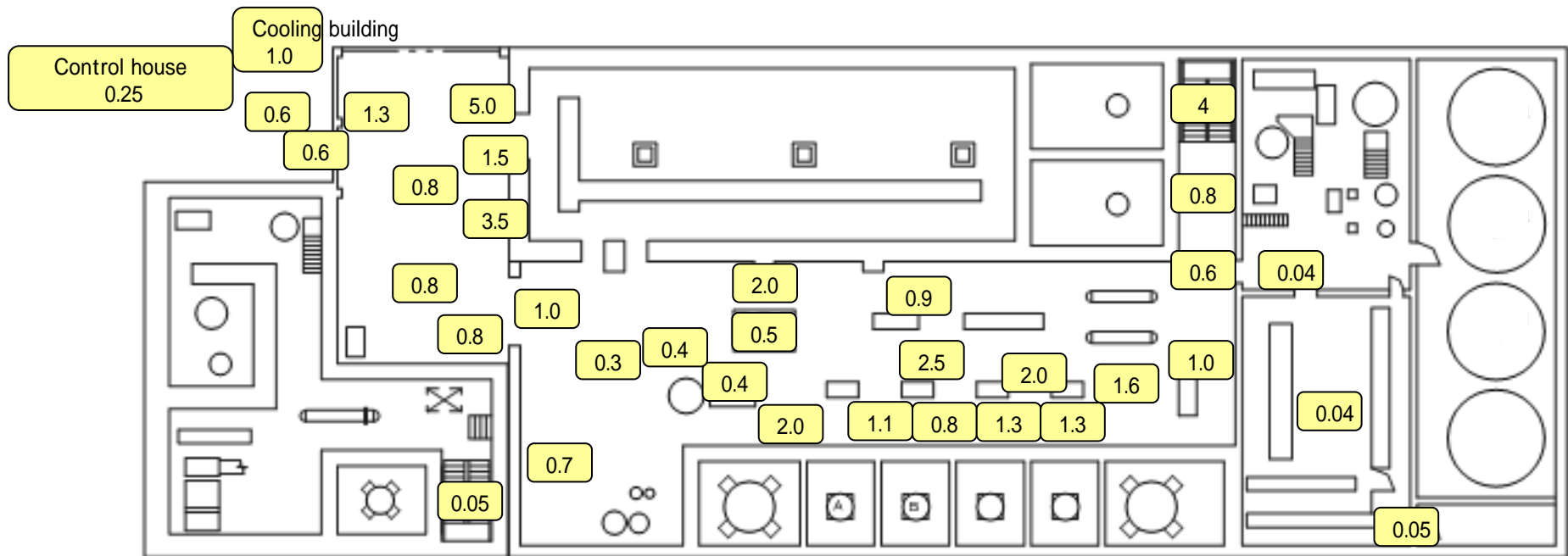

Unit: mSv/h

1FL, Rad Waste Treatment Bldg, Unit 3

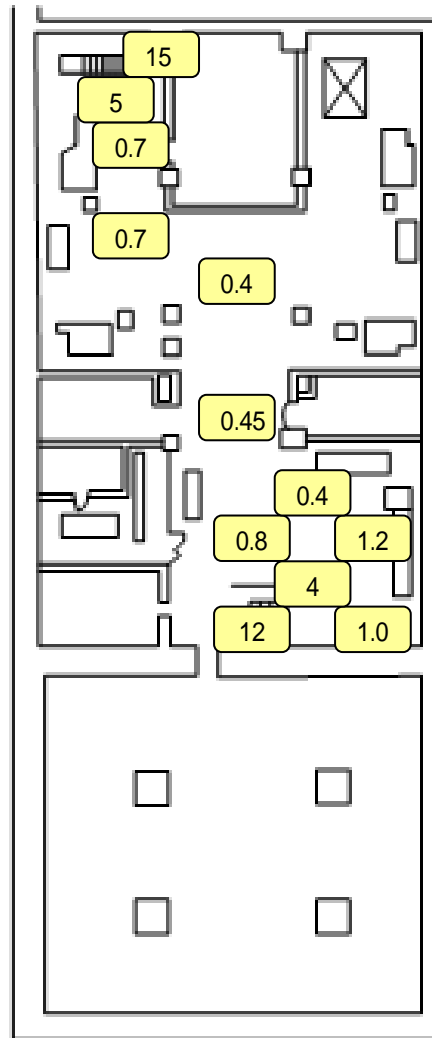

Unit: mSv/h

Basement, Service Bldg, Units 3 & 4

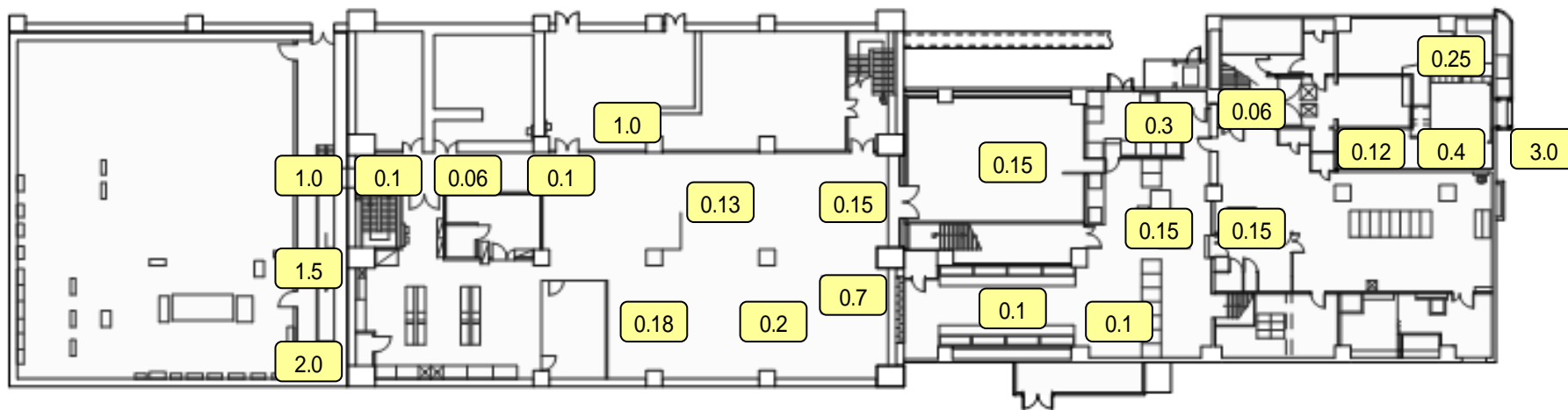

Unit: mSv/h

1FL, Service Bldg, Units 3 & 4



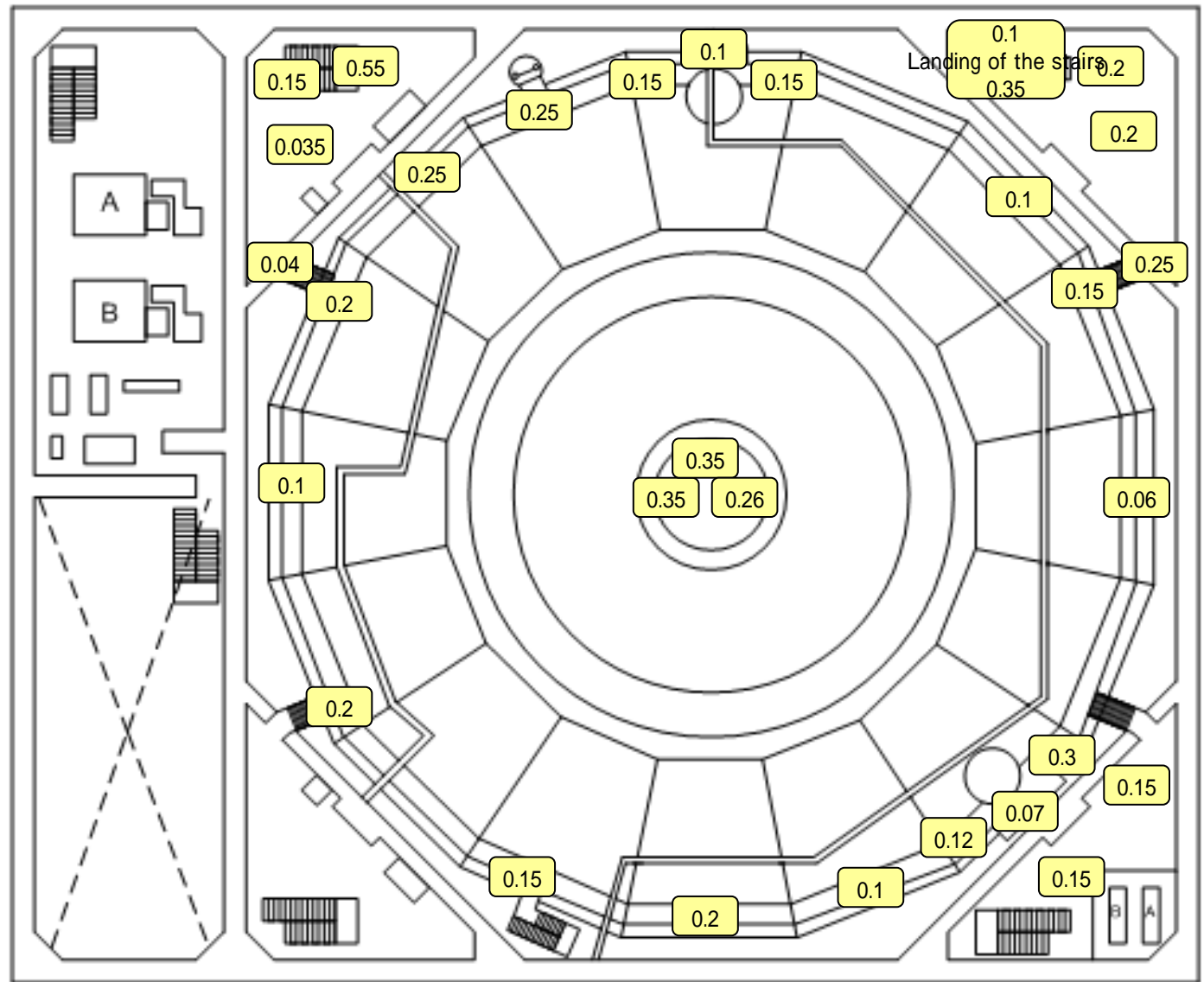

Unit: mSv/h

Basement, R/B, Unit 4

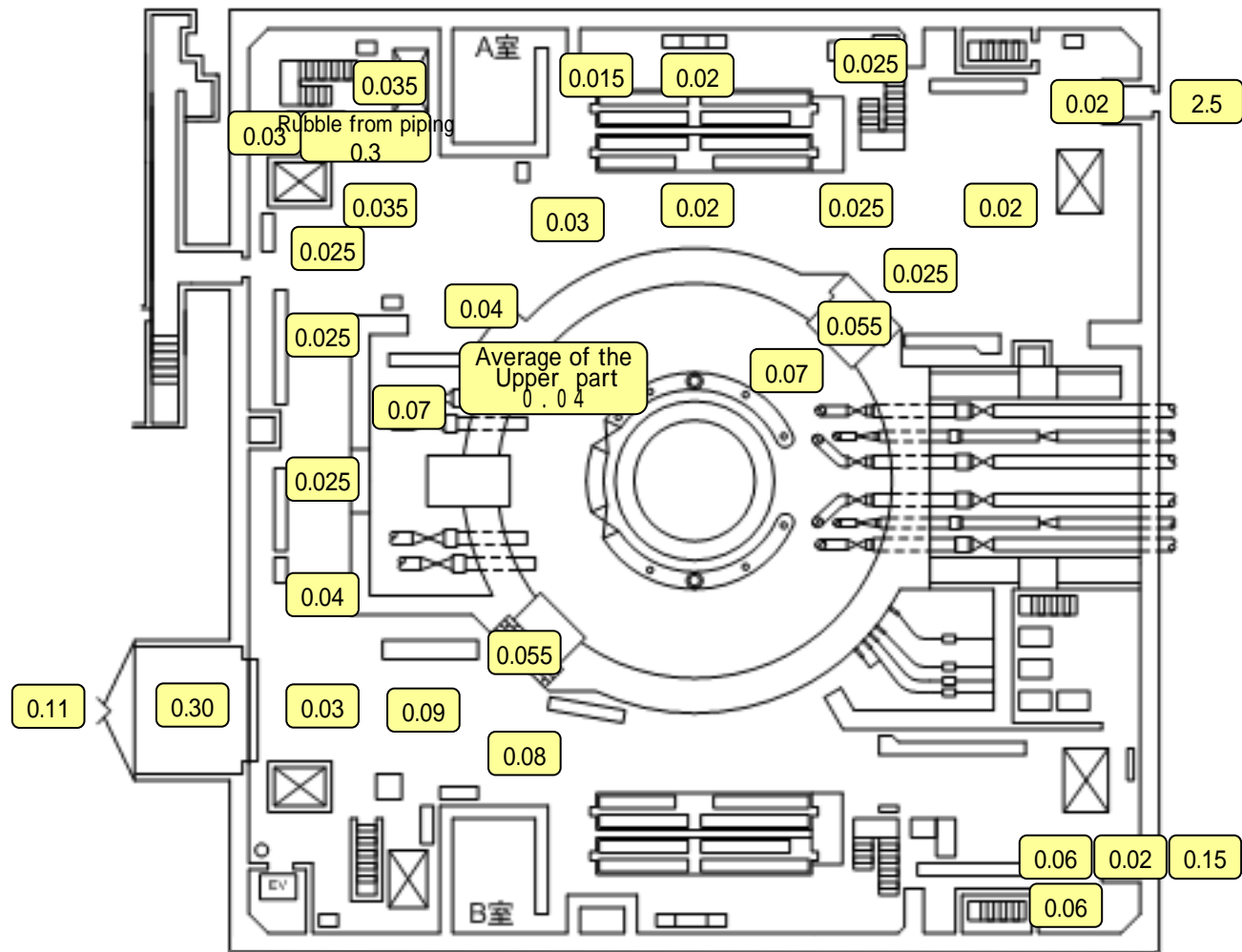

Unit: mSv/h

1FL, R/B, Unit 4

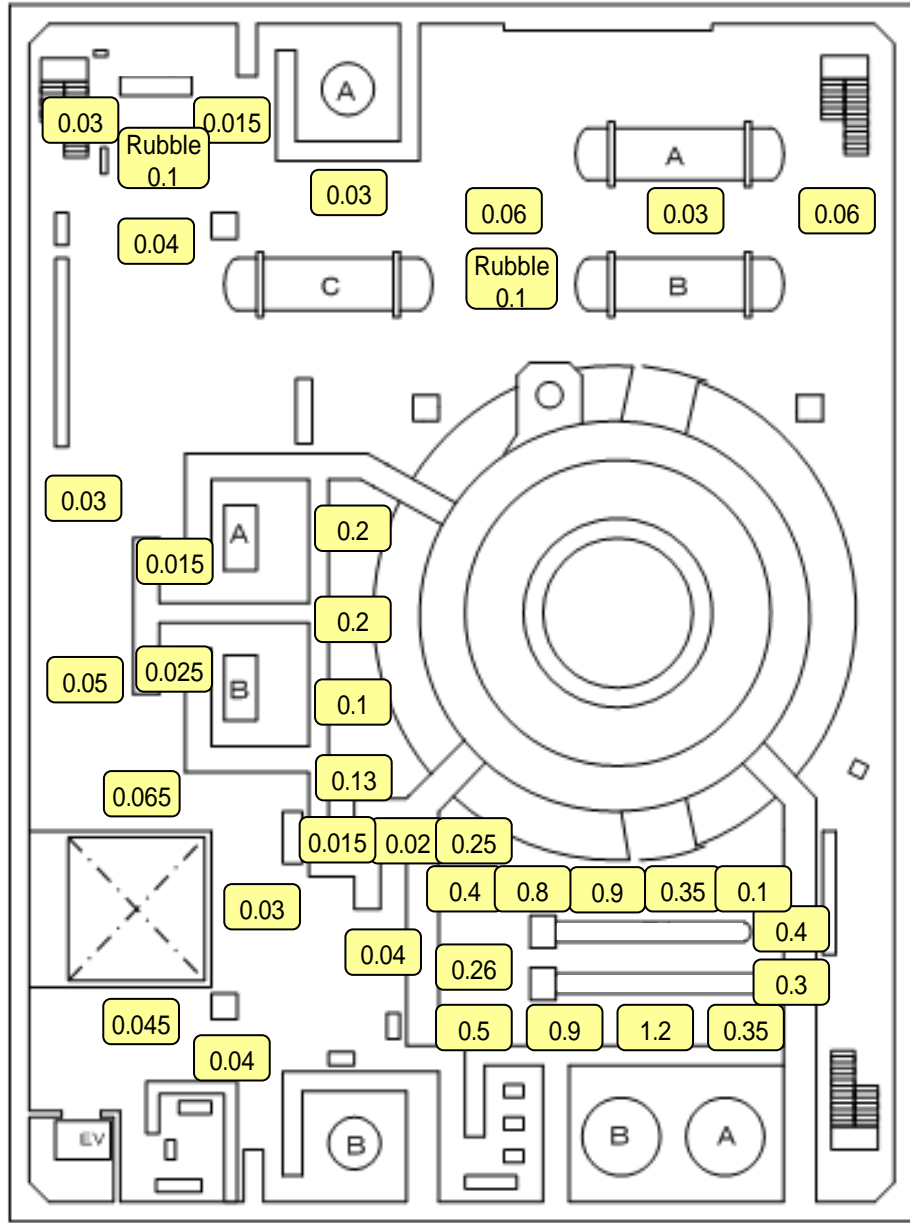

Unit: mSv/h

2FL, R/B, Unit 4

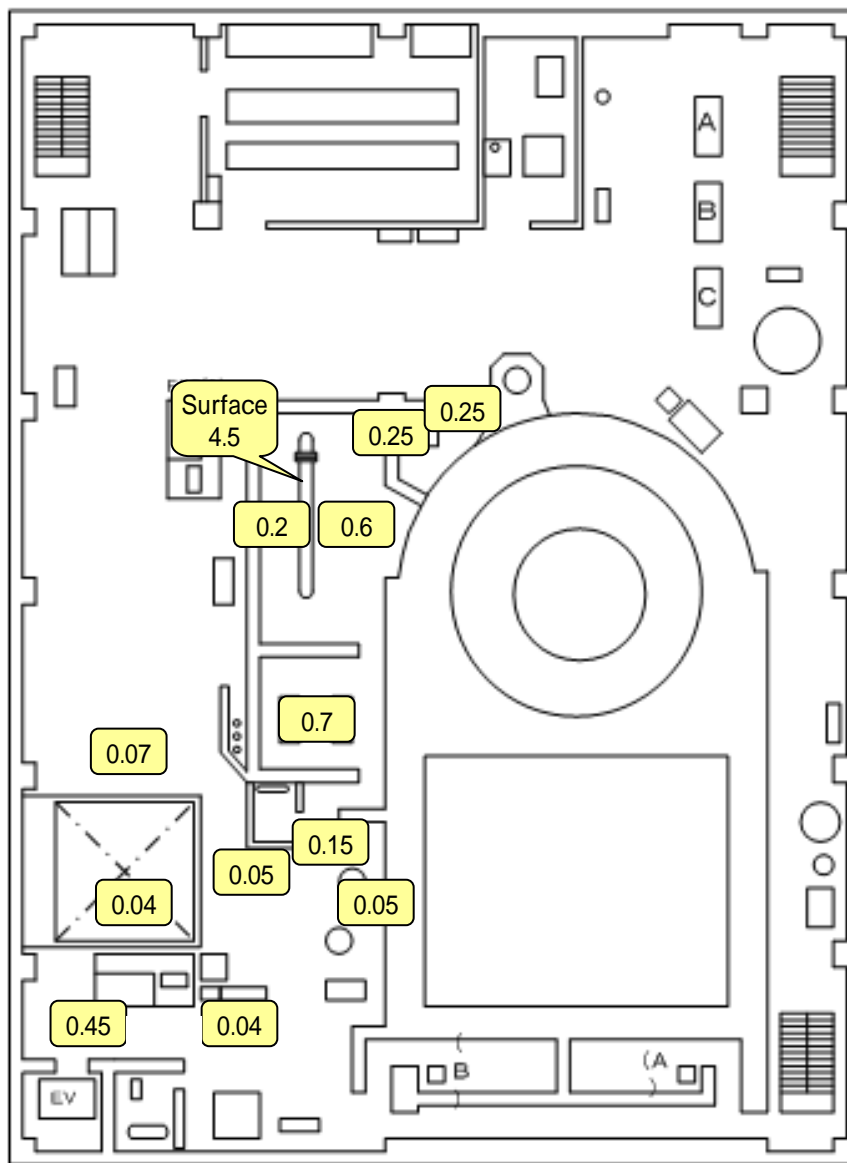

Unit: mSv/h

3FL, R/B, Unit 4

Unit: mSv/h

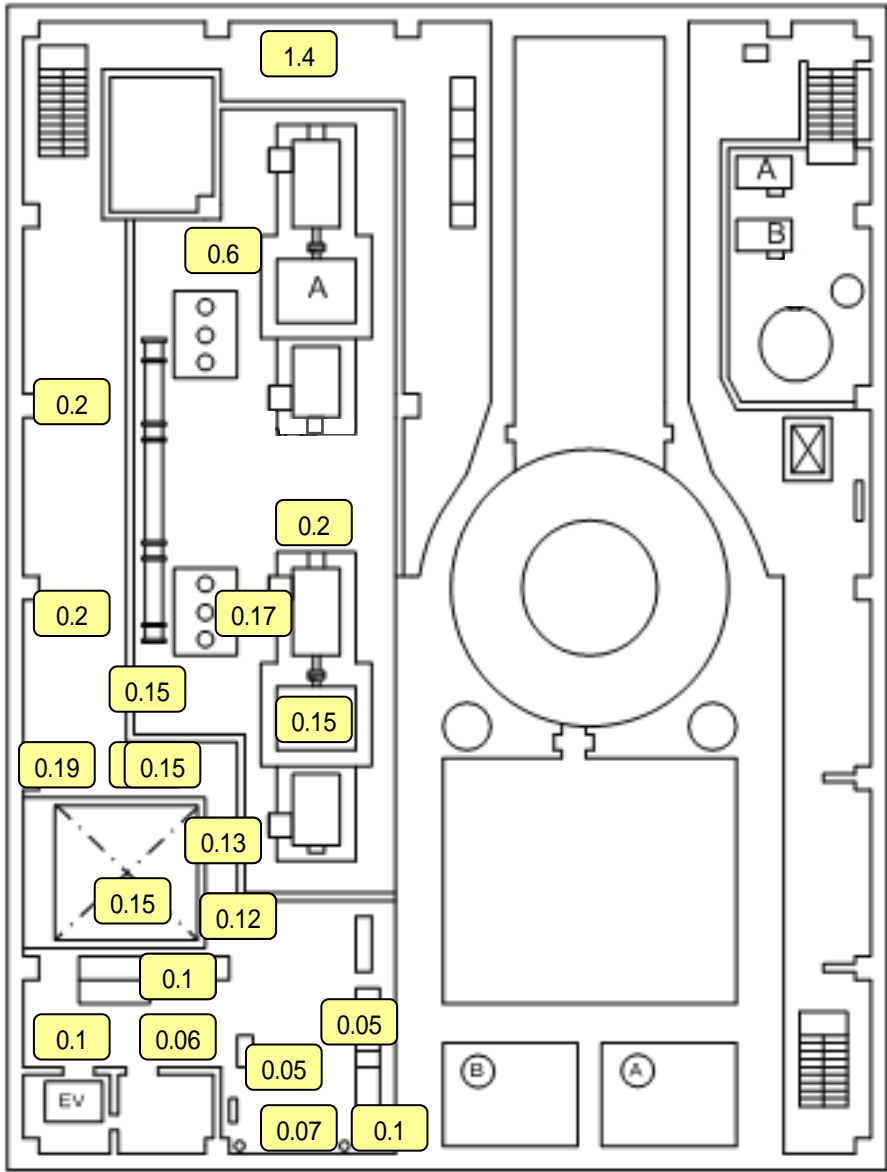

4FL, R/B, Unit 4

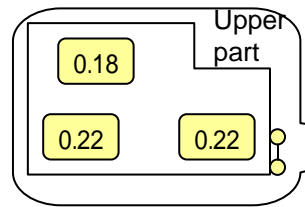
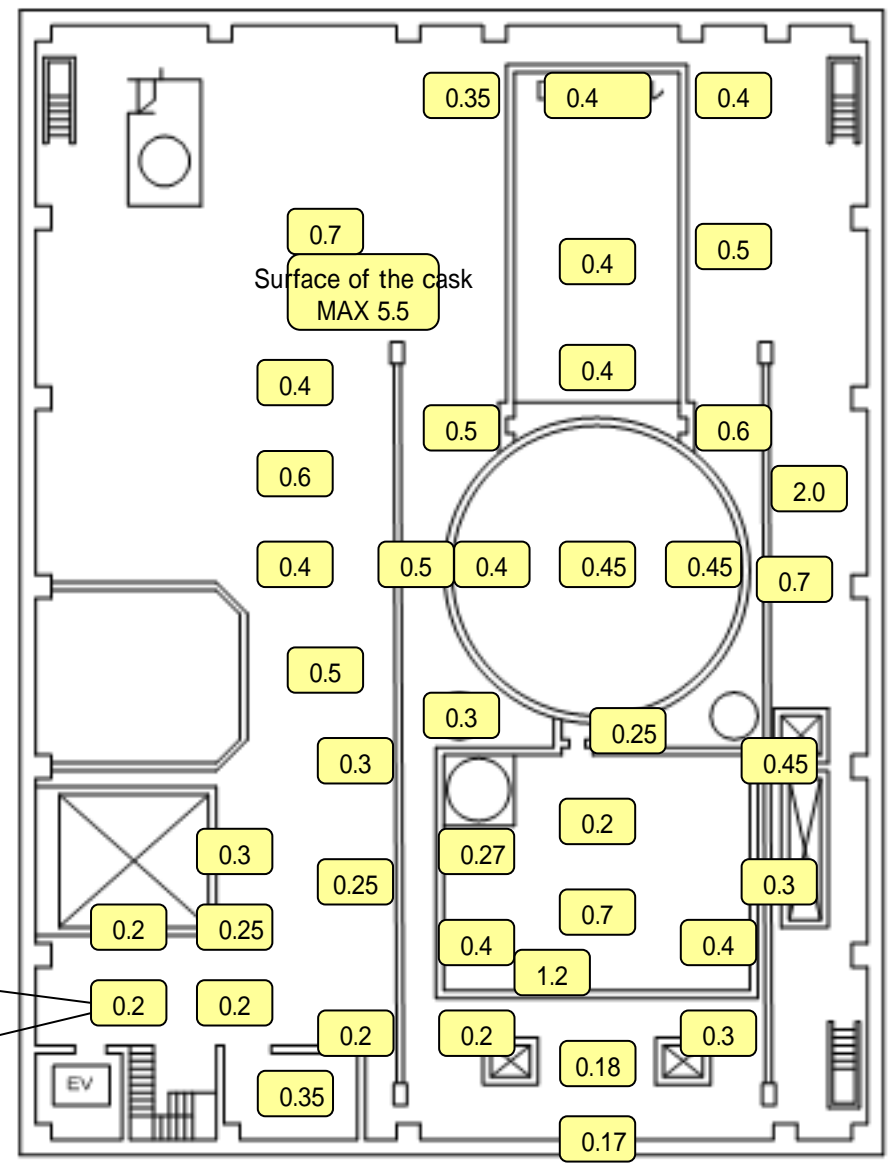
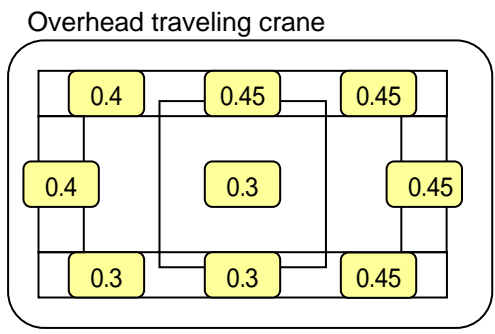

Unit: mSv/h

5FL, R/B, Unit 4

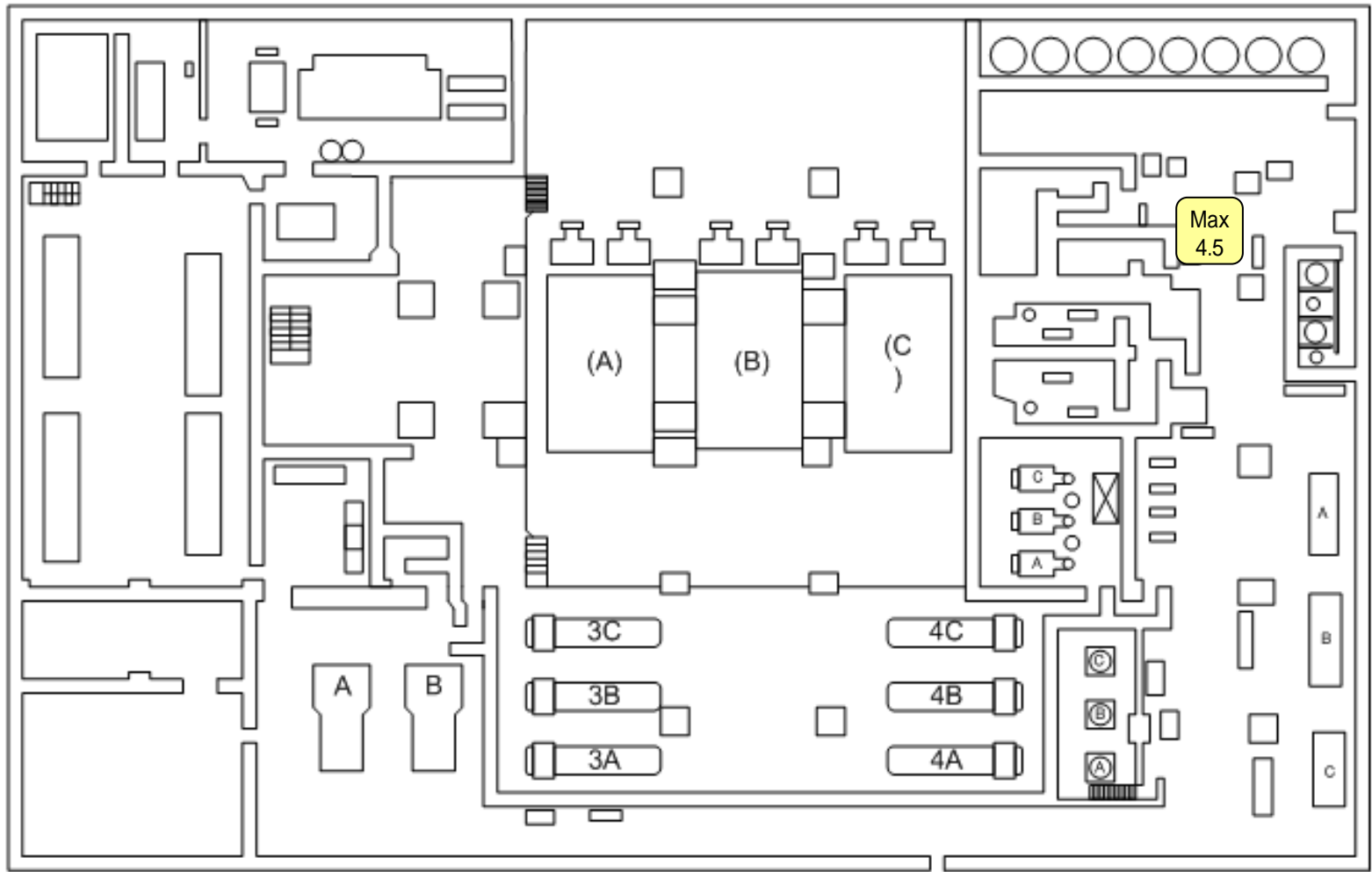

Unit: mSv/h

B1, T/B, Unit 4

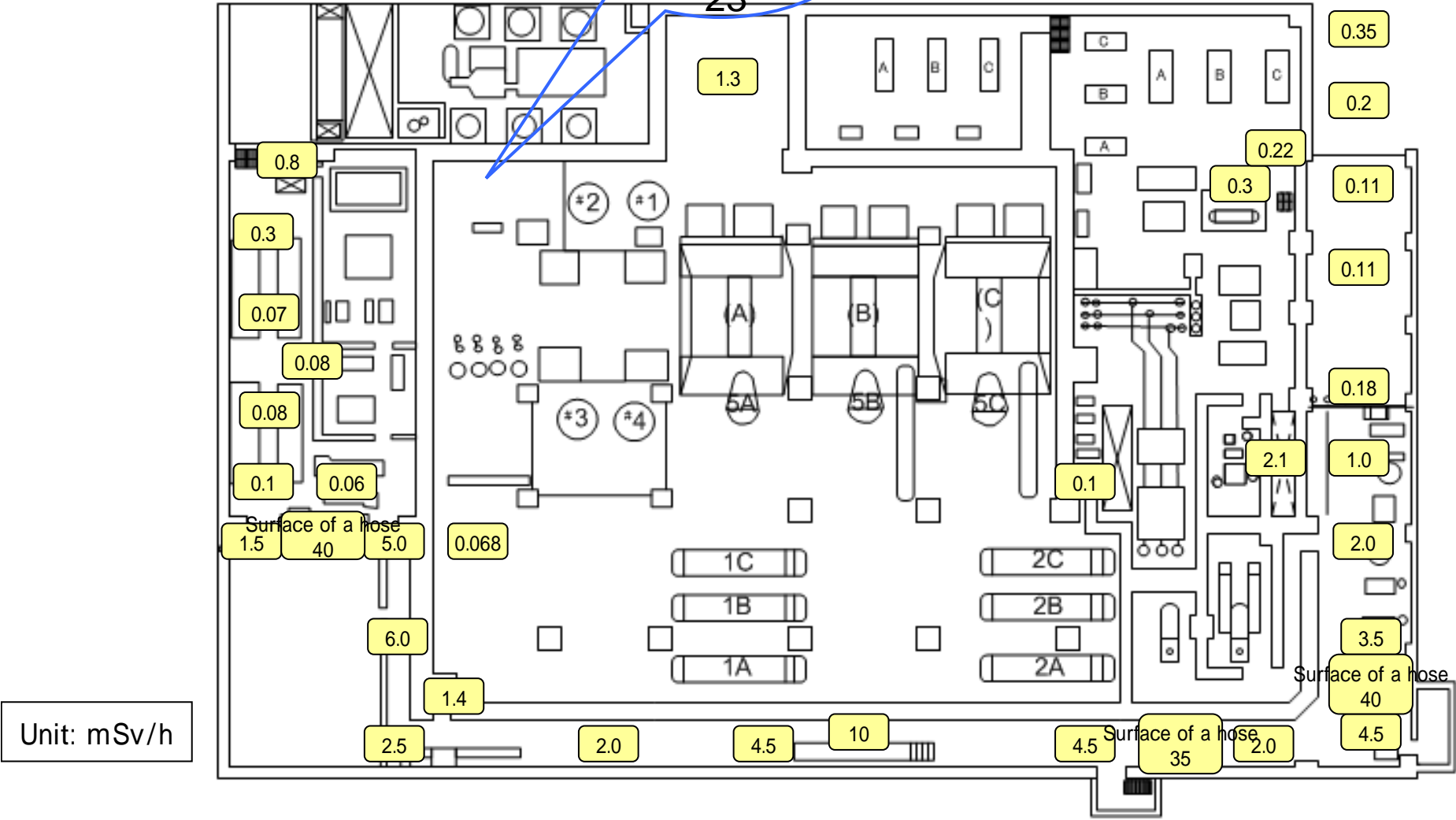
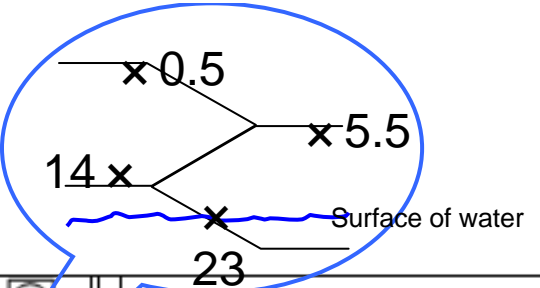

1FL, T/B, Unit 4



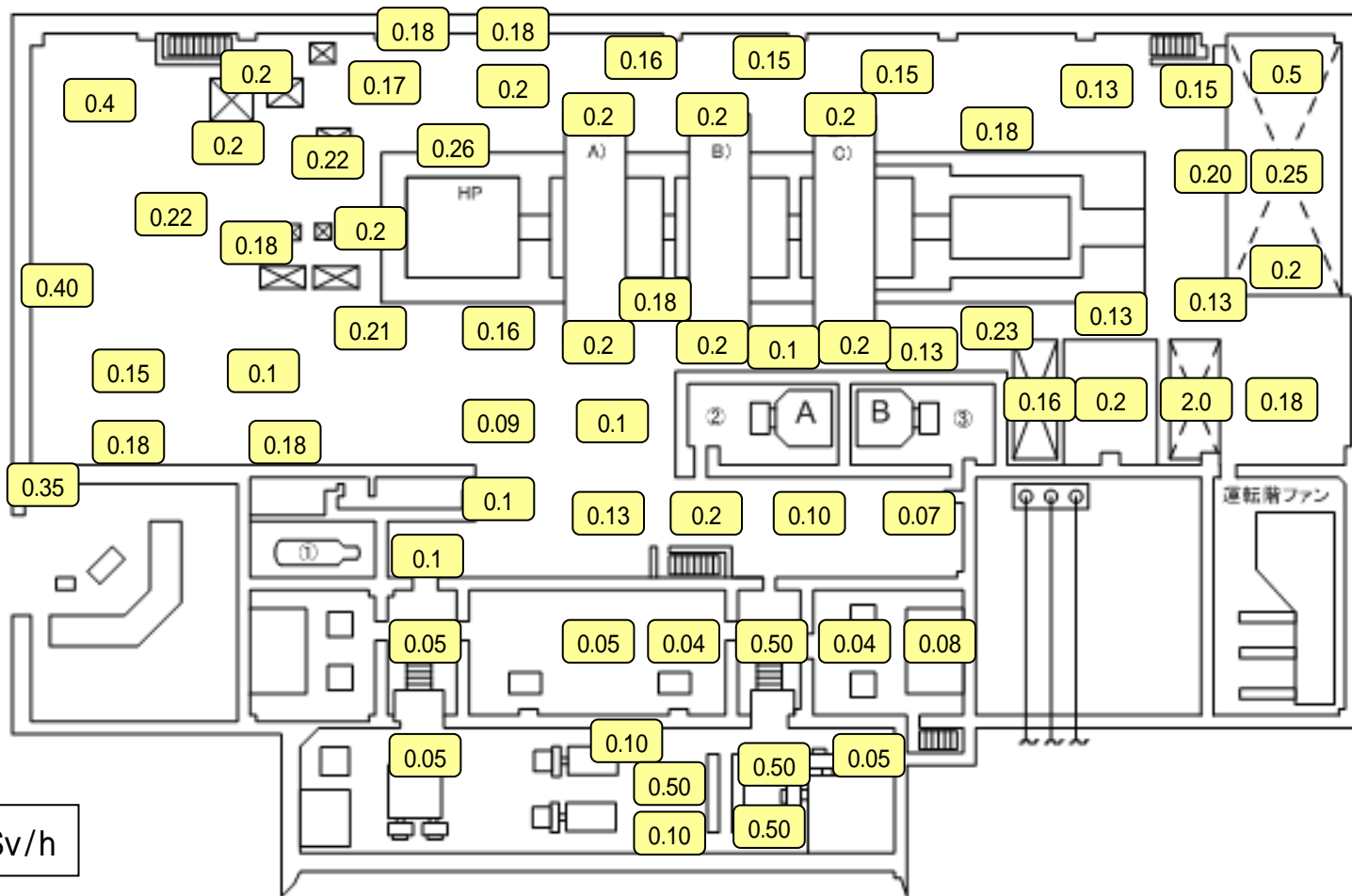

2FL, T/B, Unit 4

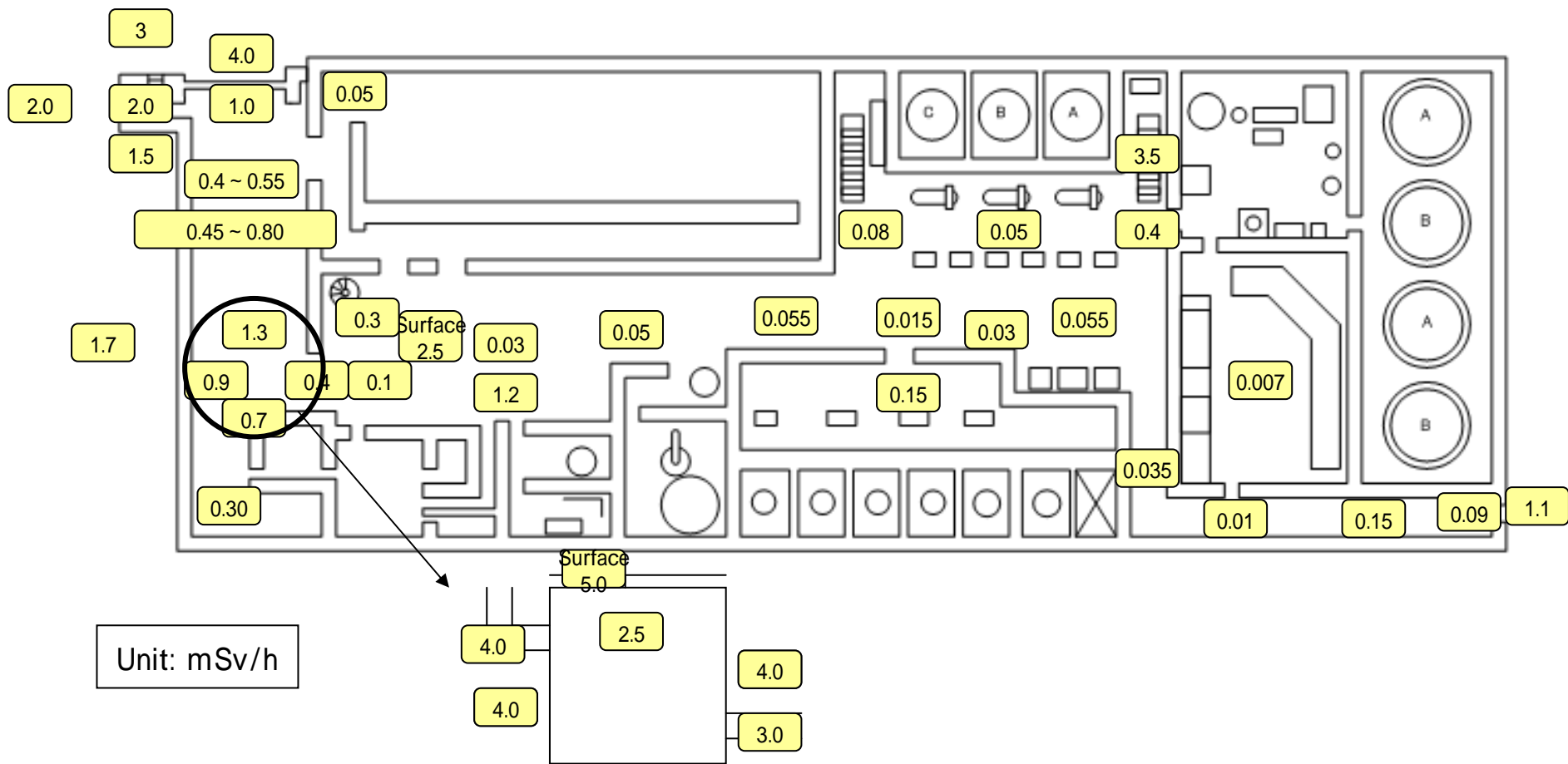

1FL, Rad Waste Treatment Bldg, Unit 4

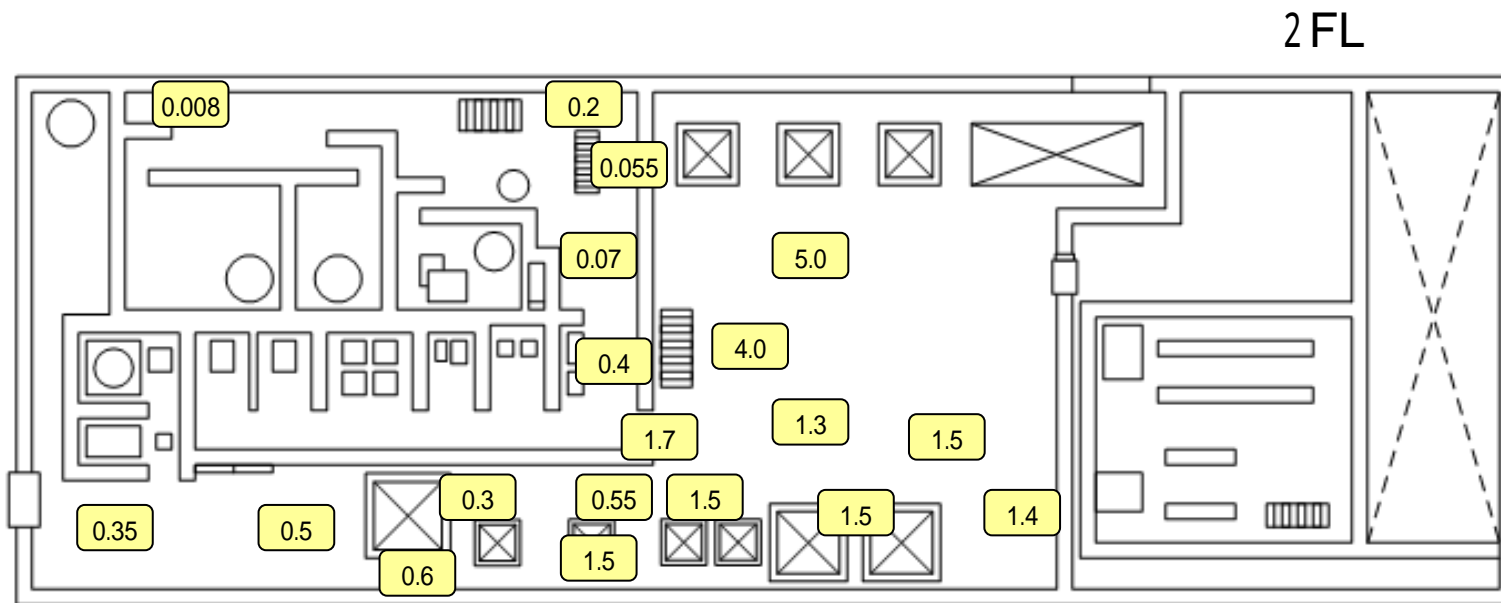

4 FL

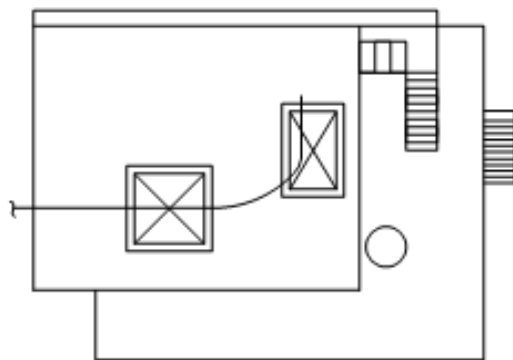

3 FL

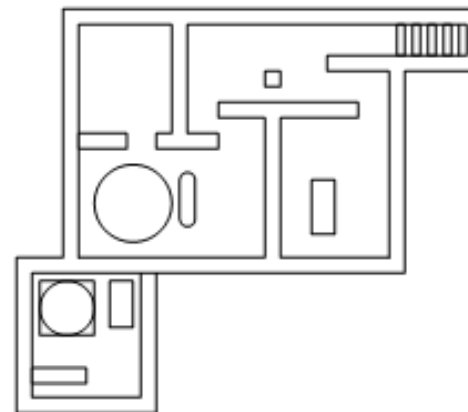

Unit: mSv/h

2, 3 and 4FL, Rad Waster Treatment Bldg,  
Unit 4

Unit: mSv/h

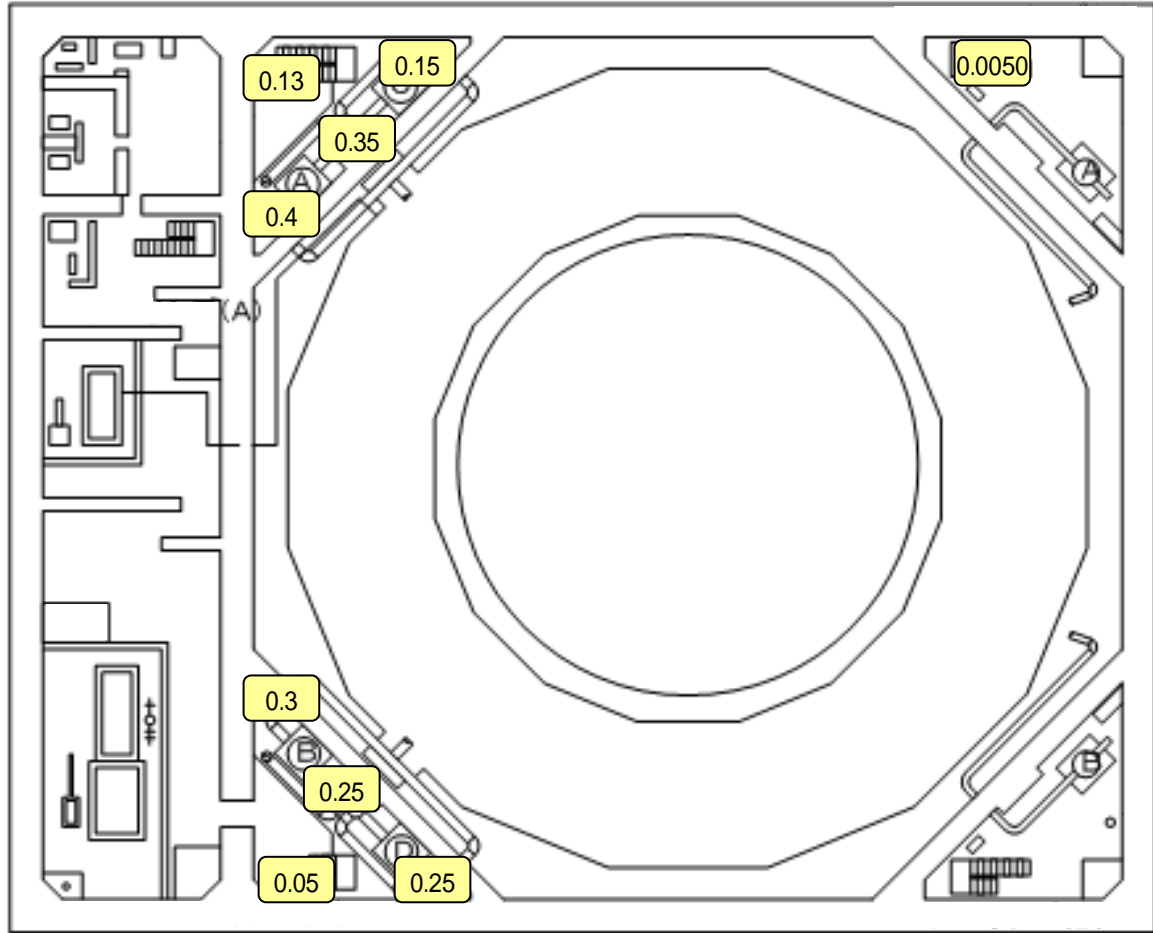

B1, R/B, Unit 5

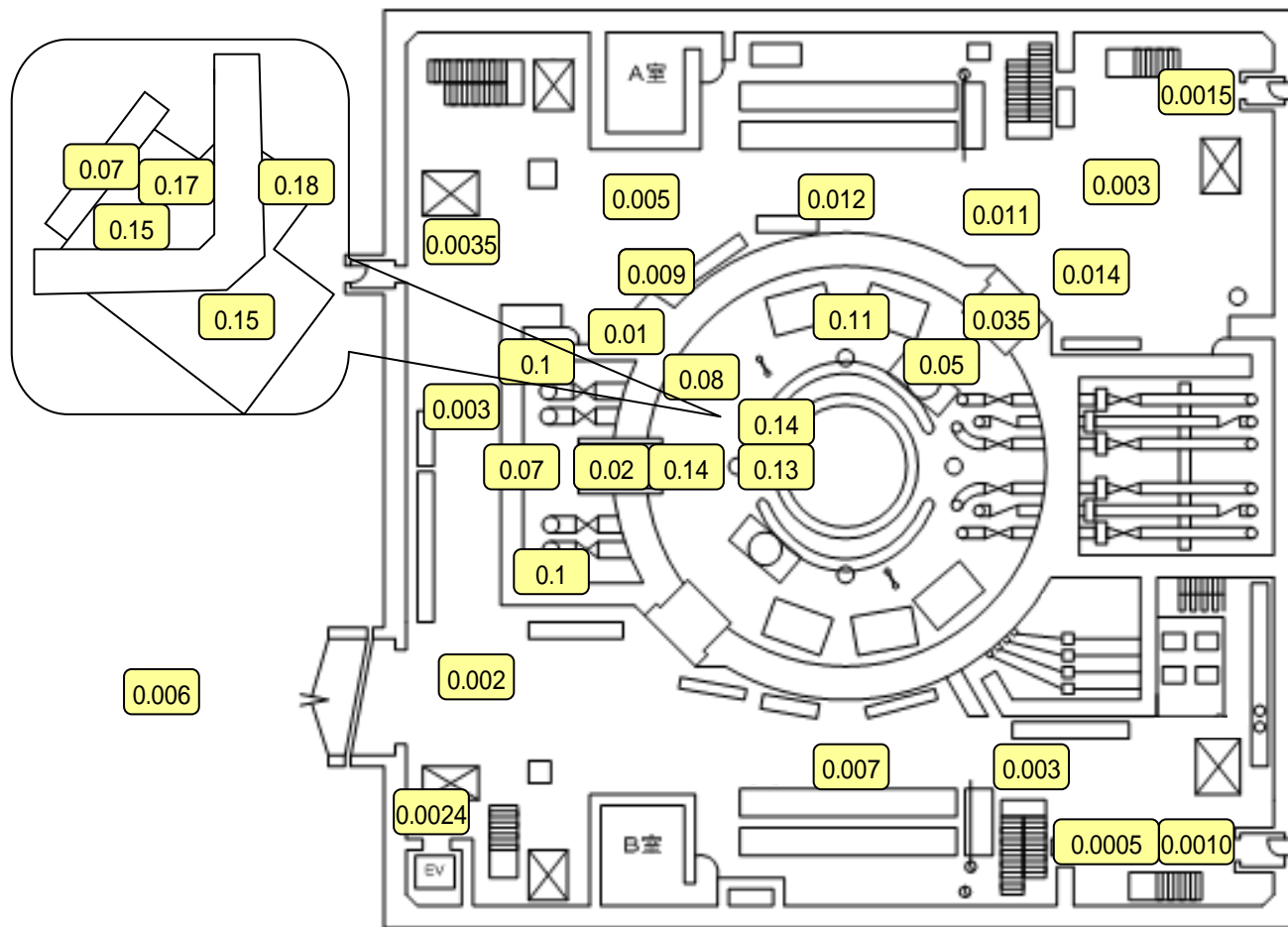

Unit: mSv/h

1FL, R/B, Unit 5

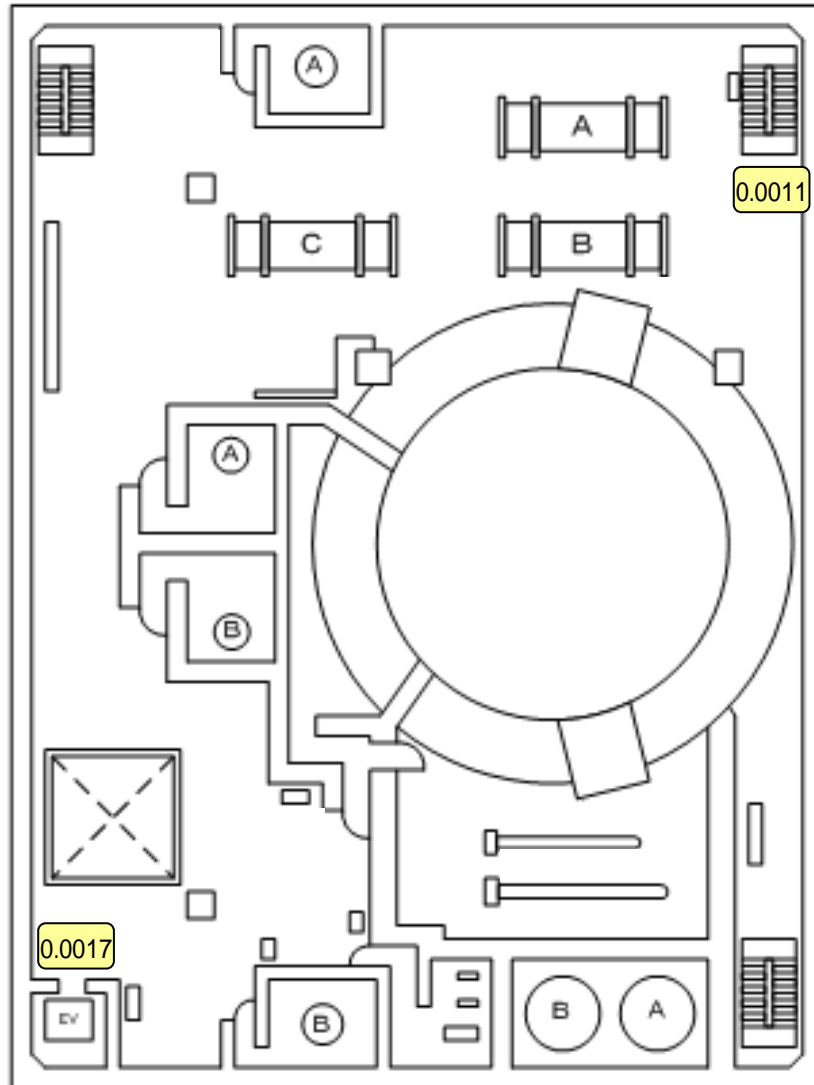

Unit: mSv/h

2FL, R/B, Unit 5

Unit: mSv/h

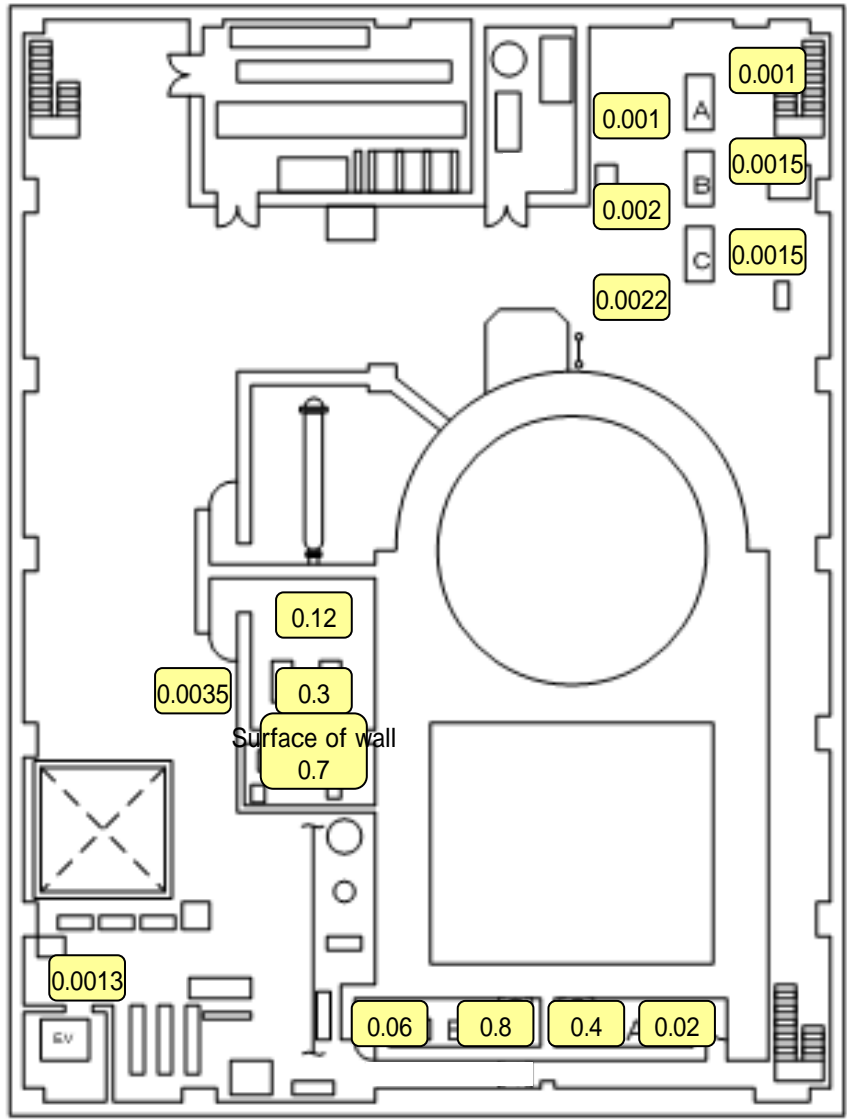

3FL, R/B, Unit 5

Unit: mSv/h

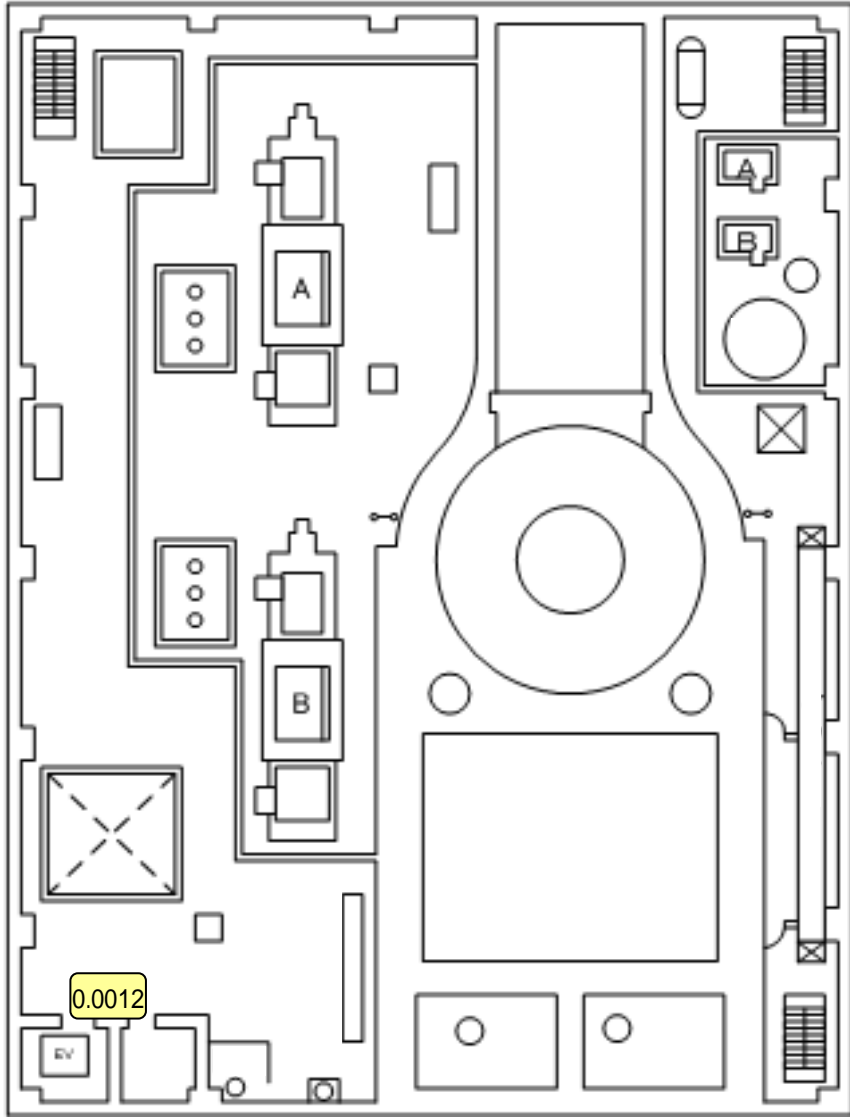

4FL, R/B, Unit 5



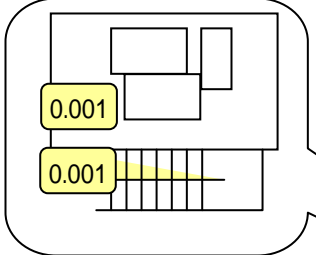
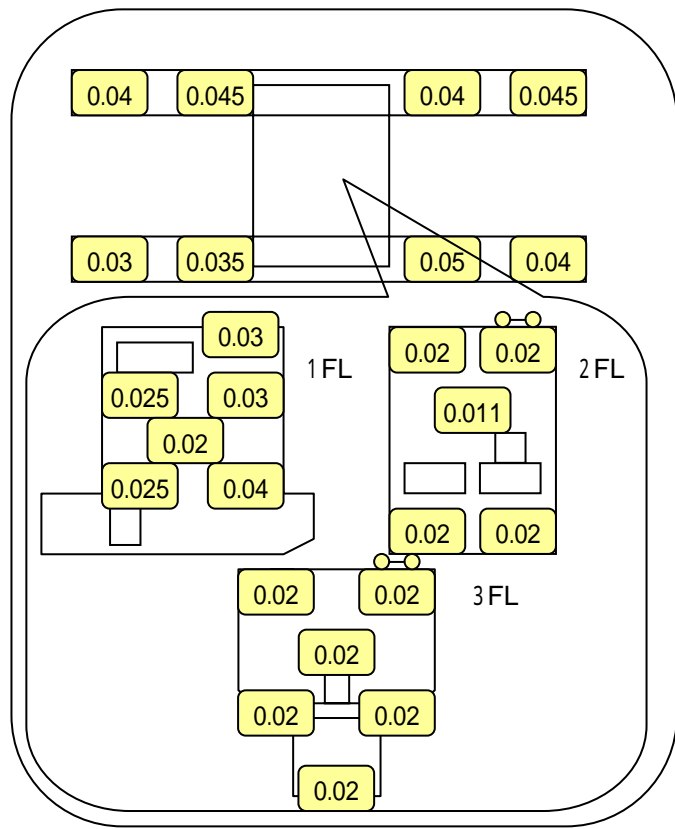

Unit: mSv/h

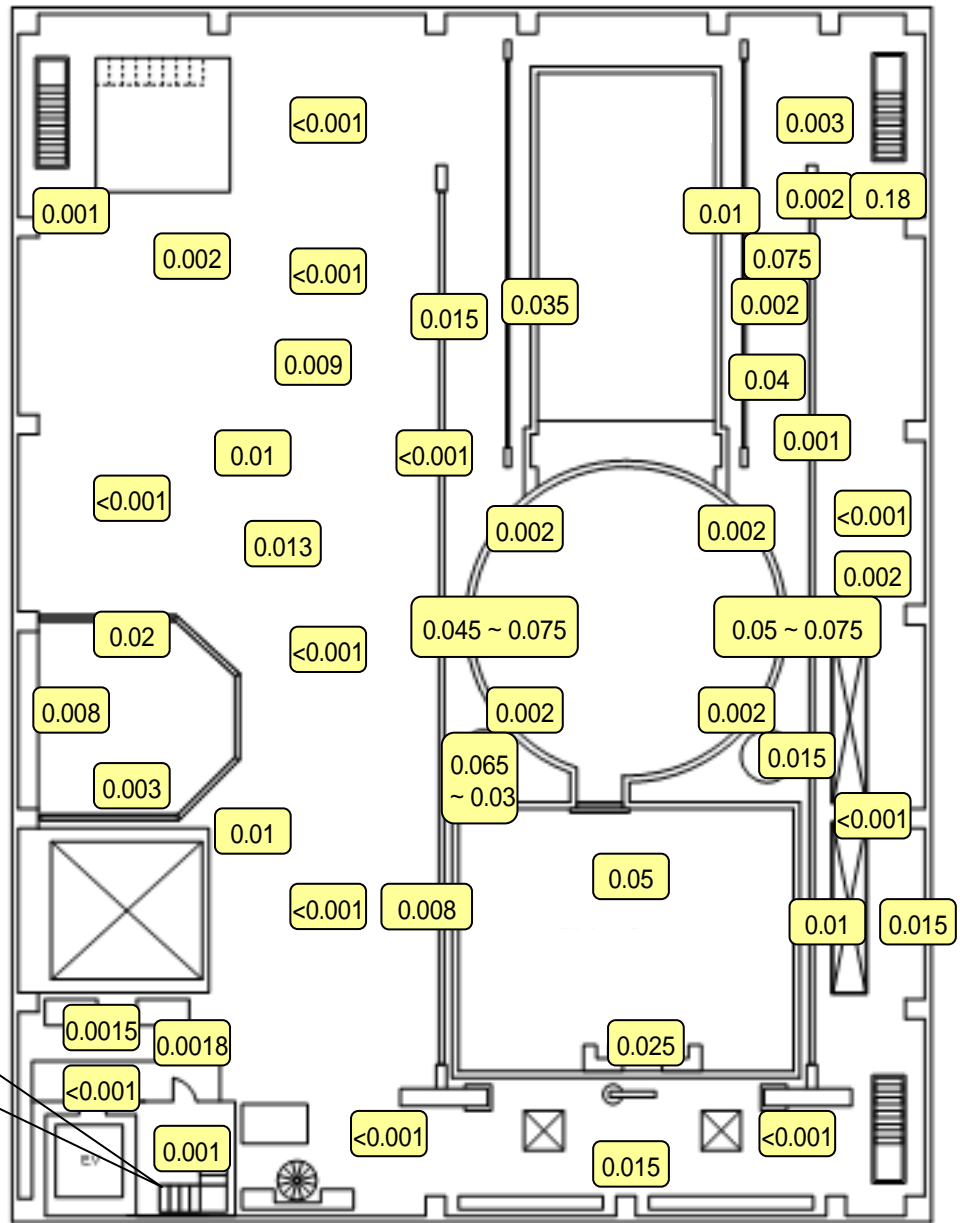

5FL, R/B, Unit 5

Unit: mSv/h

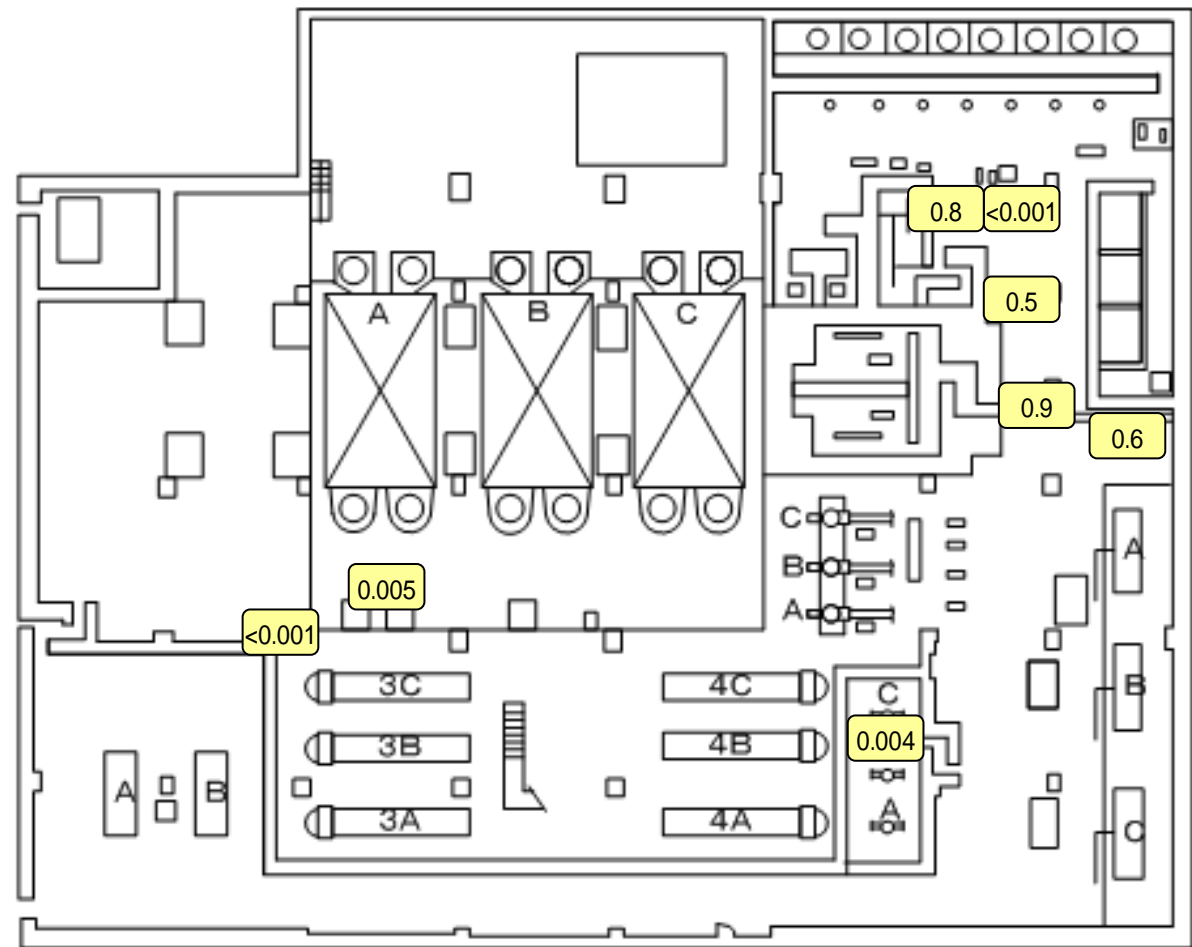

B1, T/B, Unit 5

Unit: mSv/h

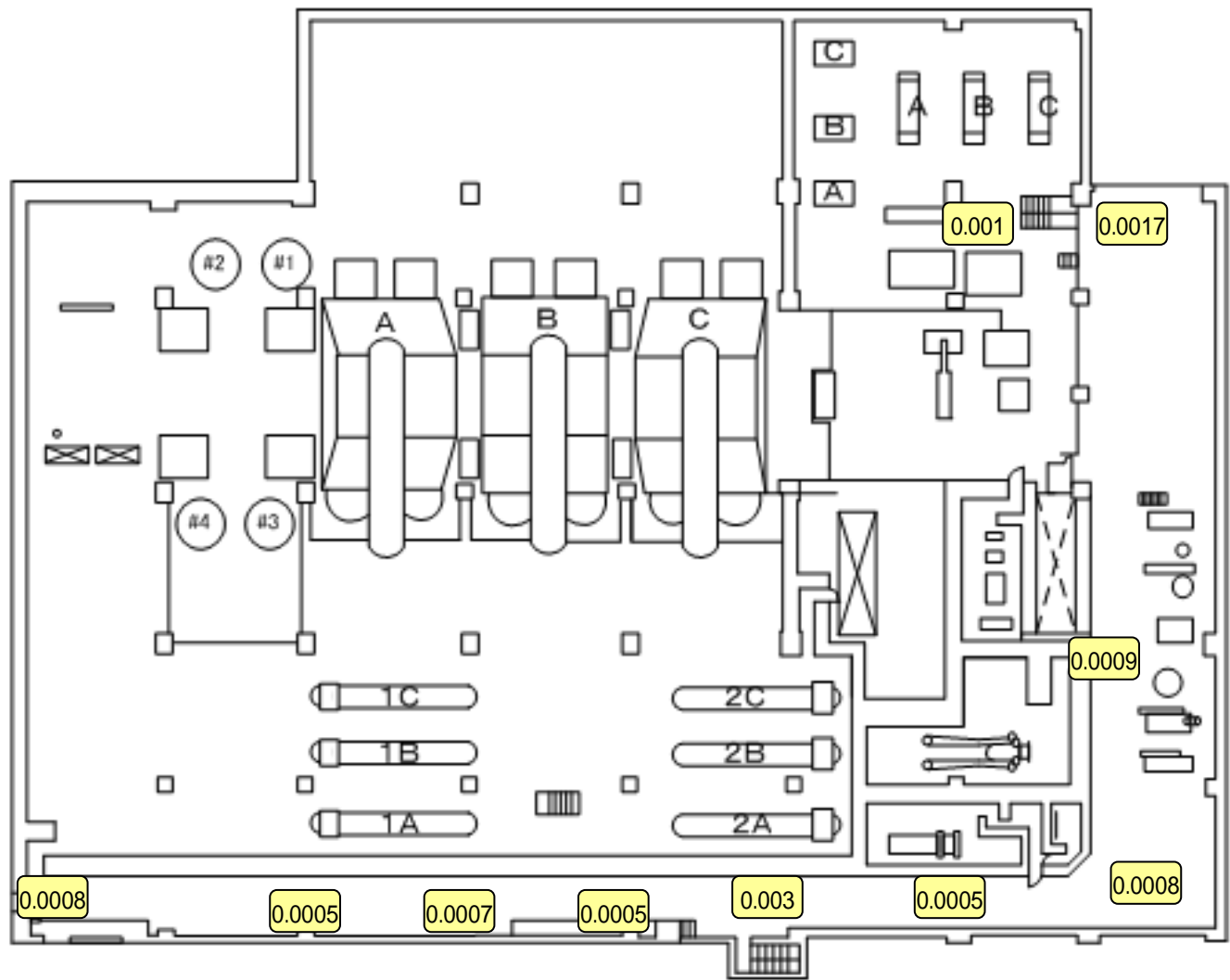

1FL, T/B, Unit 5

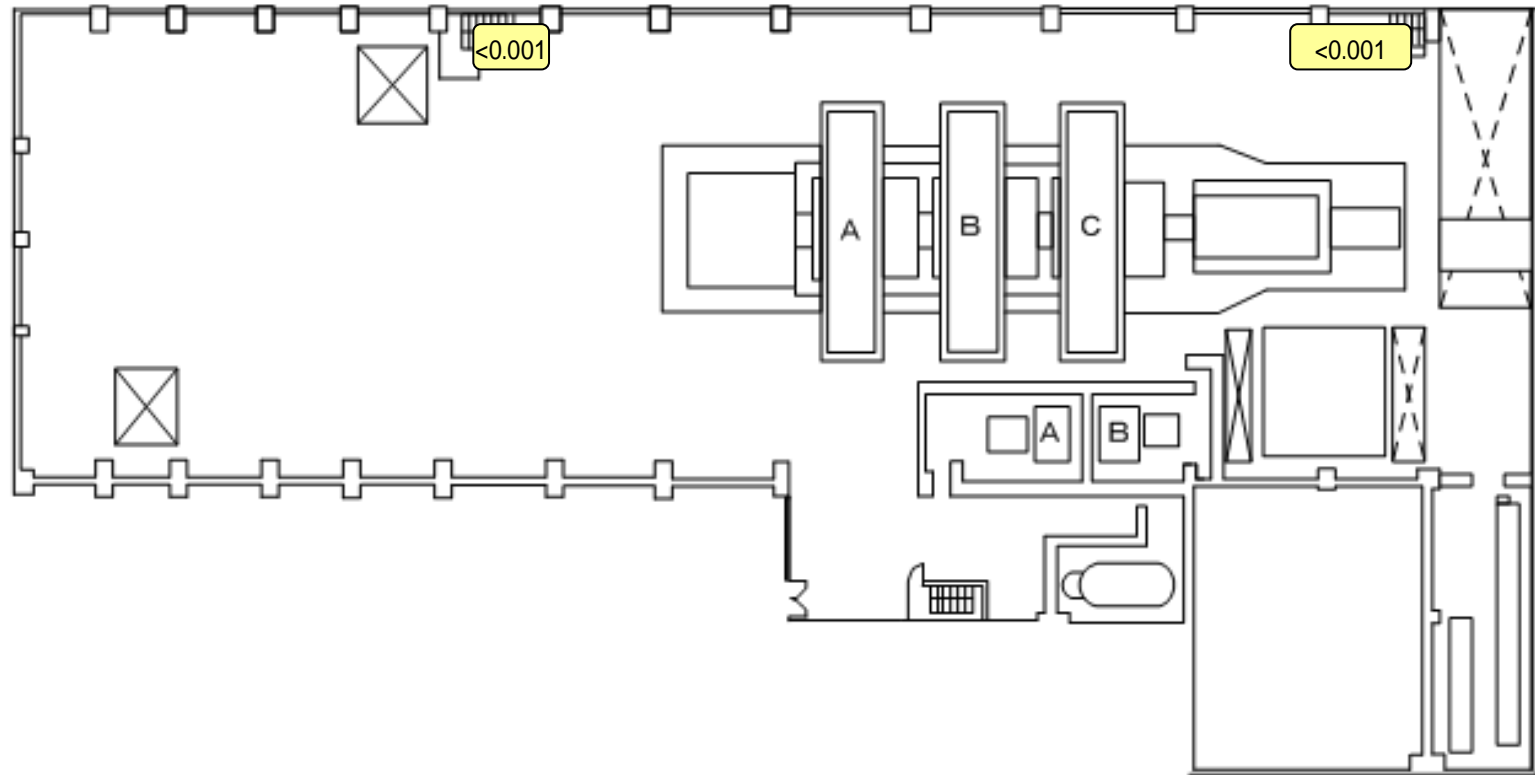

Unit: mSv/h

2FL, T/B, Unit 5

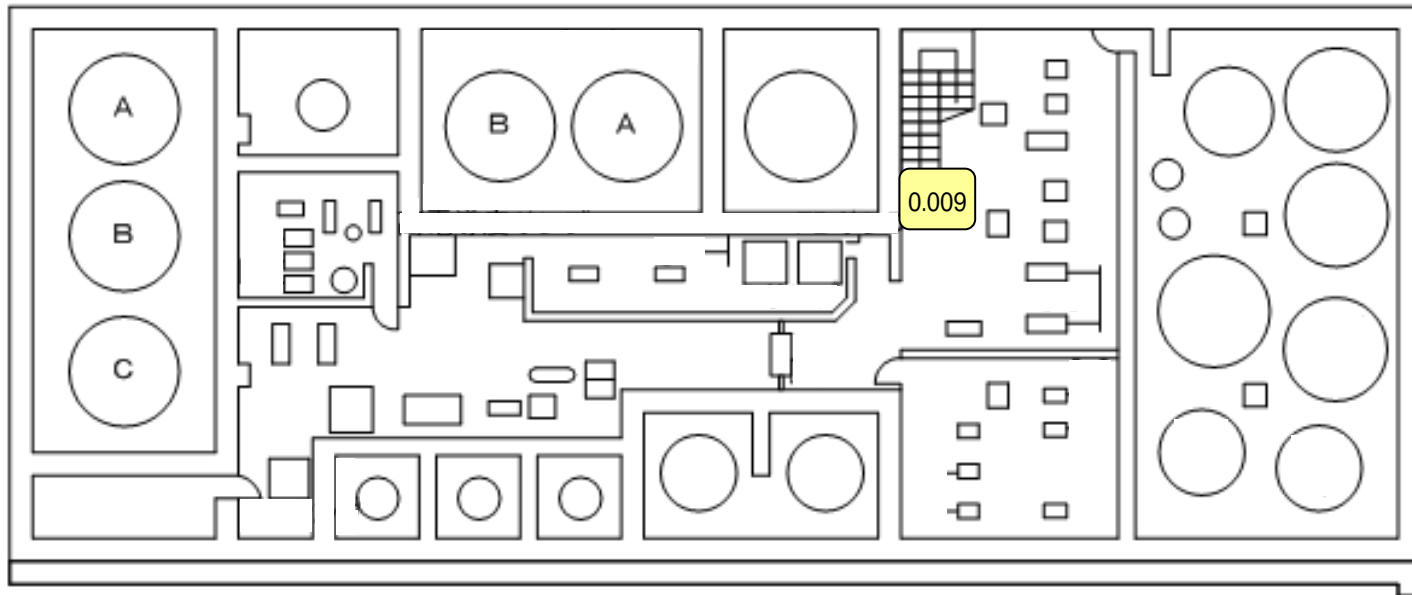

Unit: mSv/h

B1, Rad Waste Treatment Bldg, Unit 5

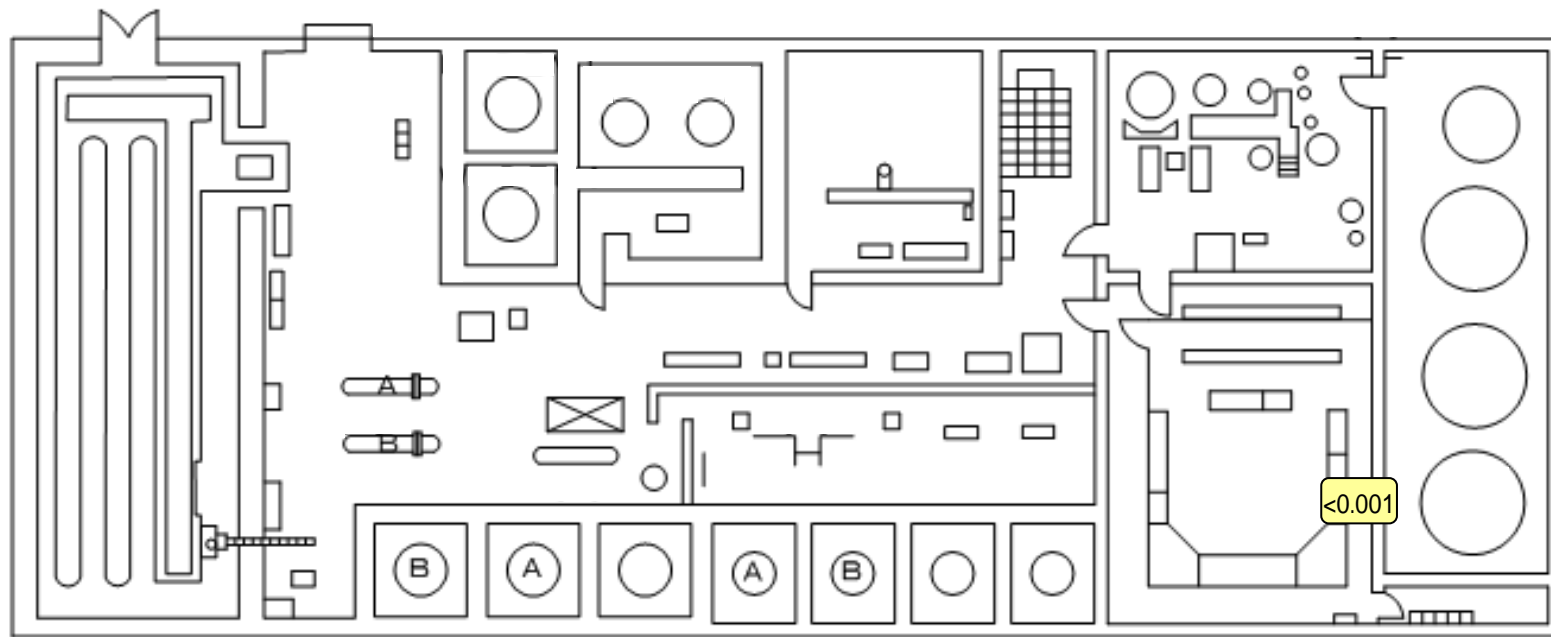

Unit: mSv/h

1FL, Rad Waste Treatment Bldg, Unit 5

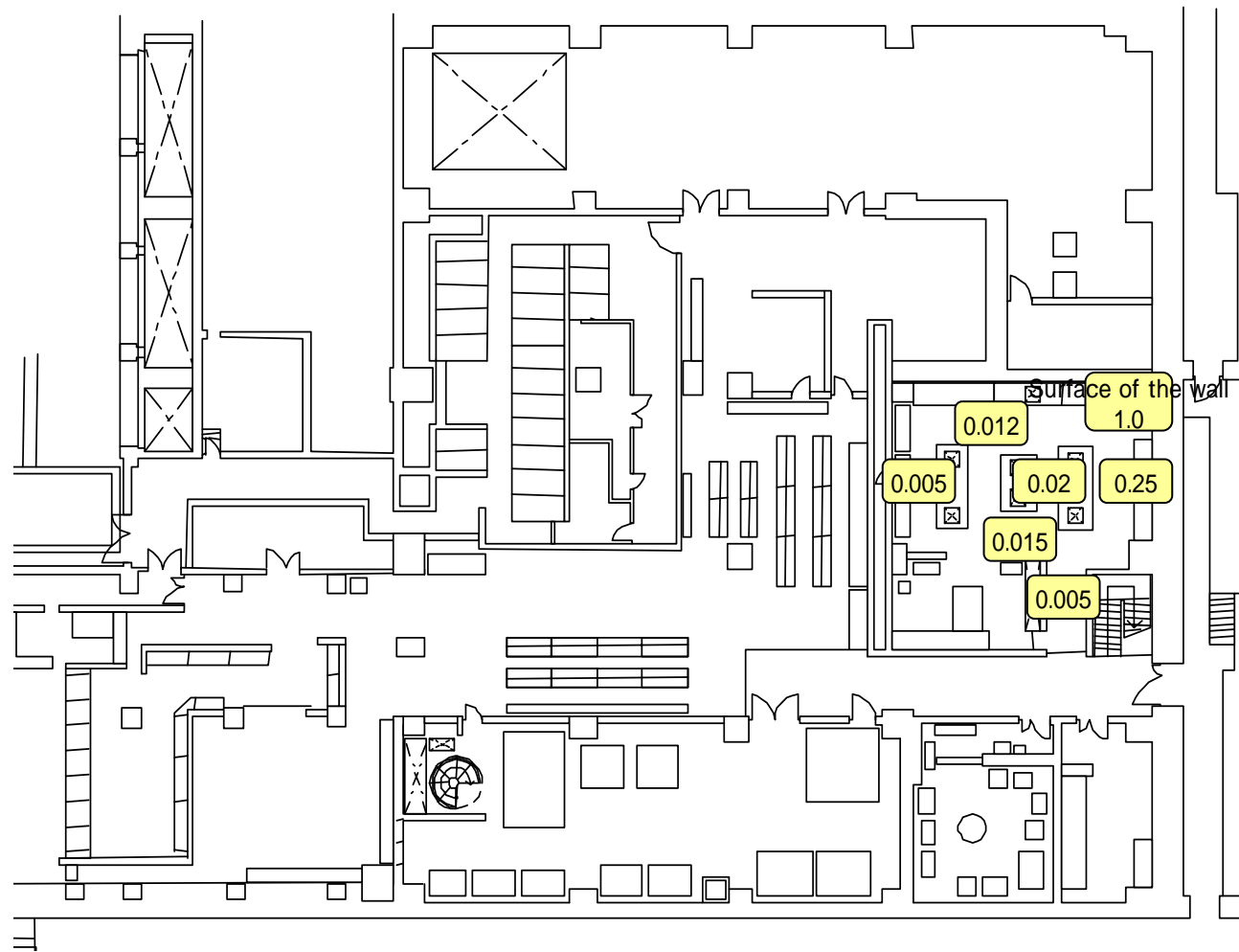

Unit: mSv/h

1FL, Service Bldg, Units 5 & 6

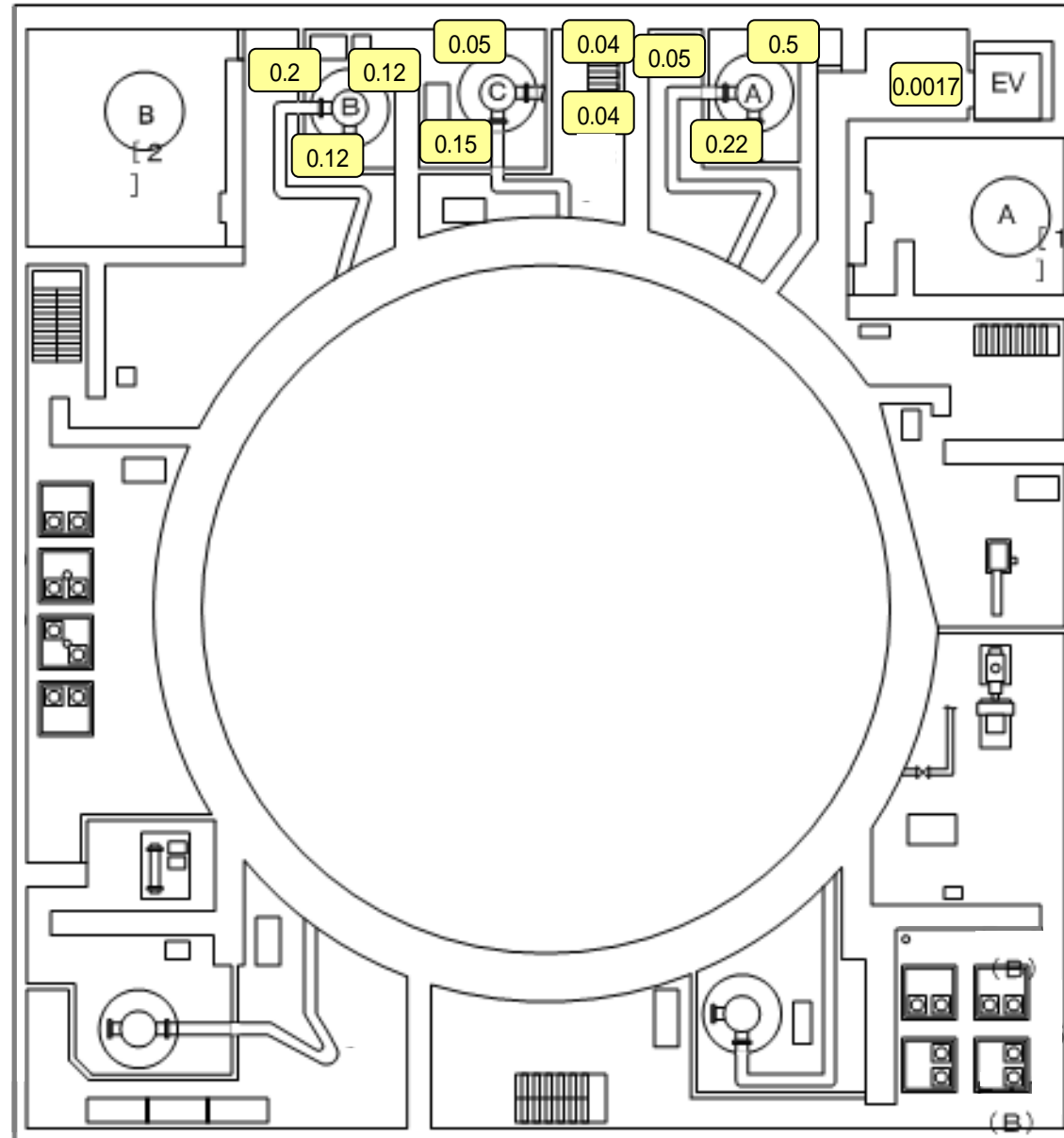

Unit: mSv/h

B2, R/B, Unit 6



Unit: mSv/h

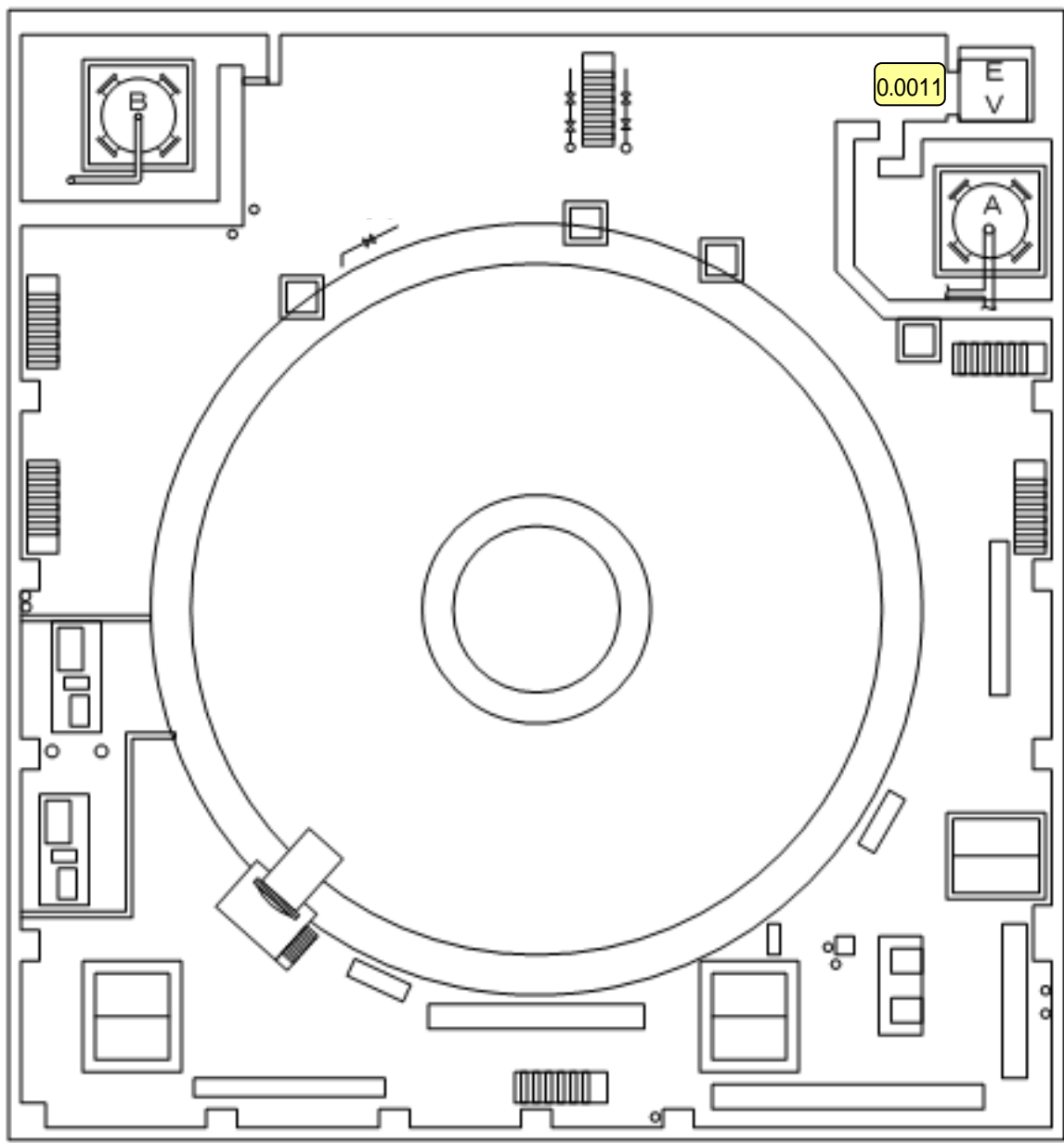

B1, R/B, Unit 6

Unit: mSv/h

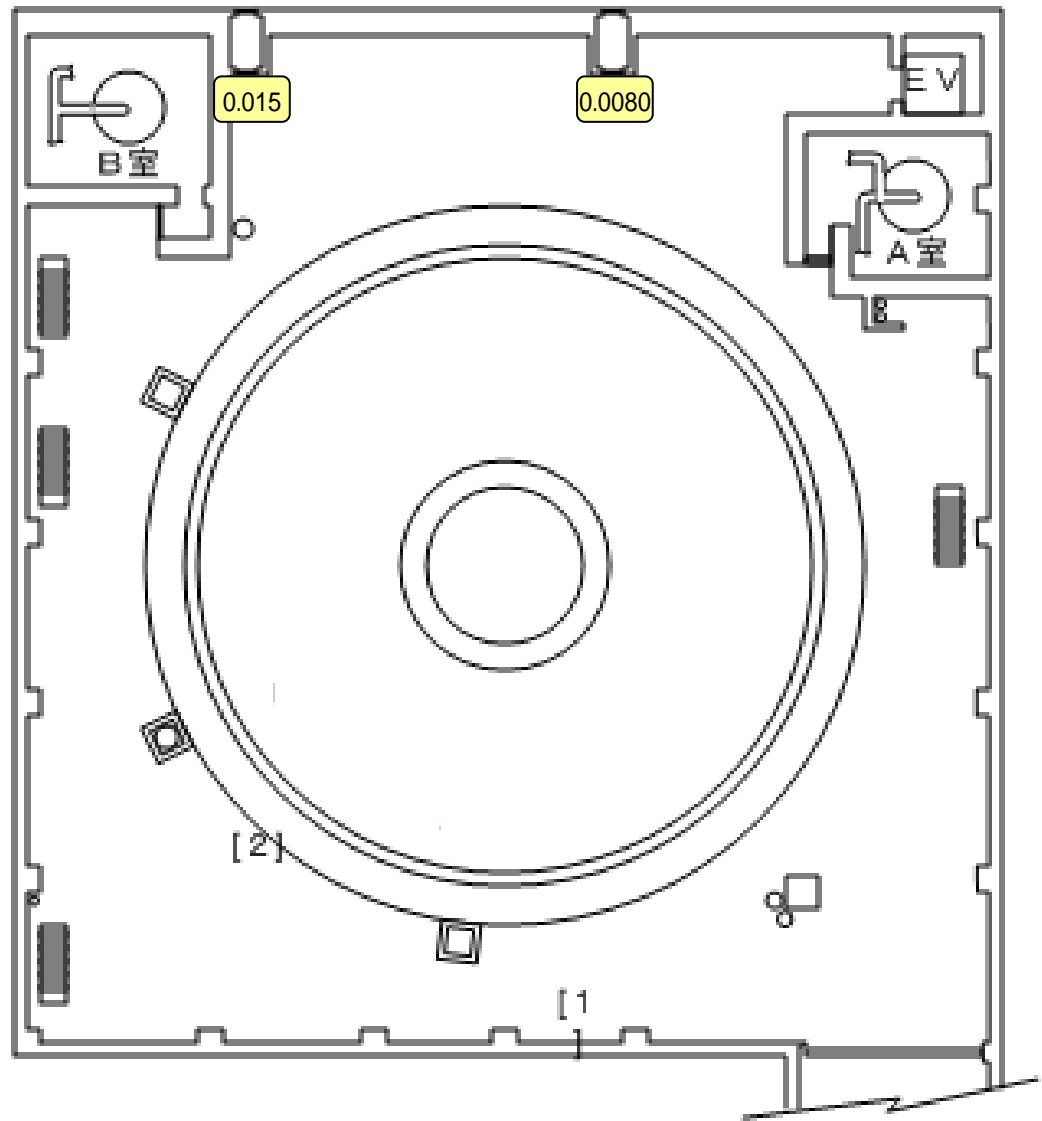

1FL, R/B, Unit 6

Unit: mSv/h

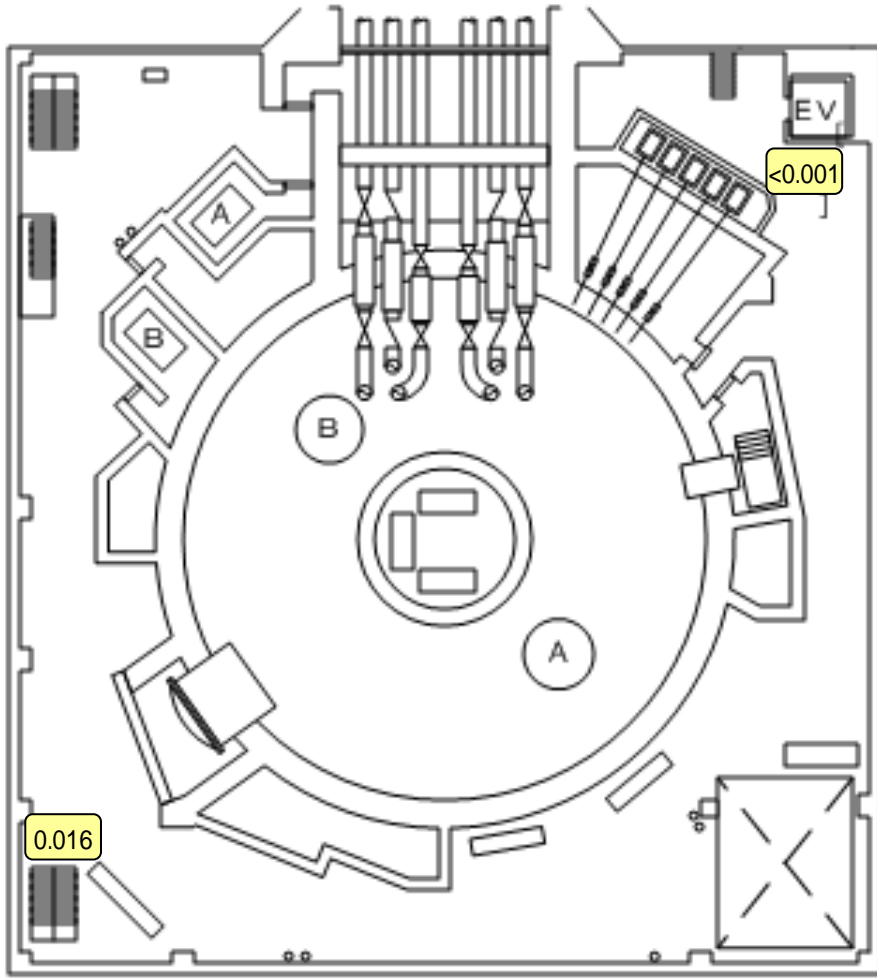

2FL, R/B, Unit 6

Unit: mSv/h

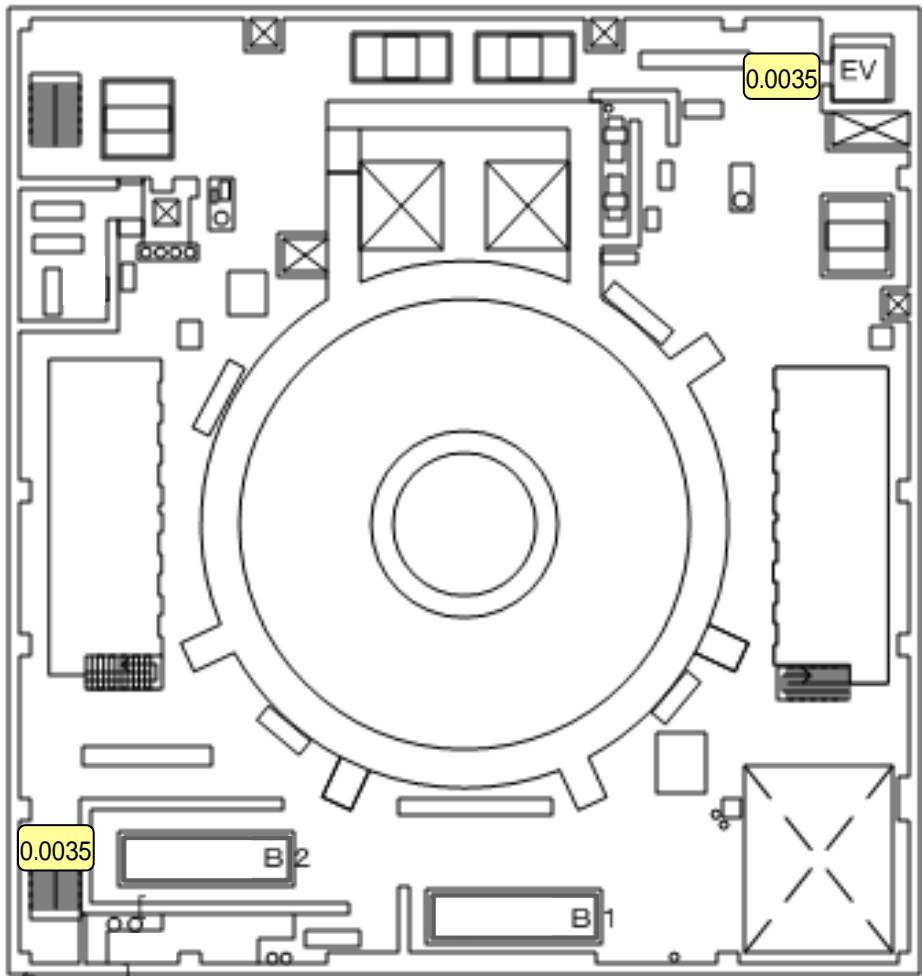

3FL, R/B, Unit 6

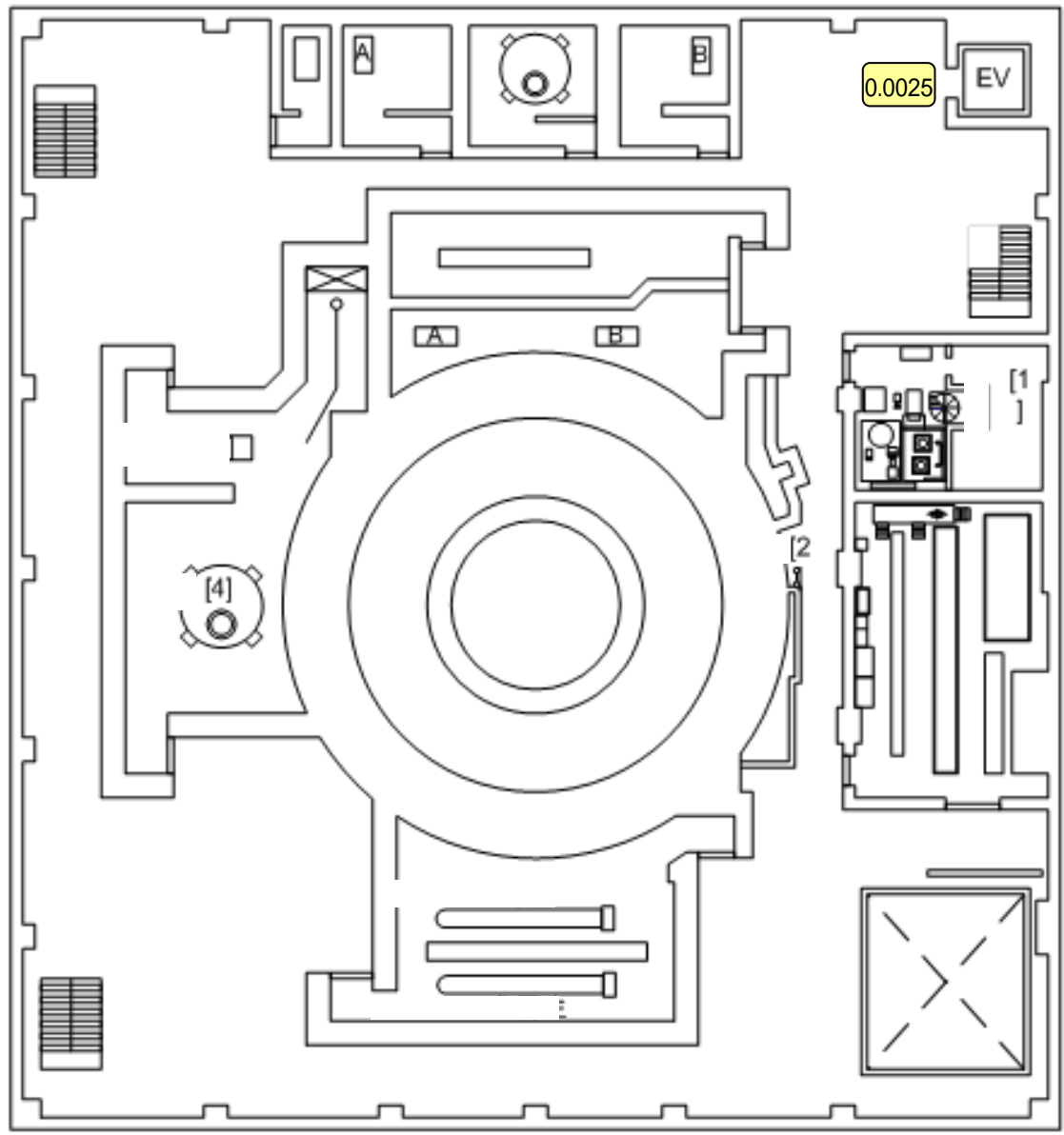

Unit: mSv/h

4FL, R/B, Unit 6

Unit: mSv/h

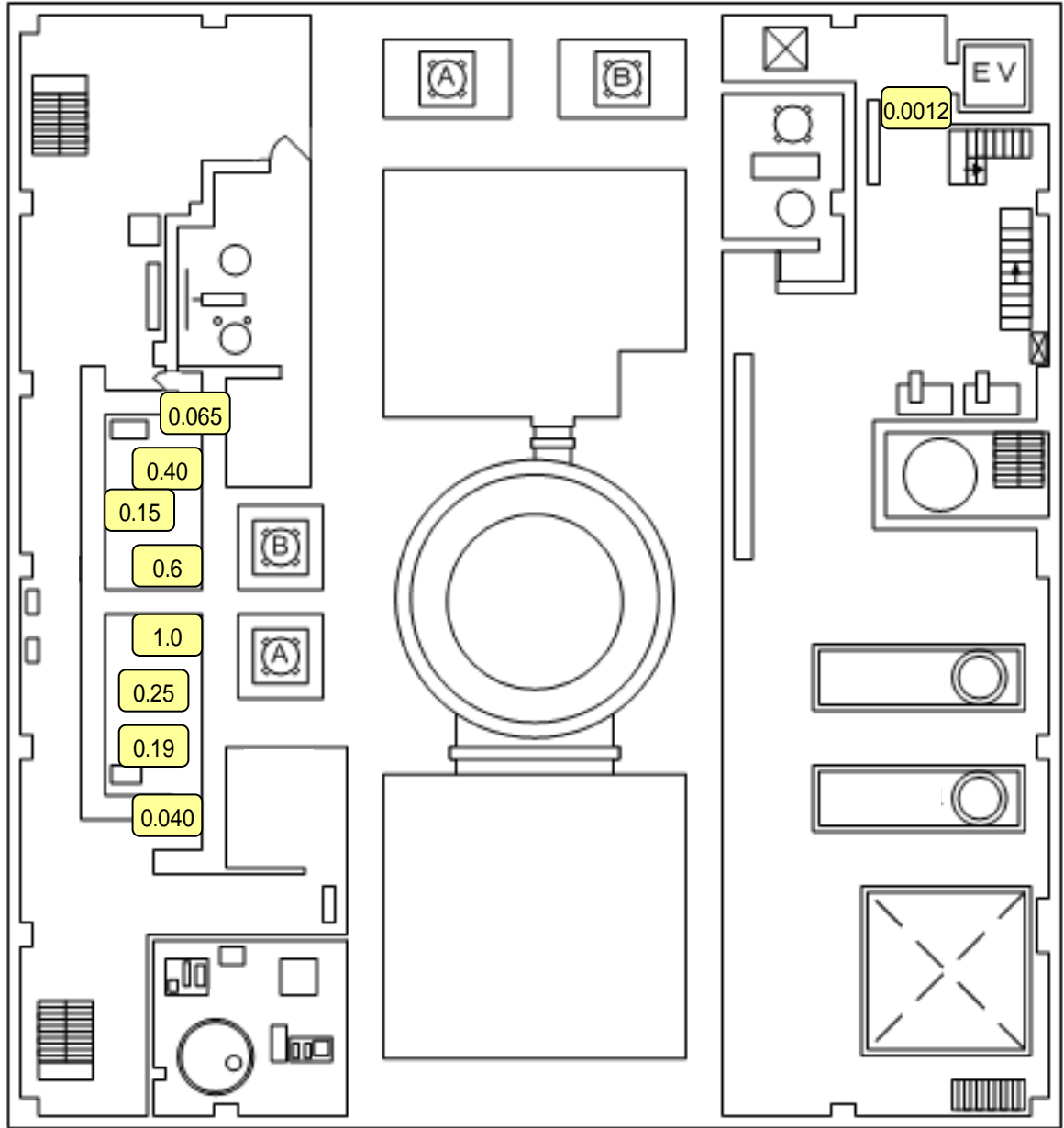

5FL, R/B, Unit 6

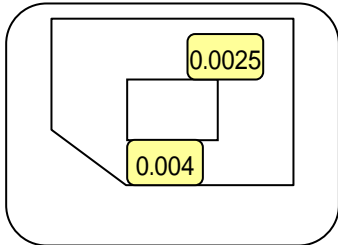
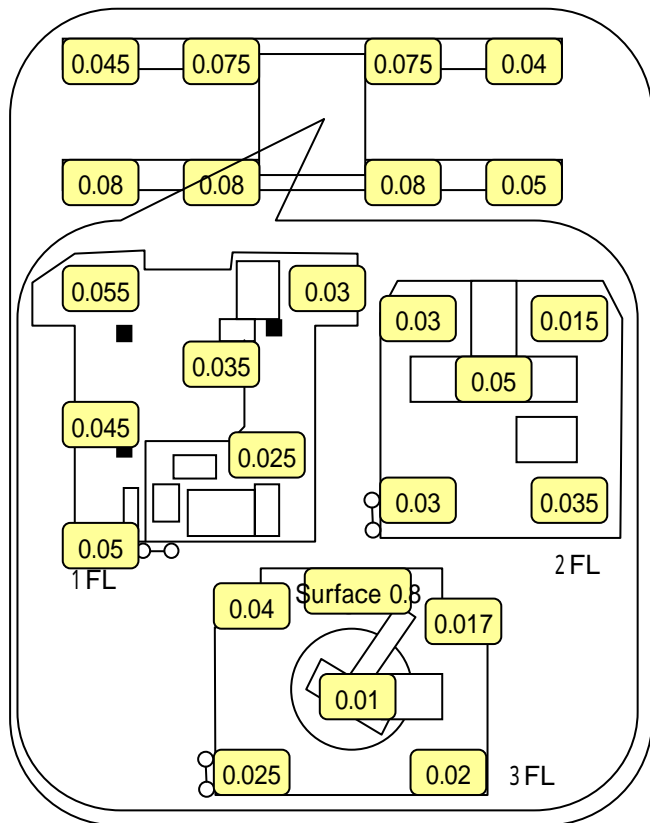

Unit: mSv/h

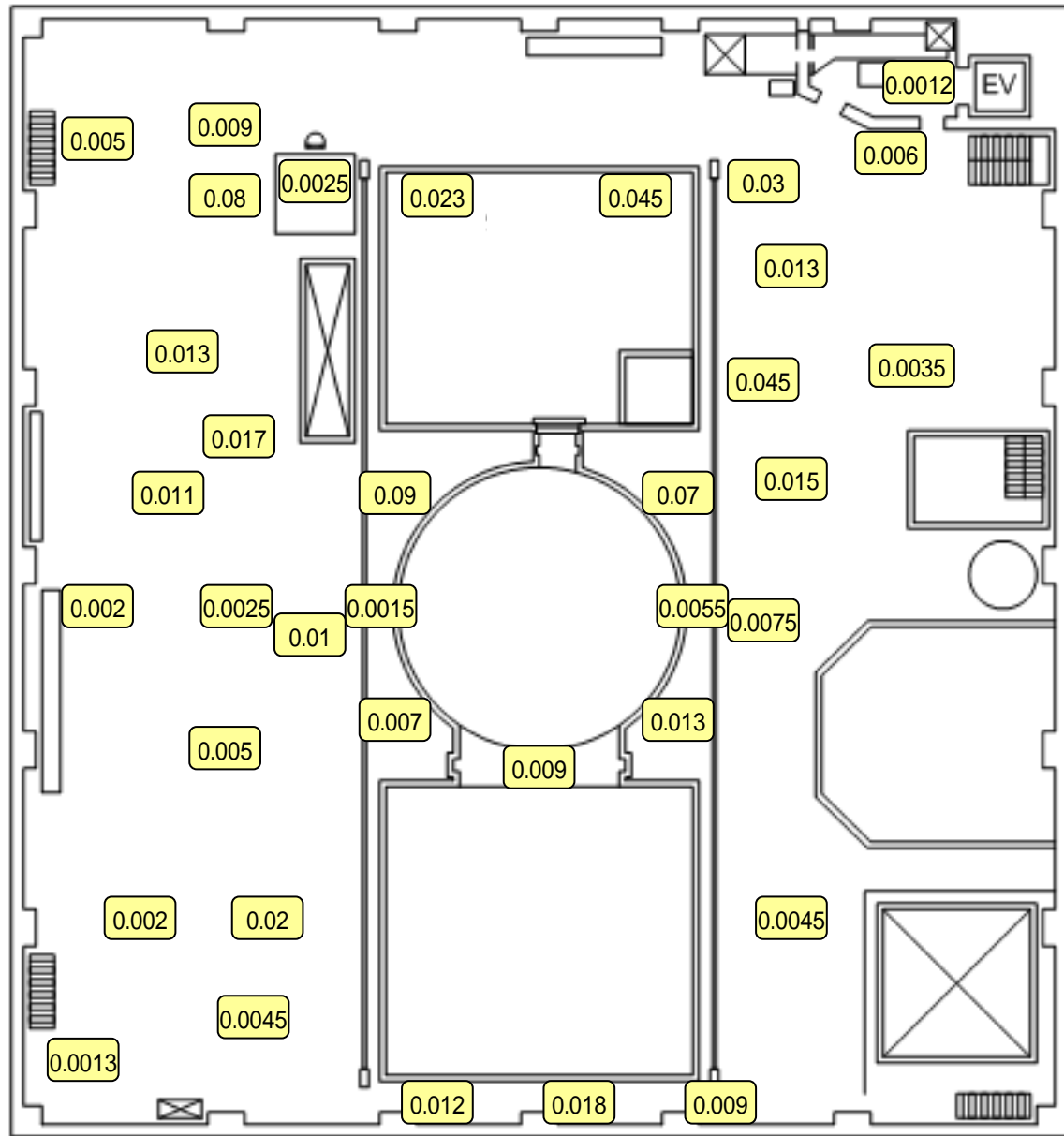

6FL, R/B, Unit 6

Unit: mSv/h

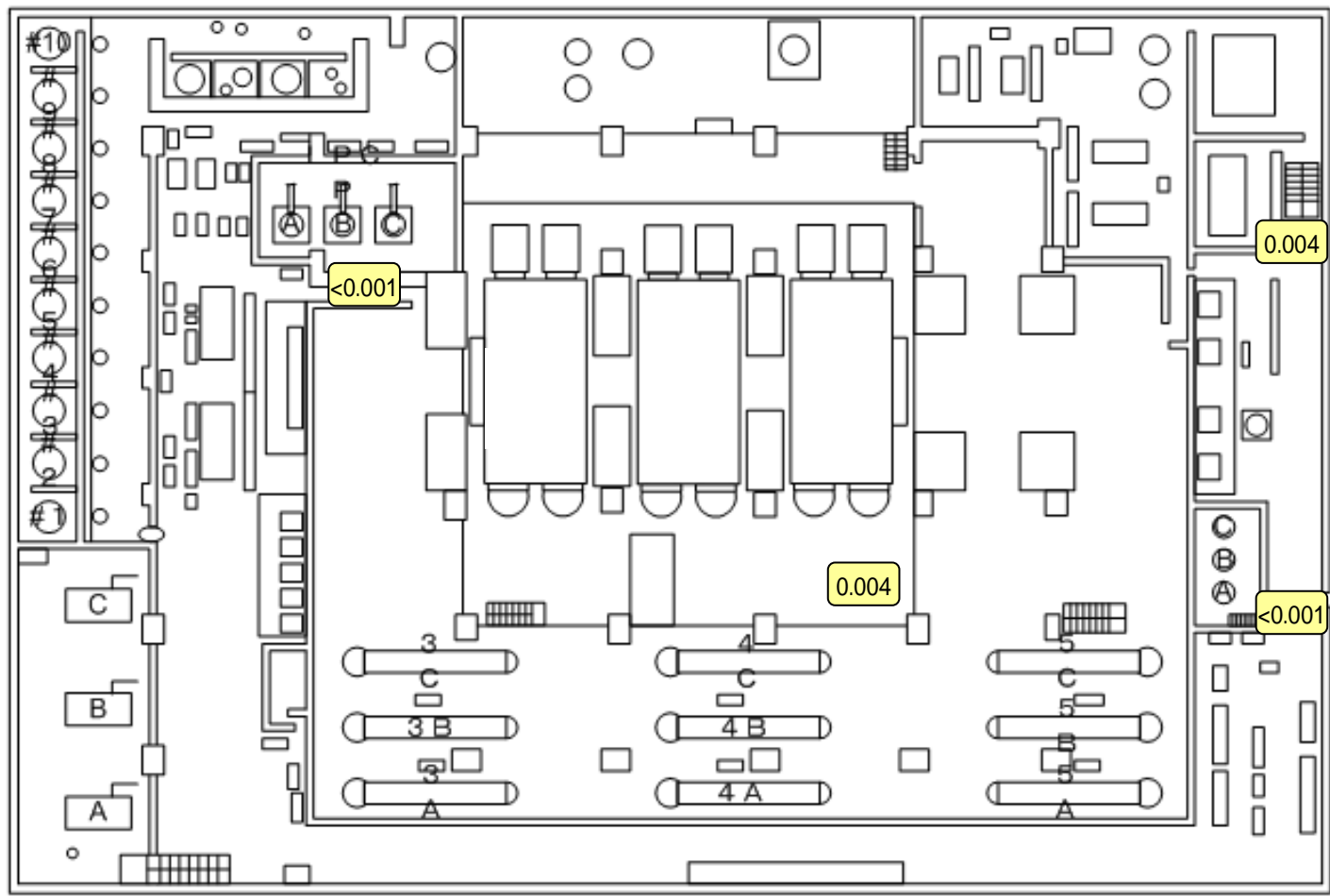

B1, T/B, Unit 6



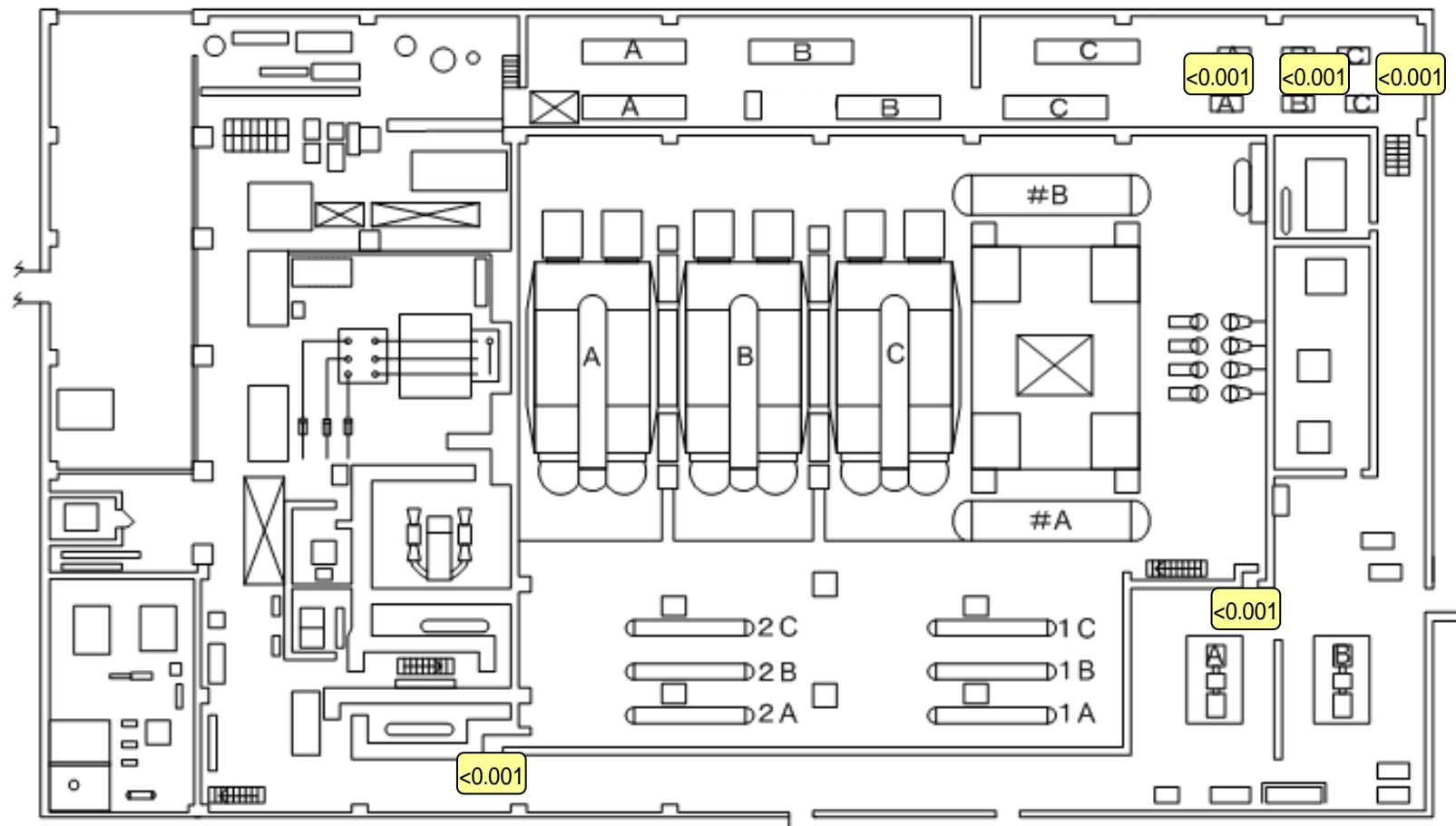

Unit: mSv/h

1FL, T/B, Unit 6

Unit: mSv/h

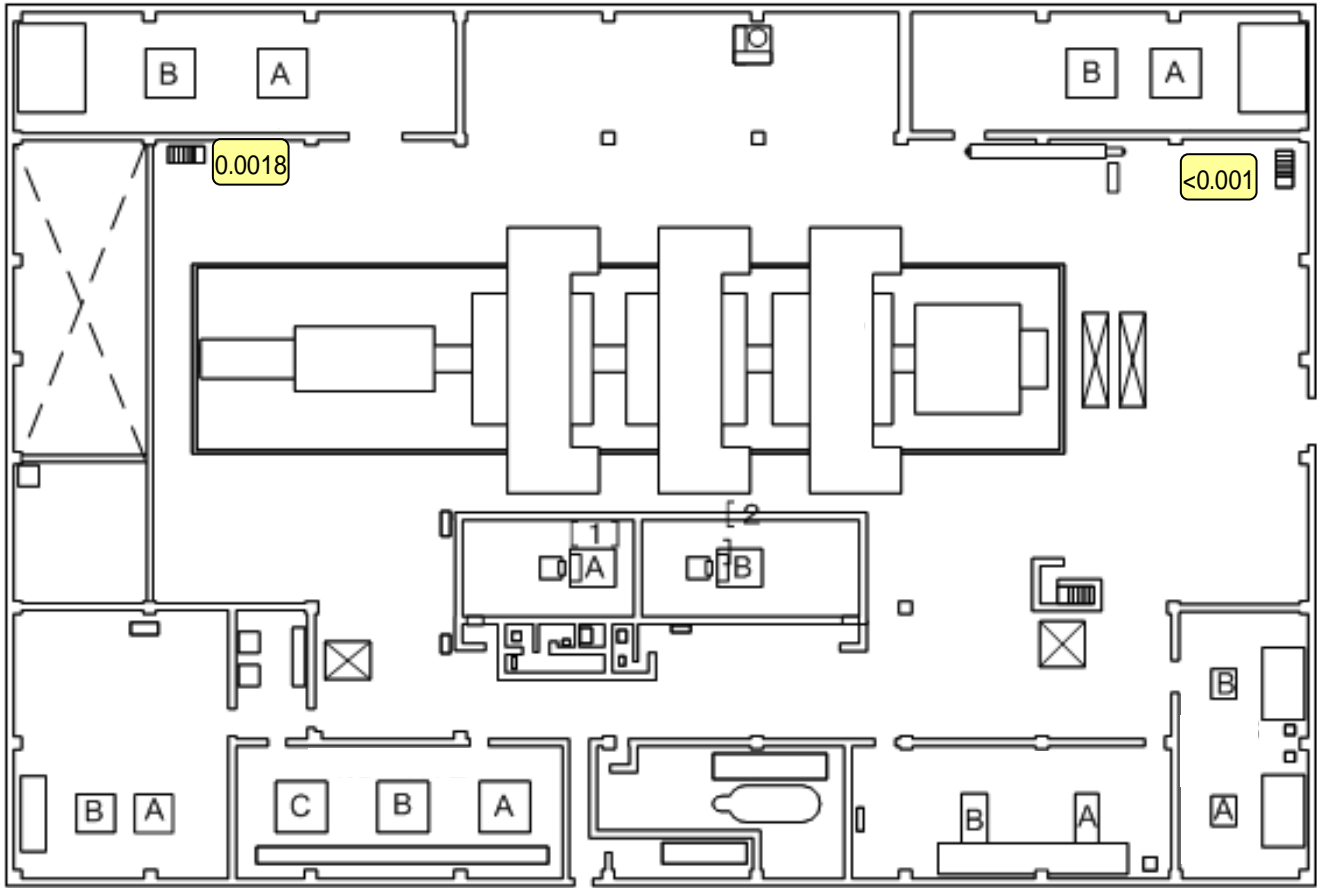

2FL, T/B, Unit 6

Unit: mSv/h

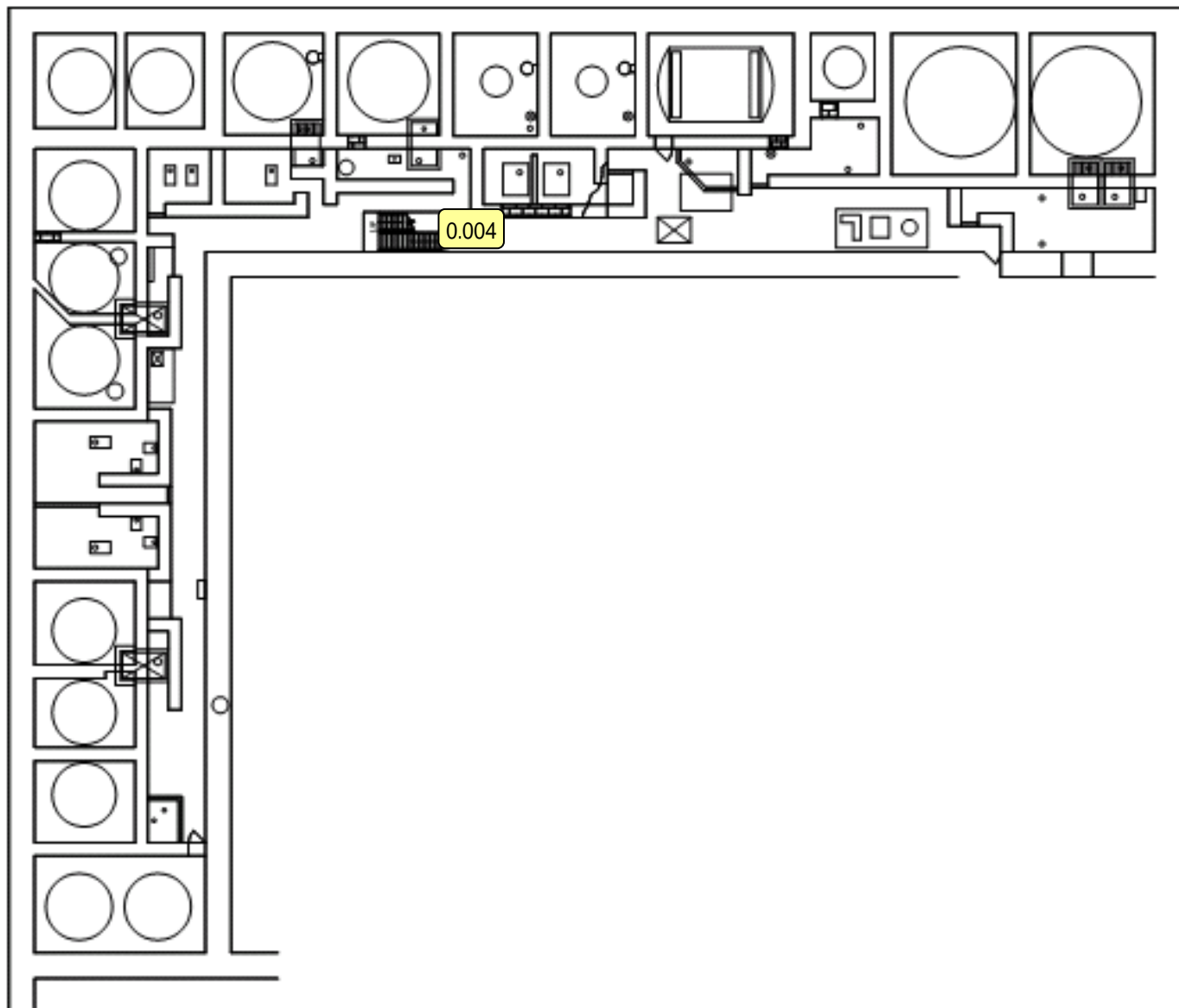

B2, Rad Waste Treatment Bldg, Unit 6

Bearing Area

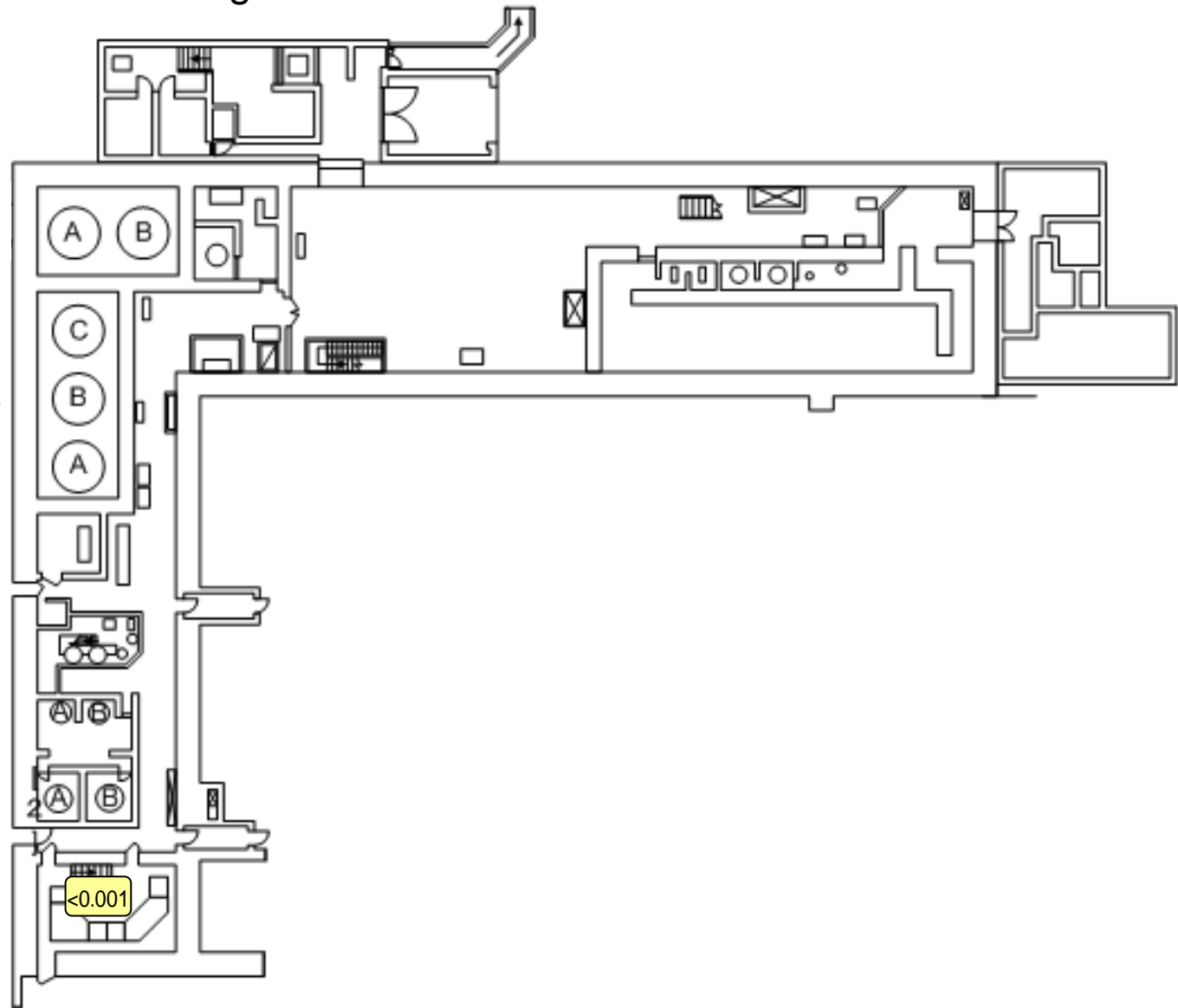

Unit: mSv/h

1FL, Rad Waste Treatment Bldg, Unit 6



1FL, Process Main Bldg



Unit: mSv/h

2FL, Process Main Bldg

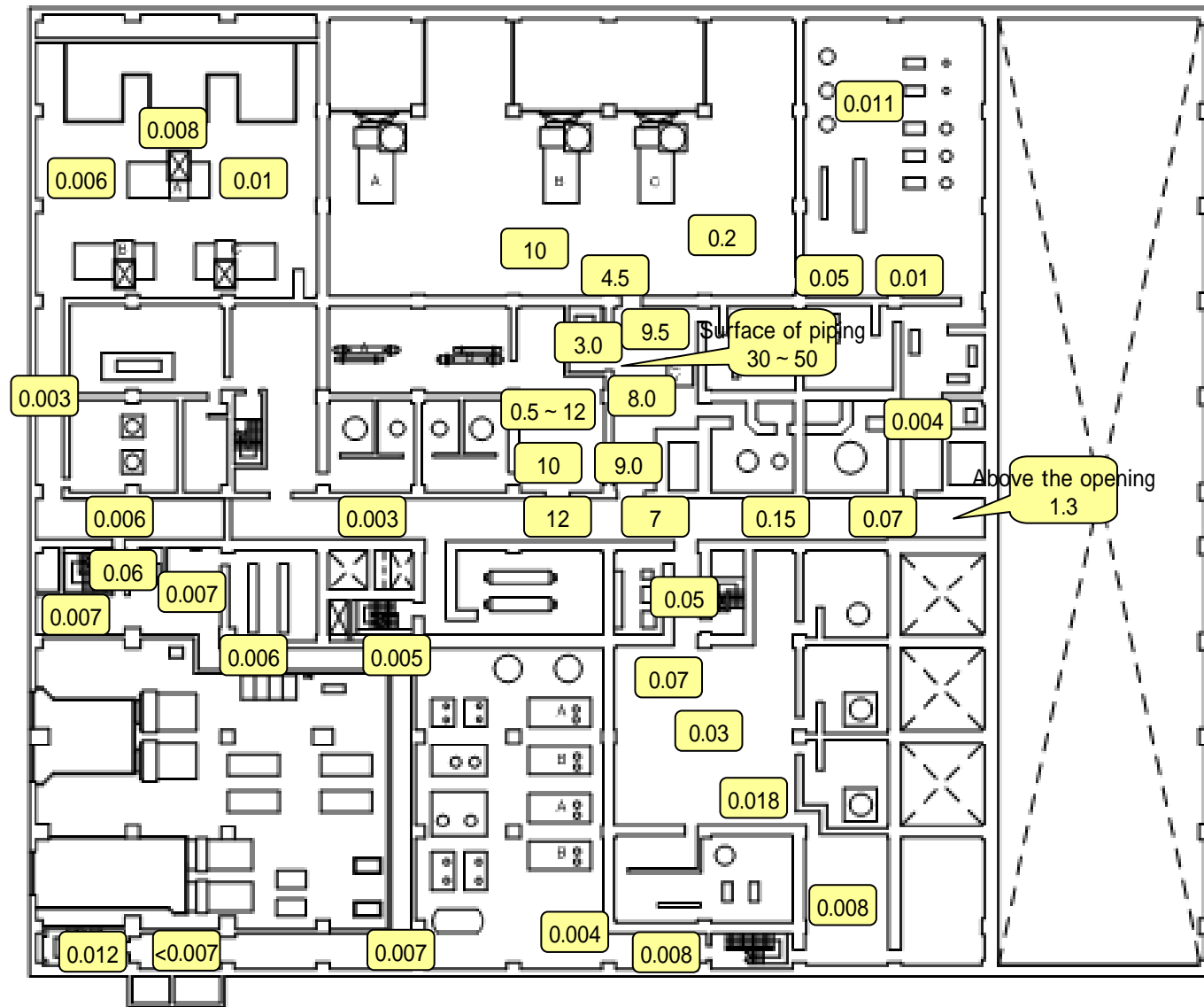

3FL, Process Main Bldg

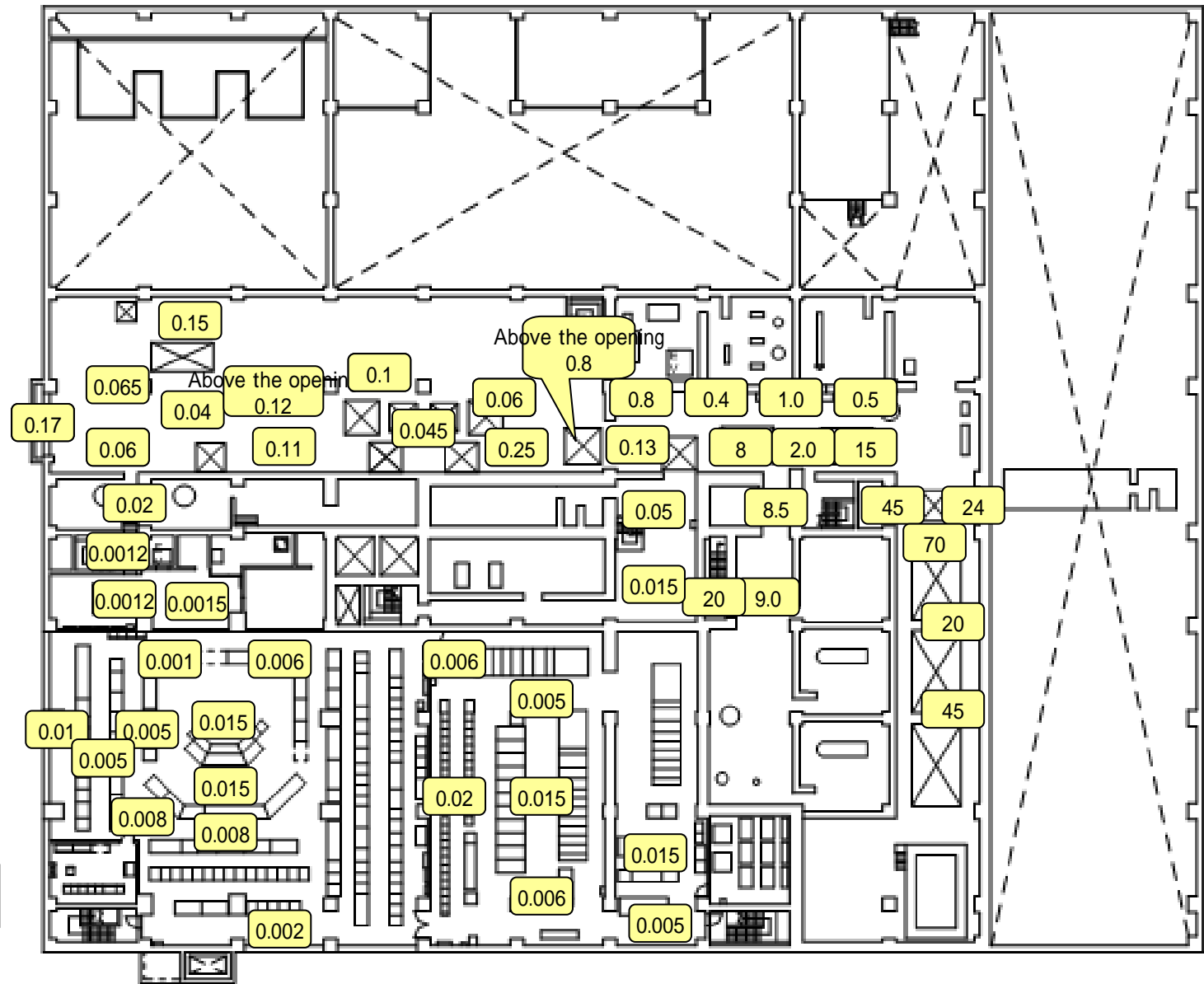

4FL, Process Main Bldg



Unit: mSv/h

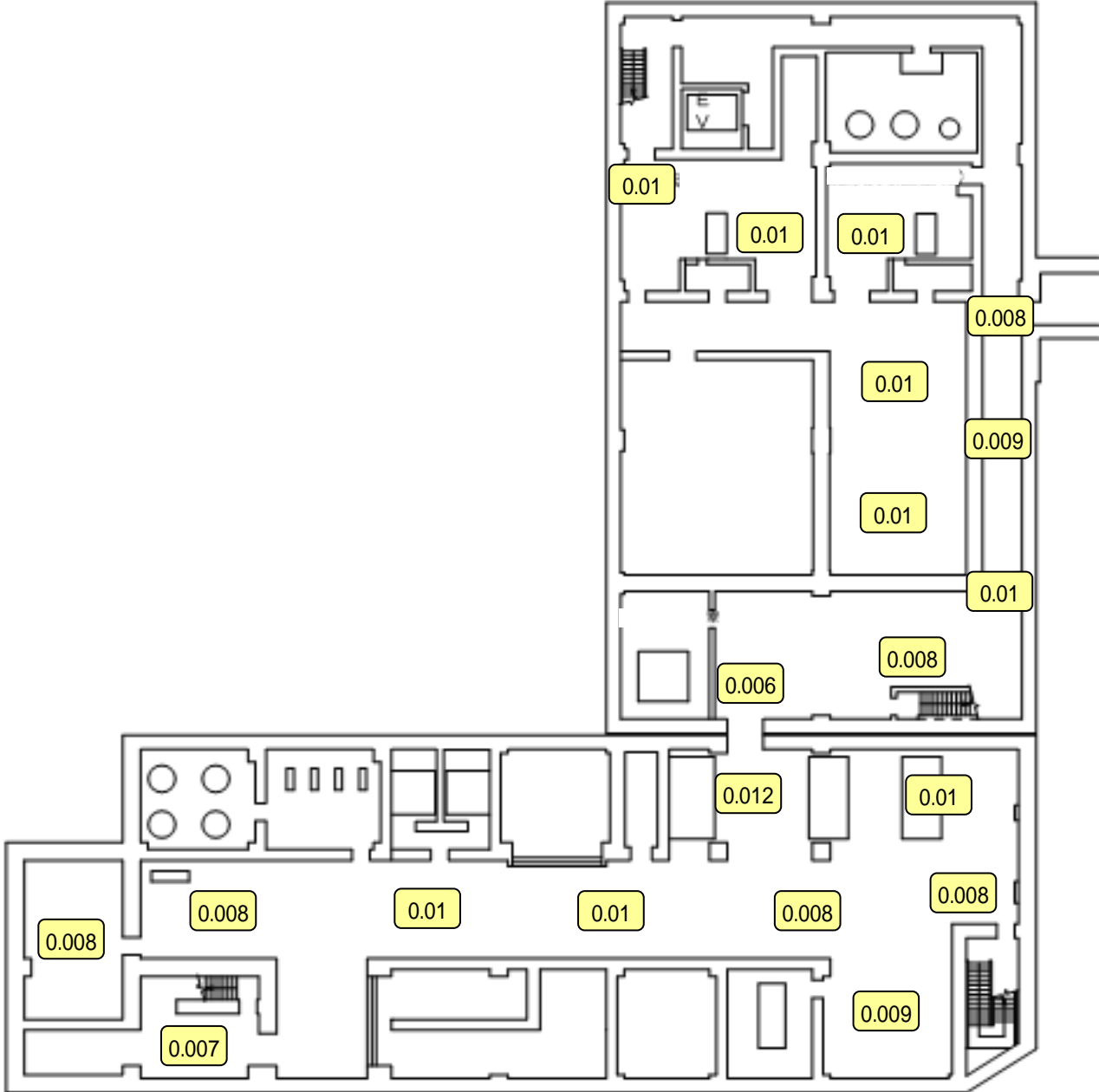

B1, Incineration Workshop Bldg

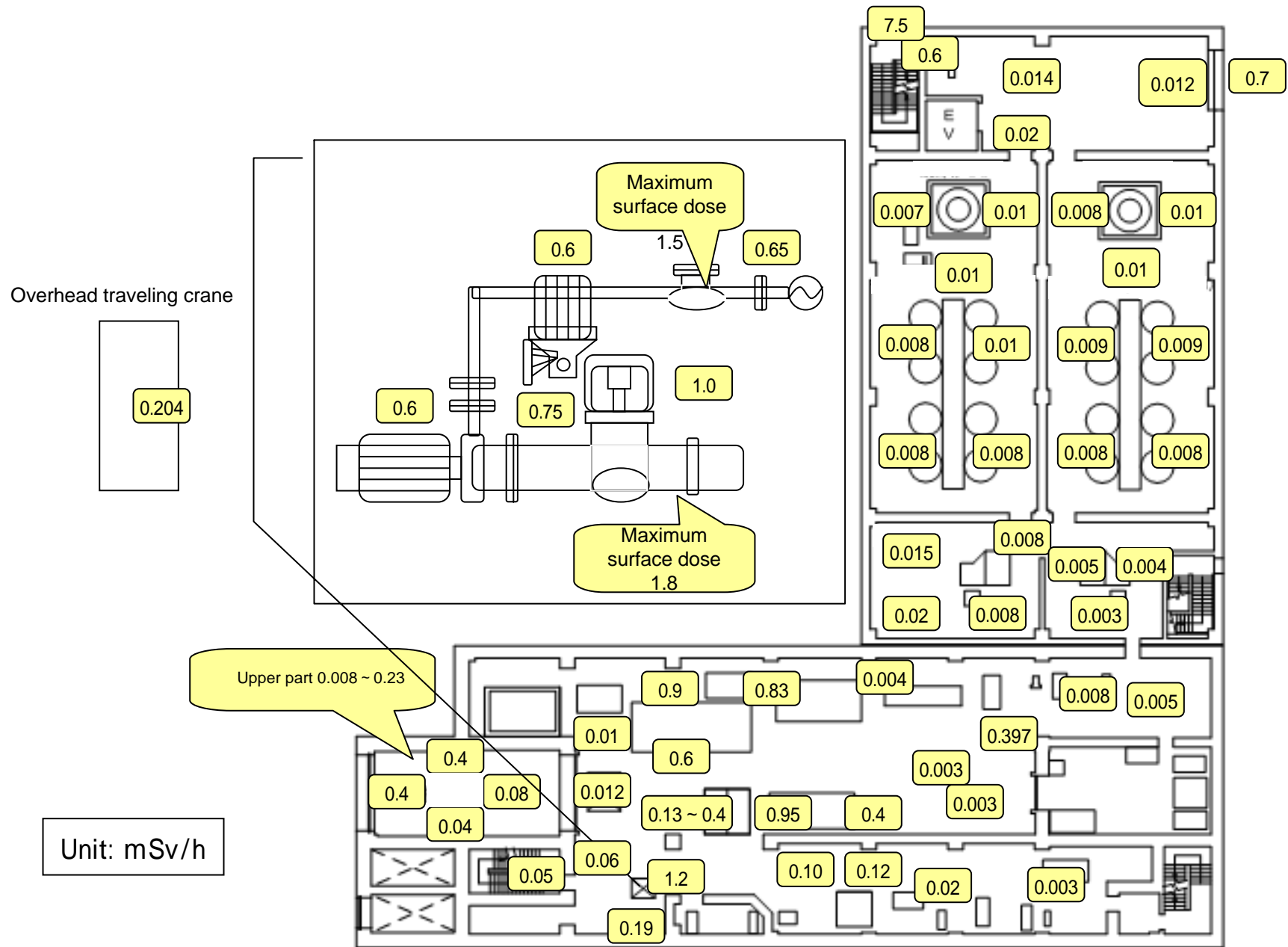

1FL, Incineration Workshop Bldg

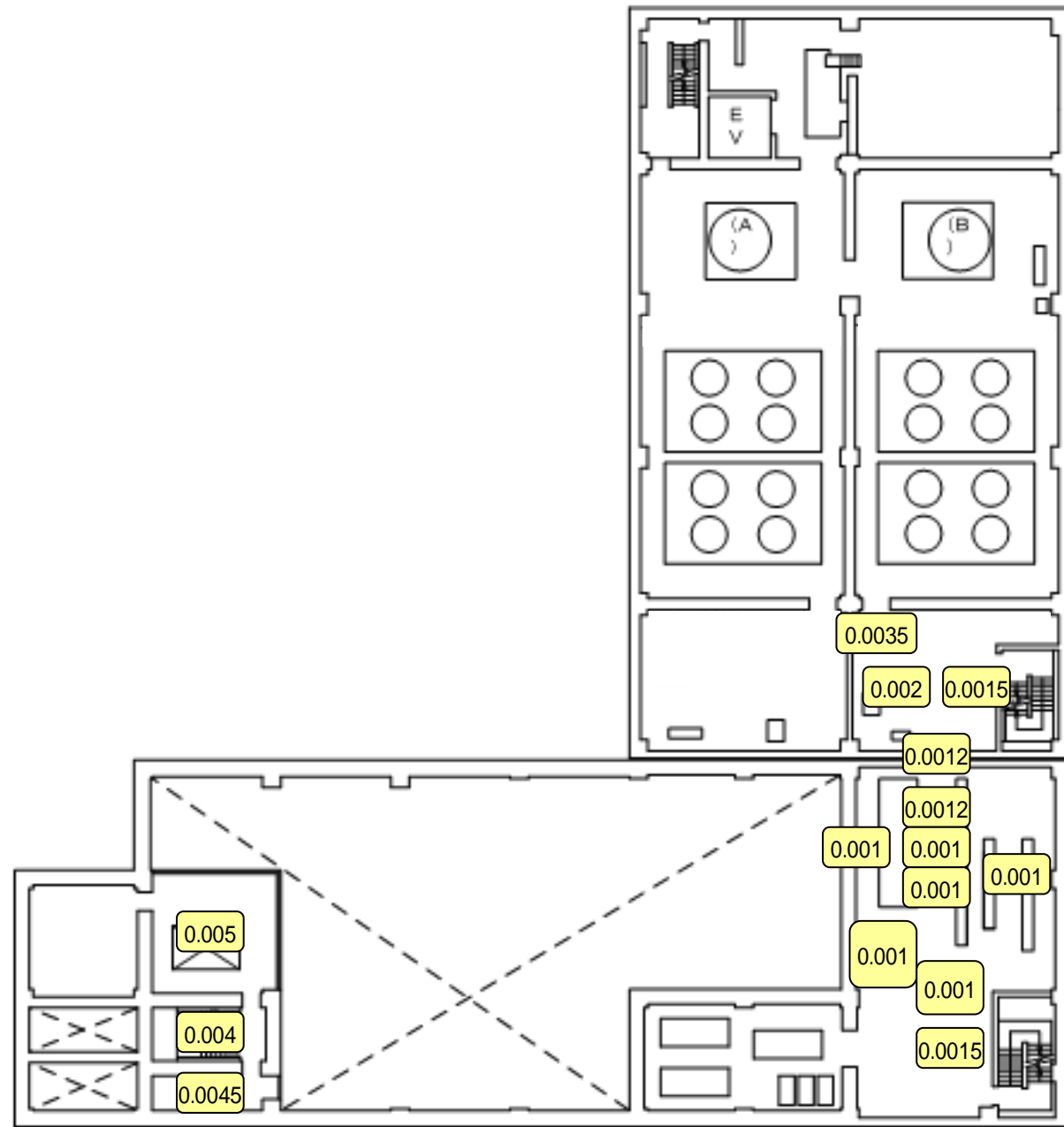

Unit: mSv/h

2FL, Incineration Workshop Bldg

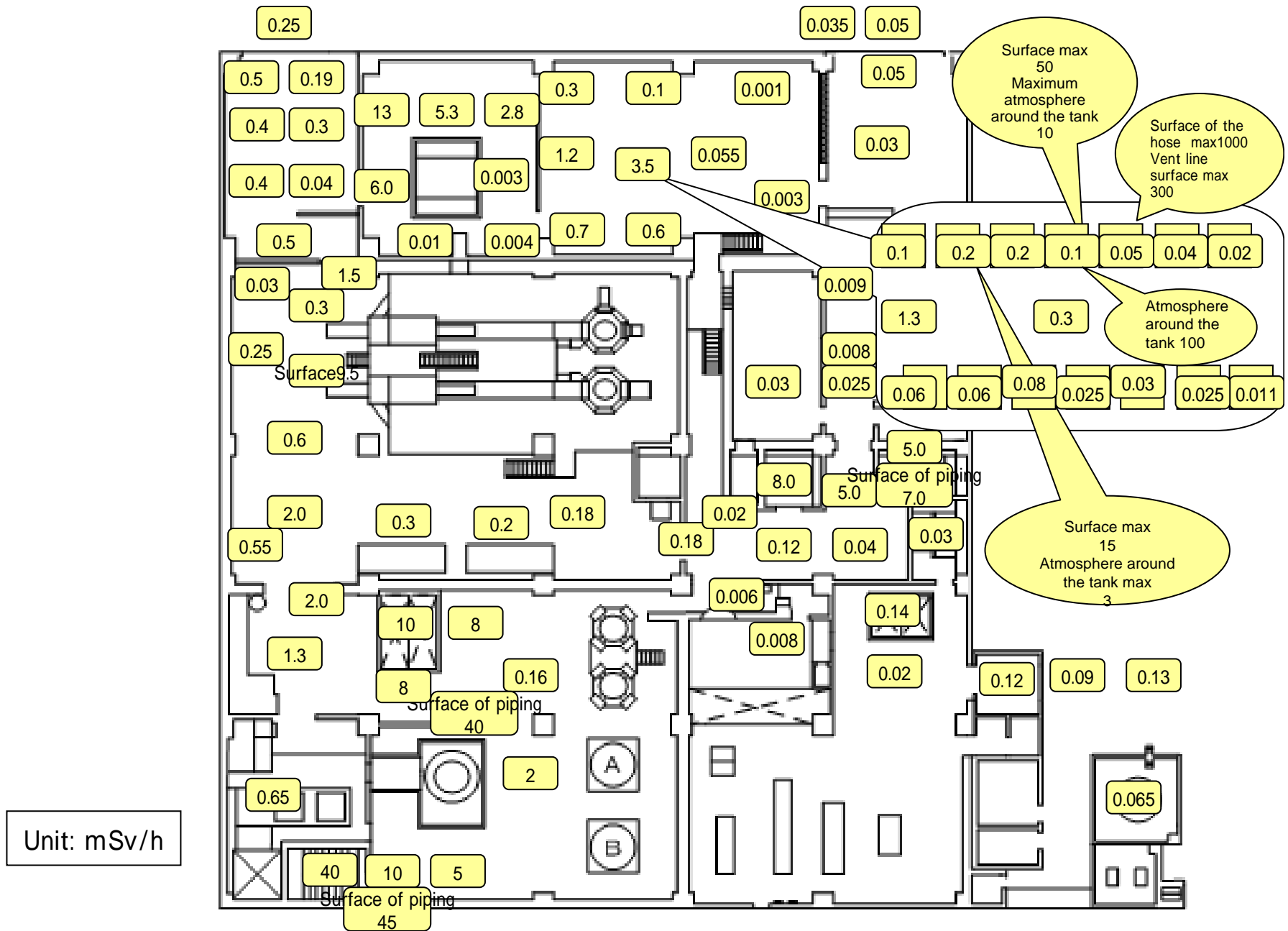

1FL, Misc Solid Waste Volume Reduction Bldg



2FL, Misc Solid Waste Volume Reduction Bldg

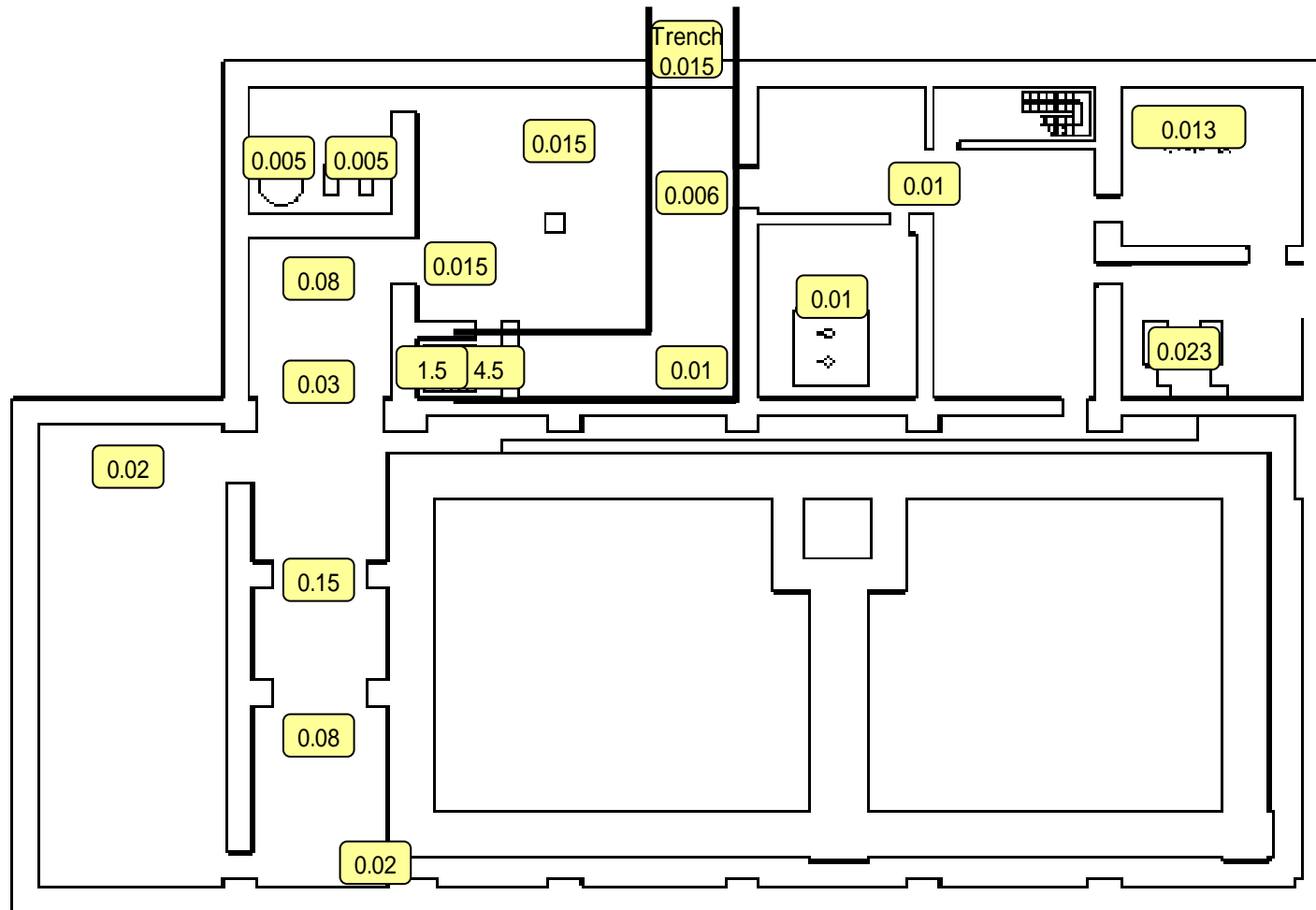

Unit: mSv/h

B1, Site Bunker Bldg

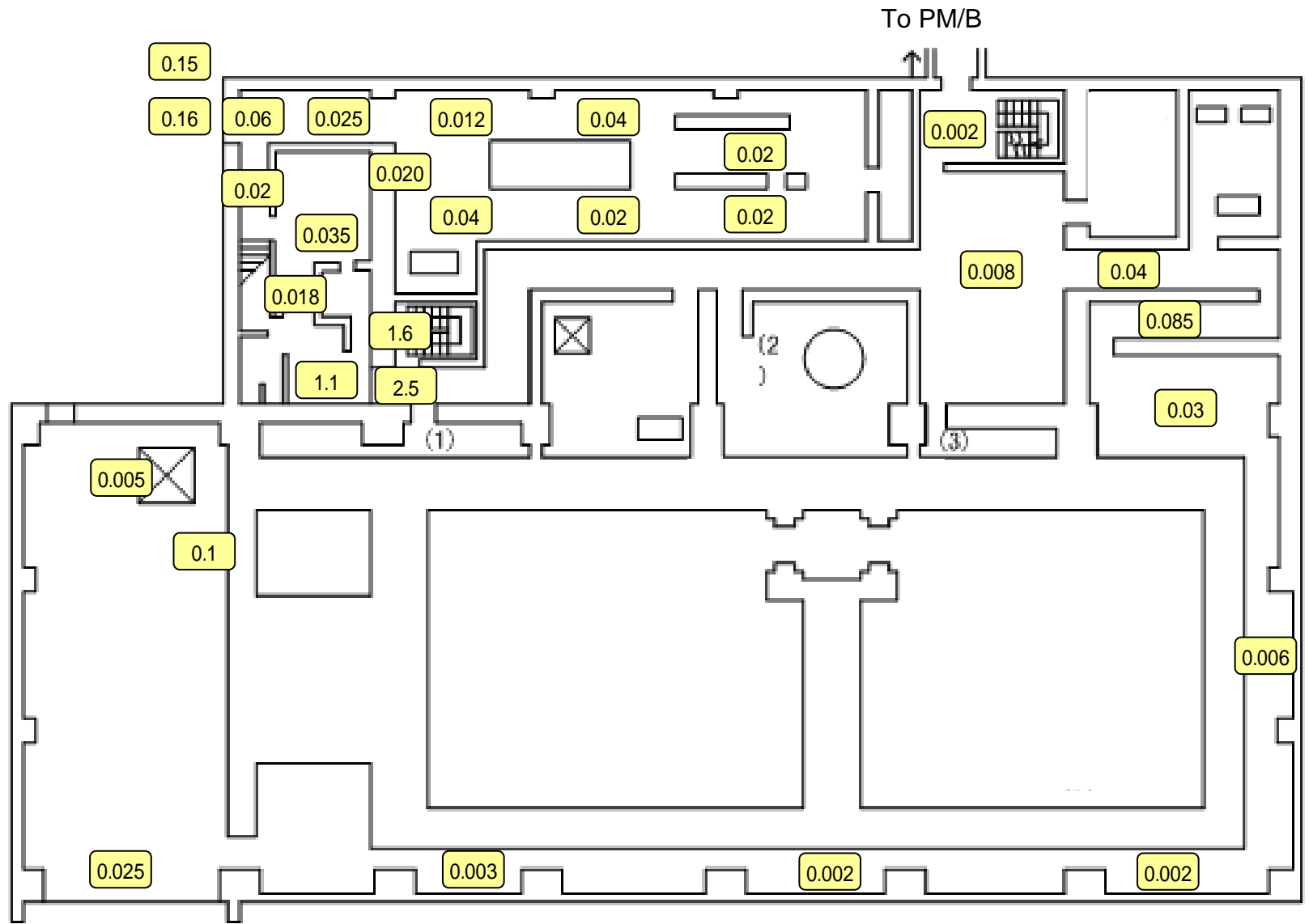

Unit: mSv/h

1FL, Site Bunker Bldg

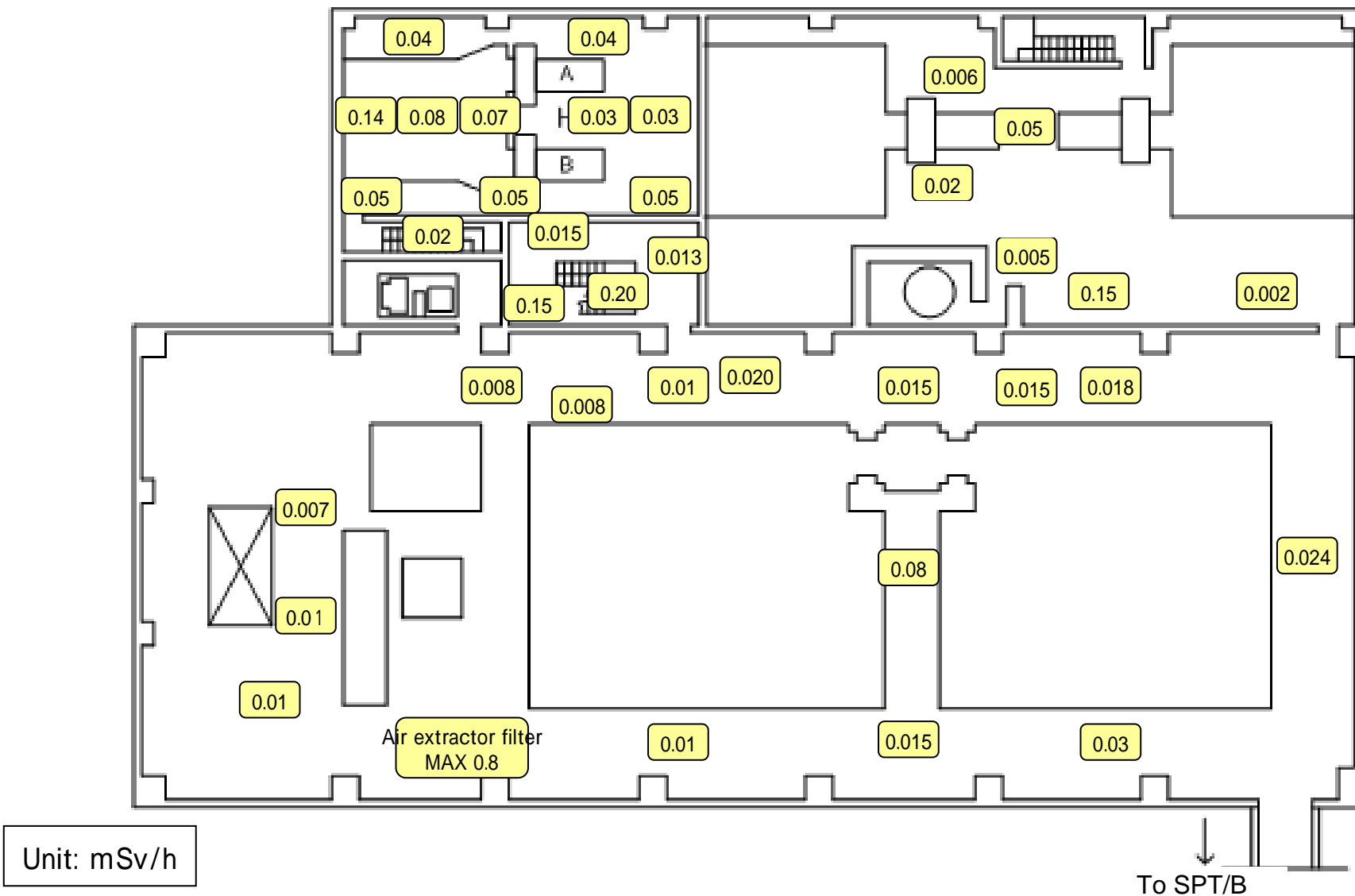

2FL, Site Bunker Bldg



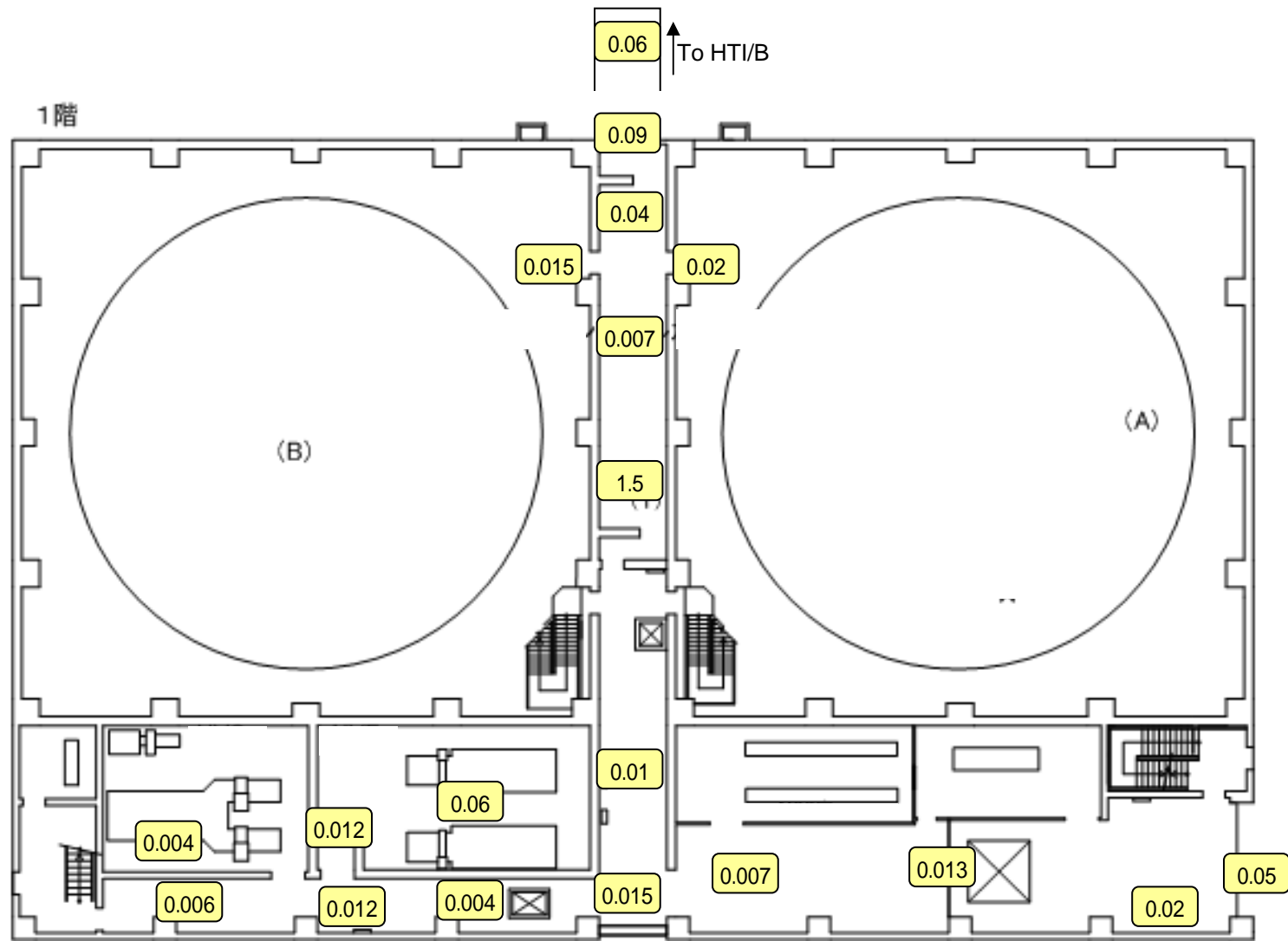

Unit: mSv/h

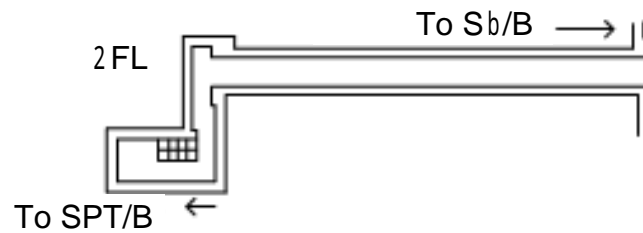

1FL, Suppression Pool Water Surge Tank Bldg

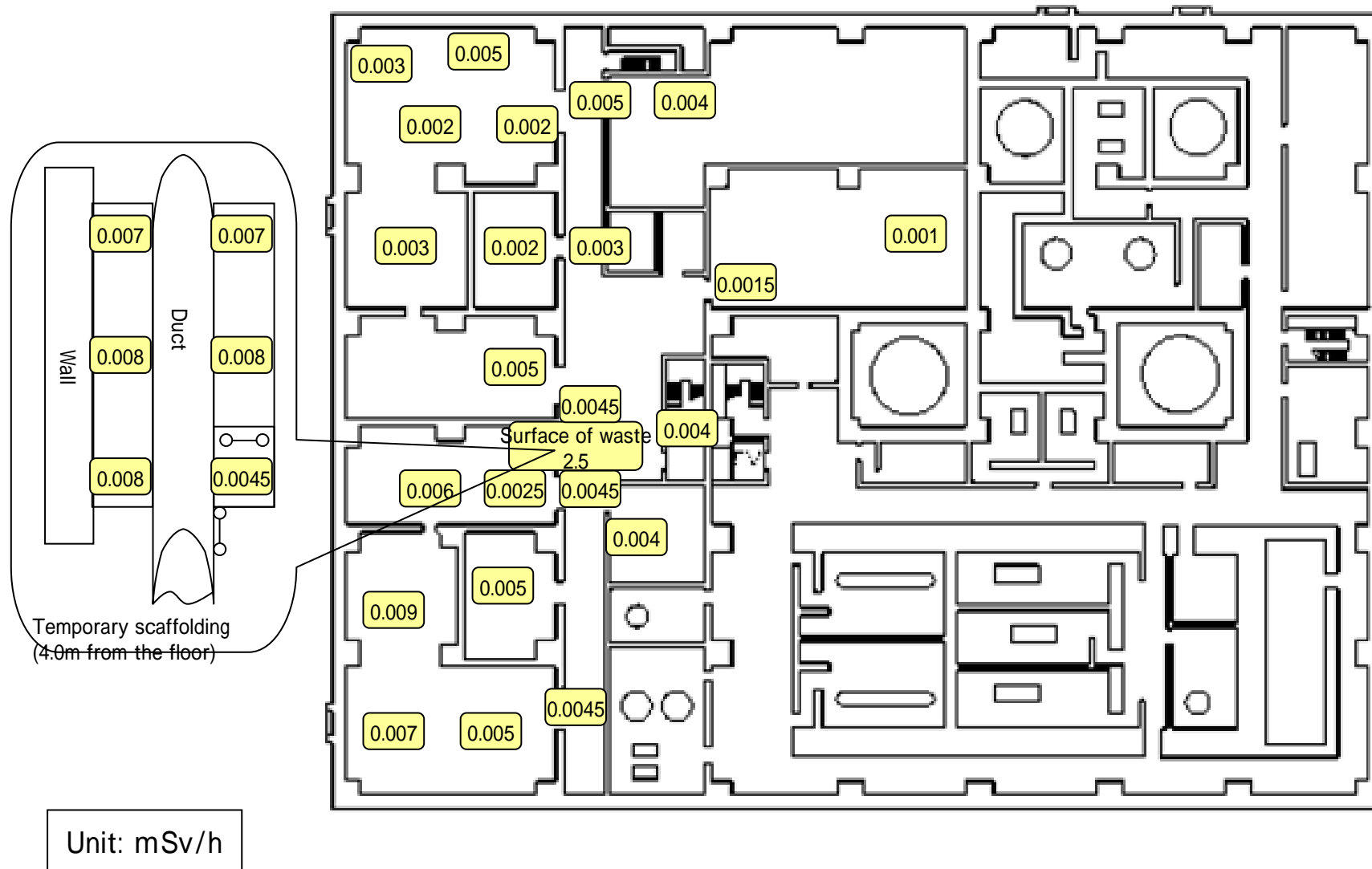

B1, Operation Auxiliary Shared Facility

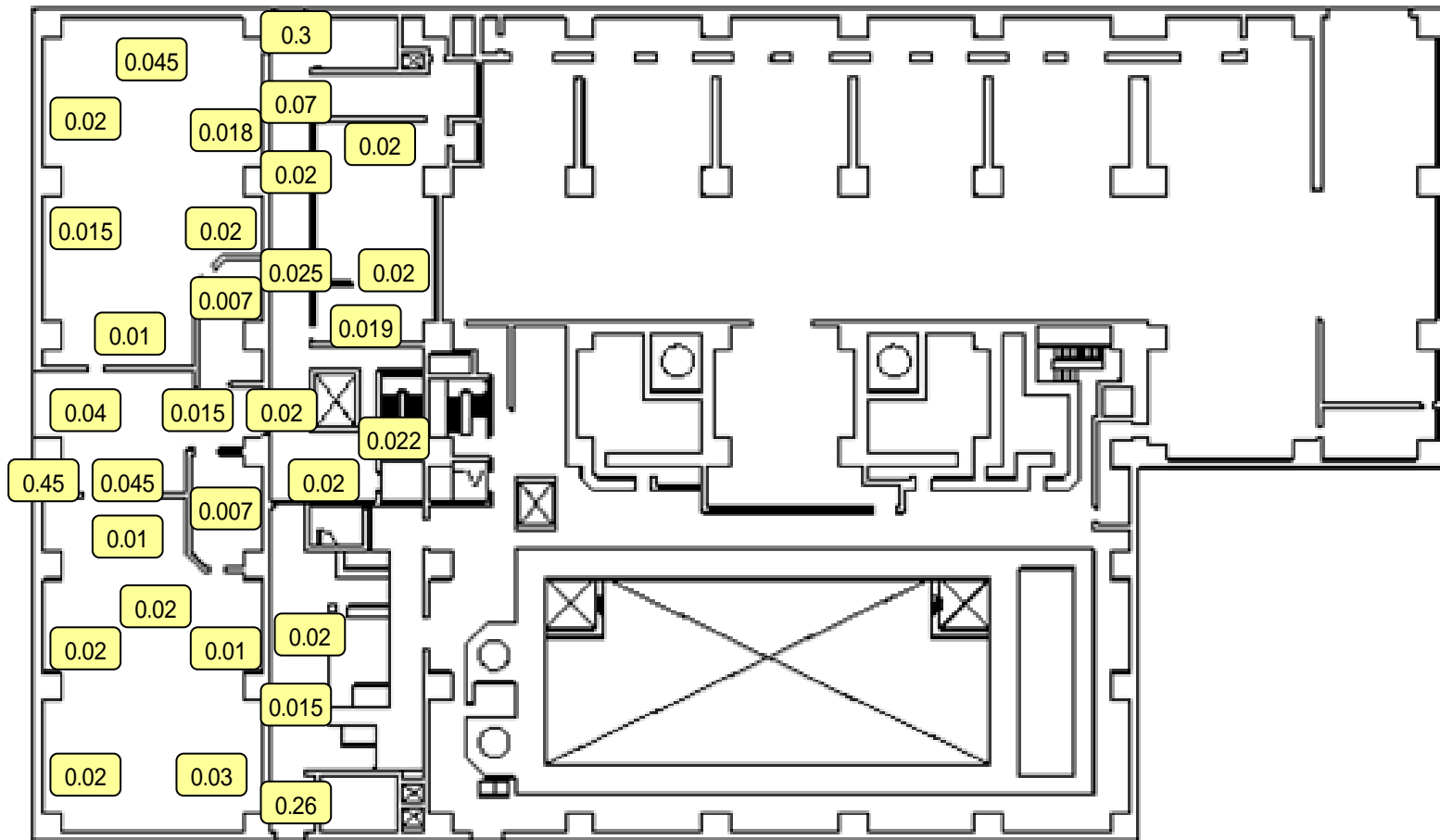

Unit: mSv/h

1FL, Operation Auxiliary Shared Facility

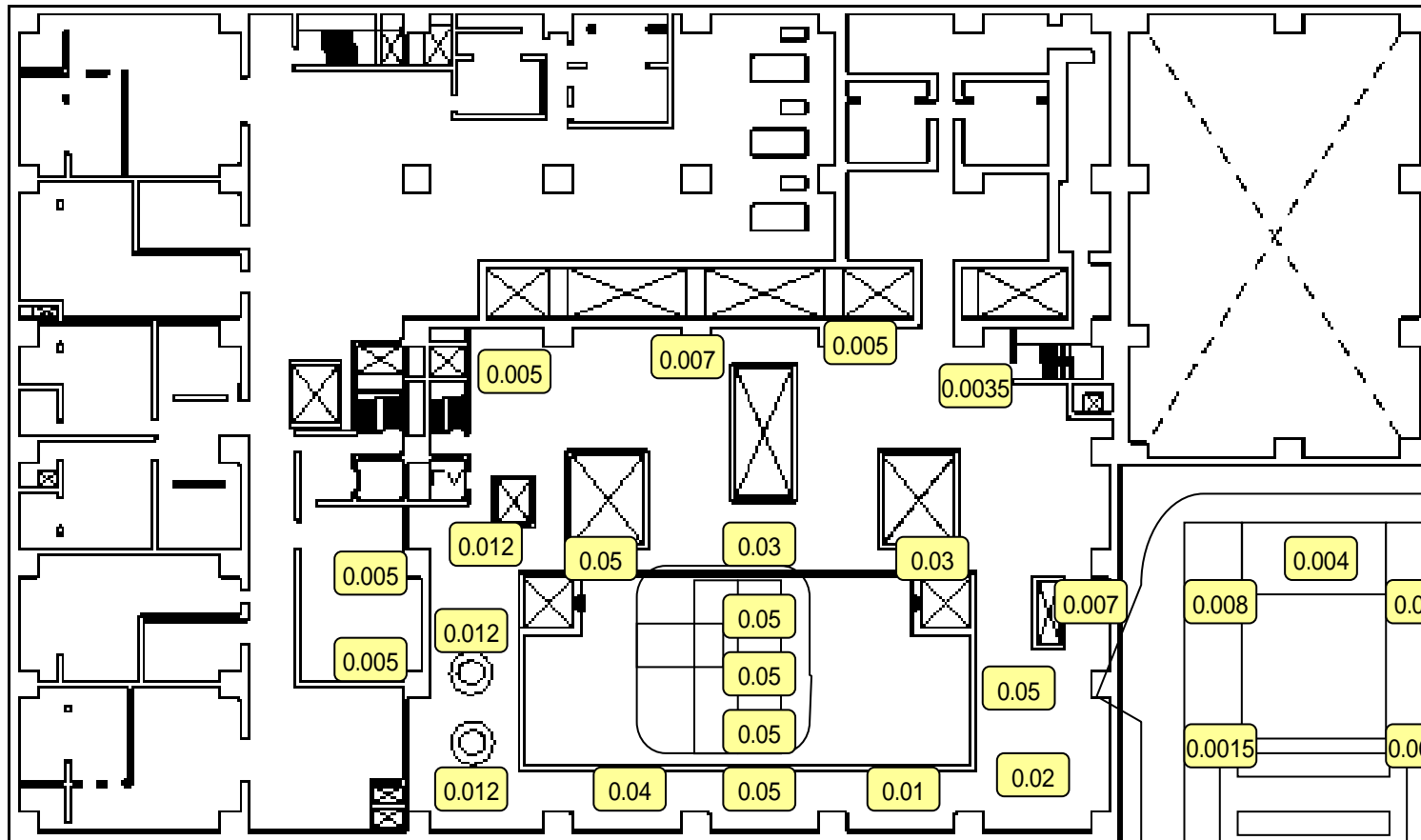

Unit: mSv/h

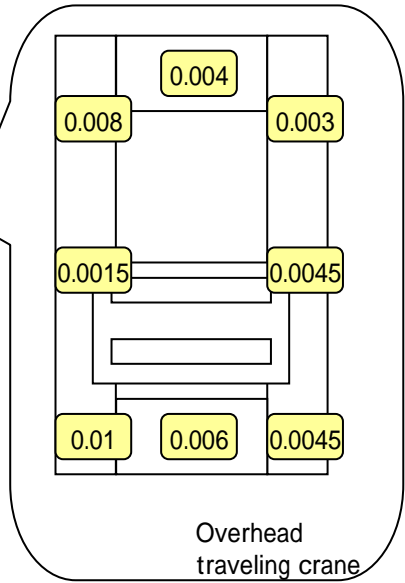

3FL, Operation Auxiliary Shared Facility