

Reactor pressure behavior during high pressure water injection at Unit-3

1. Summary

The earlier report*¹, submitted to the Nuclear Industry and Safety Agency in May 2011, specified an example of operating conditions of the high pressure coolant injection system (HPCI) of Unit-3, by which the plant behavior observed could be explained. It stated, concerning the evaluation of Unit-3 plant conditions: “During the period when the HPCI was in operation the pressures were in a decreasing trend. Should steam leakage to the outside of PCV be assumed through the HPCI steam piping the analysis could roughly reproduce the changes of reactor pressure and PCV pressure.”

In the subsequent investigations, it turned out that the HPCI had been continuing its operation while controlling its flow rate. A new assumption was made in the analysis, in which part of water from the condensate storage tank (CST) had been carried to the suppression chamber (S/C) via the minimum flow line in order to maintain the certain amount of HPCI flow rate. The results could explain the pressure changes of the reactor and the PCV and there were publically released on July 28th, 2011.

The following three pieces of information were newly known, as reported in “First-hand responses to the accident at the Fukushima Daiichi Nuclear Power Station (in Japanese) which was made public on December 22nd, 2011.

- The minimum flow line had been fully closed, due to concern about the S/C water level increase.
- The HPCI flow rate had been controlled by sending part of the water injected for the reactor to the test line.
- The PCV had been cooled by spray.

Based on these new findings, the HPCI operating conditions were reviewed and the results were reported on December 22nd, 2011 to the Nuclear Industry and Safety Agency*².

The HPCI operating conditions assumed in July 2011 differed from the actual conditions, but the following two key features remained unchanged: (1) steam had been continuously extracted from the reactor through the HPCI piping and (2) the PCV pressure had been suppressed by feeding water to the S/C from the external water source (that is, the CST).

As a consequence, the results in the December 2011 analysis and in the new analysis this

*¹ Analysis and evaluation of impacts of the operation records at the Fukushima Daiichi Nuclear Power Station when the Tohoku–Chihou-Taiheiyou-Okai Earthquake occurred, May 23rd, 2011 (in Japanese).

*² Investigation results of the accident and accident progression at the Fukushima Daiichi Nuclear Power Station (in Japanese).

time provide similar outputs to those provided in July 2011. It should be noted that there is no influence on the analysis of core conditions, since the reactor water level was maintained anyway while the HPCI was in operation.

2. Situations and maneuvering on site

- ✓ Situations on site
 - If a large amount of steam had been leaking through the HPCI steam piping to outside the PCV, the atmosphere at high temperatures with high humidity would have filled the inside of the reactor building including the HPCI cell and would have prevented human access. Nevertheless, there were operators, who entered the reactor core isolation cooling (RCIC) cell via the HPCI cell on March 13th in order to attempt the RCIC restart after the HPCI had shut down.
- ✓ HPCI maneuvering
 - Once the HPCI started up, its flow rate was being controlled by use of the test line, while the reactor water level was being monitored, in order to avoid repeating the HPCI start-up and shutdown due to “low reactor water level” and “high reactor water level”^{*3}. The minimum flow line was fully closed, due to concern about the S/C water level increase (Figure 1).
 - At that time, the HPCI was using the CST as its water source for water injection to the reactor.
- ✓ PCV spray maneuvering
 - The PCV spray was underway in the sequence shown in Table 1, for the purposes of lowering the PCV pressure and temperature.

Table 1 Chronological events of PCV spray maneuvering

Date	Time	Events
March 12 th	12:06	S/C spray by DDFP started
March 13 th	03:05	S/C spray by DDFP stopped
	05:08	S/C spray by DDFP started
	07:39	D/W spray by DDFP started
	07:43	S/C spray by DDFP stopped
	08:40~09:10	D/W spray by DDFP stopped

^{*3} The operating procedures prescribe continuous HPCI operation should not be impeded by repeating start-up and shutdown due to “low reactor water level (L-2)” and “high reactor water level (L-8).”

3. Possibilities of HPCI pipe break from the design viewpoint

In the May 2011 analysis, an assumption was made, as a sample case to simulate the pressure changes observed for the reactor and the PCV, that steam had leaked outside the PCV via the HPCI piping [see footnote *1]. But it is quite unlikely from the design viewpoint, as reported in July 2011, that the HPCI piping broke and discharged a large amount of steam through there [see footnote *2]. The reasons were as follows.

- The reactor water level was maintained during the HPCI operation. This means that water injection to the reactor was ongoing, while steam generated in the reactor was transferred to the HPCI.
- If the HPCI piping broke and the steam was discharged outside the PCV, the HPCI isolation signal should be issued due to “HPCI steam piping break (high steam flow rate).” In addition, temperature detectors installed around the HPCI steam piping such as in the HPCI turbine/pump cell, steam supply line penetration cell, etc., would issue the isolation signal due to “high atmospheric temperature.” Therefore, the HPCI would not work or shut down. This is not consistent with the situation that the reactor water level could be maintained.

4. Cause of plant behaviors such as the reactor pressure decrease

MAAP results (reactor water level and pressure changes) are shown in Figure 3 and Figure 4, in which the HPCI flow rate was controlled and the maneuvering sequence in Table 1 were considered. The flow rates for water injection of the RCIC and HPCI were adjusted in the analysis so that the measured reactor water level could be reproduced.

- In the design scenario, the reactor pressure decreases when the HPCI starts injection and the steam used for injection by the HPCI is condensed in the S/C, causing both the S/C temperature and the PCV pressure to increase.
- The observed reactor pressure actually decreased due to the continued HPCI operation. In the meantime, the HPCI flow rate was being adjusted, using the test line, in order to avoid unnecessary HPCI shutdown due to “high reactor water level (L-8).” The PCV pressure and temperature are considered to have been prevented from increasing by use of the PCV spray.
- If the amount of water injection was increased immediately after the HPCI start-up and decreased once the reactor water level had increased, the reactor pressure decrease would temporarily slow down immediately after the water injection amount was decreased, because of the HPCI turbine flow decrease and the steam production increase.

5. Conclusion

It is considered, based on the fact that operators entered the HPCI cell after the HPCI shutdown and from the design viewpoint, that the reactor pressure decrease was not caused by the HPCI pipe break, but was the result of the HPCI continuing to operation. This result is consistent with the reports on July 28th [see footnote *1] and on December 22nd, 2011 [see footnote *2].

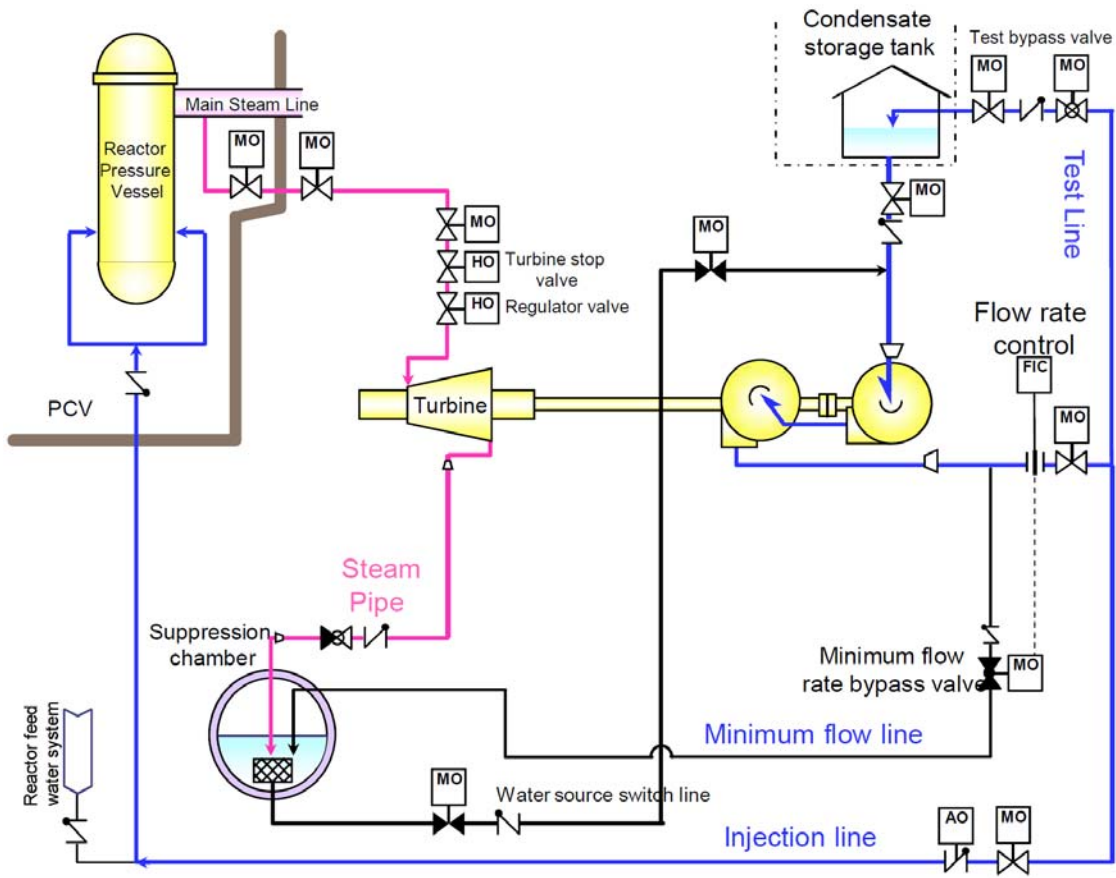

Figure 1 Schematic diagram of the HPCI

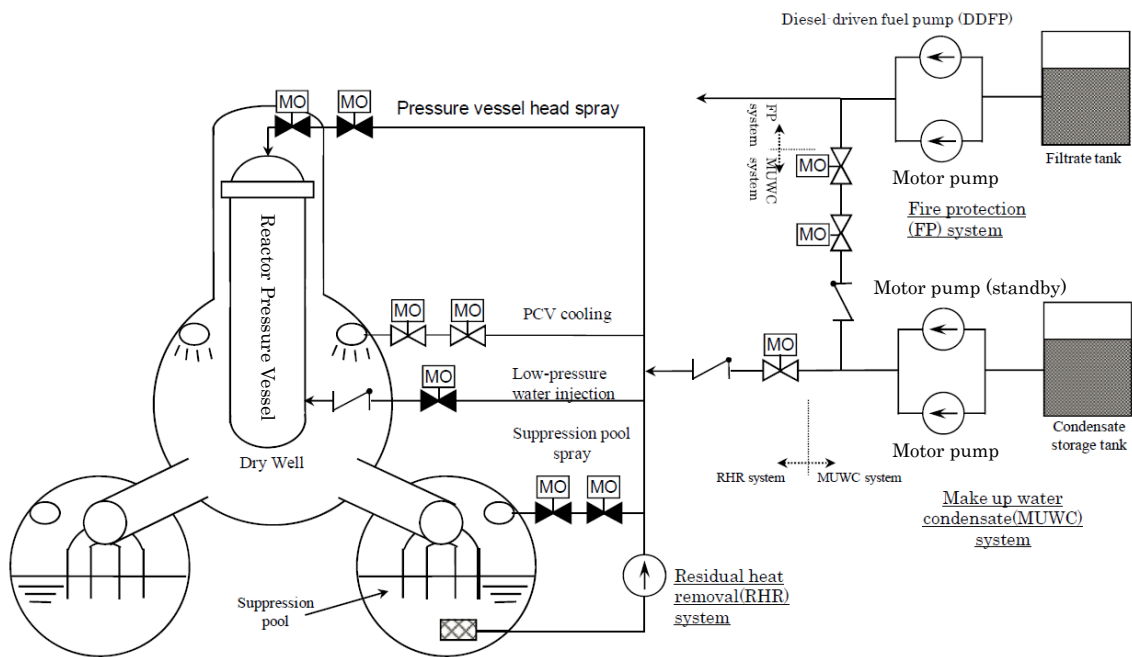

Figure 2 Schematic diagram of alternative PCV spray system of Unit-3

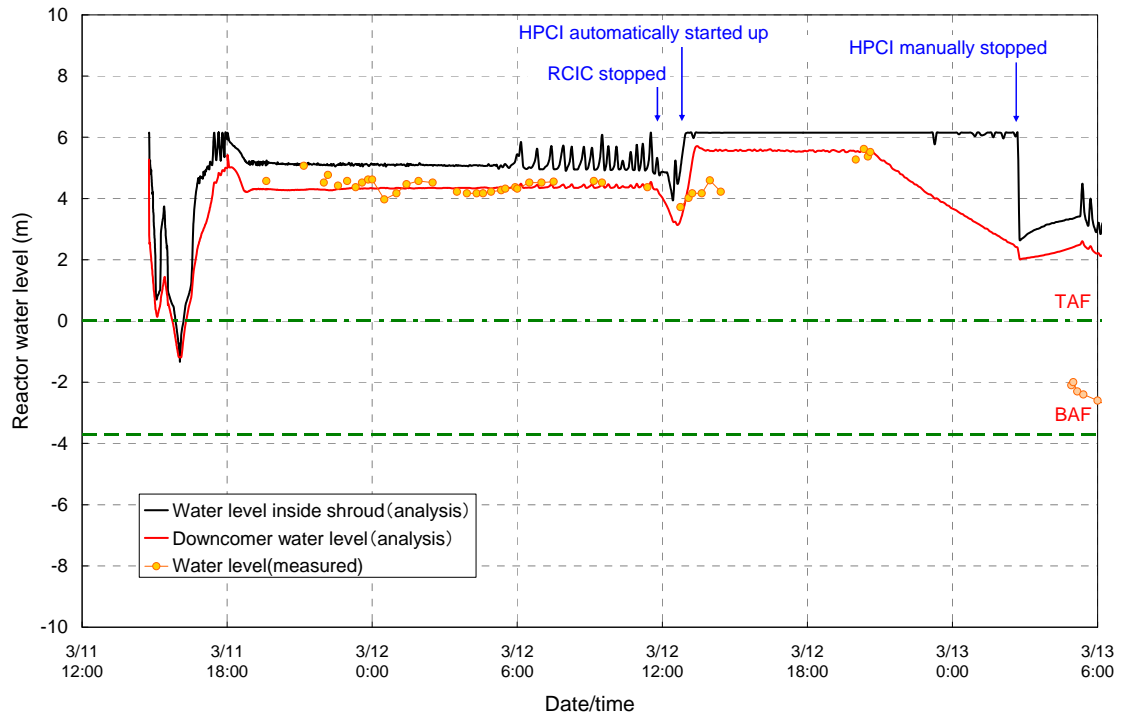

Figure 3 Reactor water level changes of Unit-3 (MAAP analysis reported in March 2012)

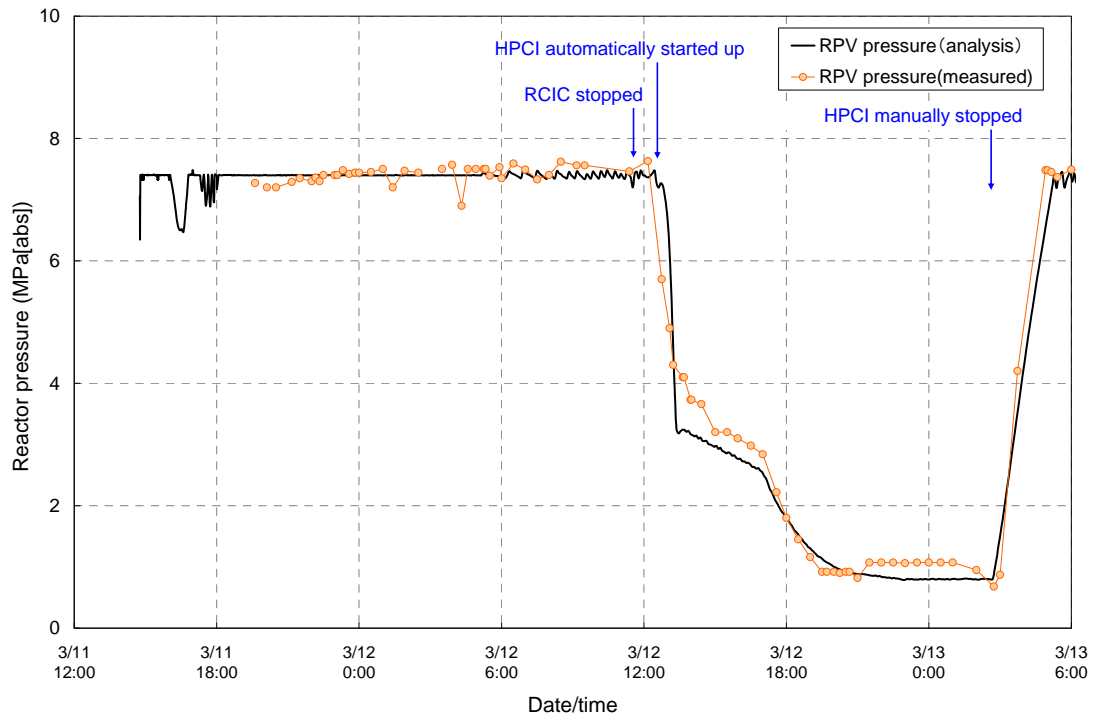

Figure 4 Reactor pressure changes of Unit-3 (MAAP analysis reported in March 2012)